

OLT 52 B

Parts Manual



The information, specifications, and illustrations in this manual are on the basis of information available at the time it was written. The specifications, torque values, pressures of operation, measurements, adjustments, illustrations, and other items can change at any time. These changes can affect the service of the given product.

For the complete and most current information, contact:

Hogg & Davis, Inc
P.O. Box 405 / 3800 Eagle Loop
Odell, OR 97044-0405
541-354-1001
541-354-1080 Fax

**For most recent manual
version please visit:
www.hoggdavis.com**

OLT 52 B
Overhead Line Bullwheel Tensioner

Table of Contents

Table of Contents	- 2 -
Product Warnings.....	- 3 -
General Specifications	- 4 -
LOADING INSTRUCTIONS	- 6 -
Setup on the Job.....	- 7 -
Setup of the unit.....	- 7 -
Position of unit.....	- 7 -
Jack Stands / Outriggers.....	- 7 -
Tie Down/ Brake/ Chock	- 7 -
Load the Bull wheels	- 8 -
Load the Bull wheels (continued)	- 8 -
TENSIONING PROCEDURE.....	- 8 -
HYDRAULIC REWIND (OPTION).....	- 9 -
LUBRICATION AND MAINTENANCE	- 10 -
Items to be inspected.....	- 10 -
Lubrication Schedule	- 10 -
Drawbar inspection	- 11 -
15-15 Warranty	- 12 -
Parts and other manufacturer manuals	- 13 -



"Rugged Dependability."

© COPYRIGHT 2013 HOGG & DAVIS, INC



OLT 52 B Overhead Line Bullwheel Tensioner

Product Warnings

⚠ DANGER

AN UNTRAINED OPERATOR
SUBJECTS HIMSELF AND
OTHERS TO

DEATH OR SERIOUS INJURY

YOU MUST NOT OPERATE
THIS MACHINE UNLESS

- You have been trained in the safe operation of this machine.
- You have read, understand and follow the safety and operating recommendations contained in the machine manufacturer's manuals, your employer's work rules and applicable government regulations.
- You are sure the machine is operating properly and has been inspected and maintained in accordance with the manufacturer's manuals.
- You are sure that all safety signs, guards and other safety features are in place and in proper condition.

© H&D, Inc. 1999

⚠ DANGER



REACHING INTO REEL AREA
OR CONTACTING TURNING
REEL OR MOVING LINE
DURING OPERATION MAY
RESULT IN

DEATH OR SERIOUS INJURY

© H&D, Inc. 1999

⚡ DANGER

ELECTROCUTION HAZARD EXISTS
WHEN PULLING LINE OR
CONDUCTOR IS NEAR ENERGIZED
LINES. MAKE SURE MACHINE IS
PROPERLY GROUNDED AND
OPERATOR IS PROPERLY
PROTECTED.

© H&D, Inc. 1999

⚠ DANGER



JACKSTAND AND OUTRIGGER
CONTACT WILL CAUSE SERIOUS
CRUSHING INJURY.

STAND CLEAR

⚠ WARNING



Escaping fluid under pressure
can penetrate skin causing
serious injury.

Relieve pressure before disconnecting
hydraulic lines. Keep away from leaks
and pin holes. Use a piece of cardboard
or paper to search for leaks. Do
not use your hand.

Fluid injected into skin must be
surgically removed within a few hours
by a doctor familiar with this type
injury or gangrene will result.

© H&D, Inc. 1999

These warning labels and others like it are placed in critical areas of the machine. The warnings are to be read and fully understood prior to operation of the unit.

OLT 52 B

Overhead Line Bullwheel Tensioner

General Specifications

This unit is designed to tension overhead cable/conductor at a constant.

- 52 inch 5 Groove Bull wheels
- 1.5 inch Groove
- 5000 lbs Maximum Tension
- 90" X 56" Maximum Reel Diameter
- 12,000 lb Maximum Reel Capacity
- Manual Jack stands (2) Rear – (1) Tongue
- Manual Rewind (Standard)
- Hydraulic Rewind (optional)

OLT 52 B

Overhead Line Bullwheel Tensioner

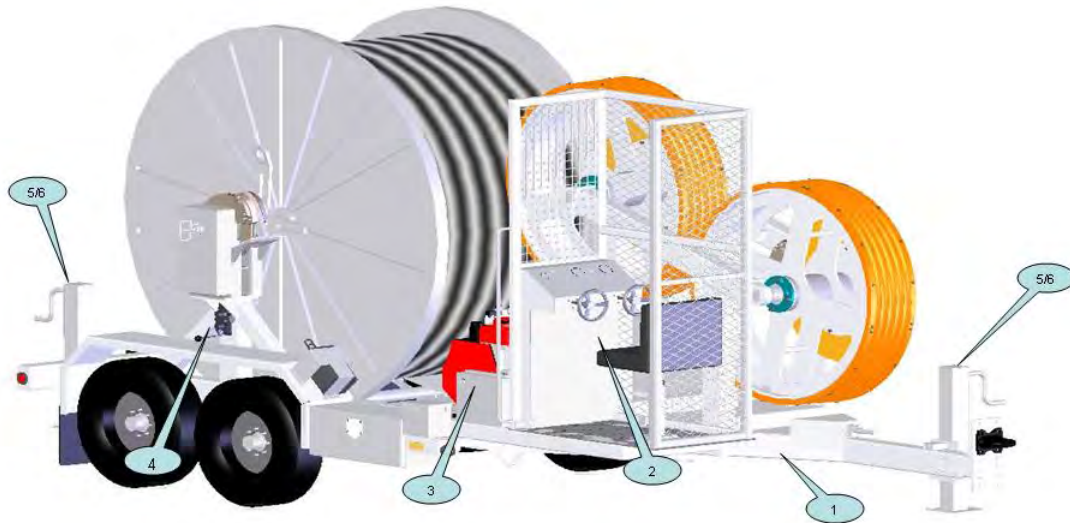

Operating Instructions

All persons operating this machine must read and understand this manual as well as the operating, danger, and warning decals placed on the machine. Failure to read and understand these items subjects the operator and others to **DEATH or SERIOUS INJURY.**

Operators shall make themselves familiar with the placement of the following operating and safety features of the machine.

- Grounding Lugs and their placement on Machine (1)
- Bull wheel Pressure / Tension Control (2)
- Engine Controls (optional) (3)
- Hydraulic / Manual Rewind System (optional) (4)
- Manual Jack stands (standard) (5)
- Hydraulic Jack stands (optional) (6)

OLT 52 B
Overhead Line Bullwheel Tensioner

LOADING INSTRUCTIONS

ALL REELS TO BE LOADED FOR PAYOUT UNDERNEATH THE REEL.
PAYOUT OF CONDUCTOR OVER THE TOP OF THE REEL MAY
CAUSE DAMAGE TO THE CONDUCTOR.

1. Position trailer so that forklift or crane can be easily positioned.
2. Position reel drive pin assembly so that the lifting eye and removable pin are in the top position and apply brake.
3. Remove retaining pin from both the reel drive pin assembly and the dumb end of the mandrel shaft pocket.
4. Remove entire shaft and drive pin assembly by lifting up.
5. Remove Nylatron bearing from dumb end of mandrel shaft.
6. Remove locking collar / lifting assembly and centering cone.
7. Insert mandrel shaft in the reel all the way to the drive pin assembly, being careful to insert the pins completely.
8. Install centering cone (if needed) and locking collar / lifting assembly. Be sure to set reel tight against drive pin assembly.
9. Replace Nylatron bearing onto dumb end of mandrel shaft.
10. Lift reel with forklift or crane making sure that the drive pin assembly has the lifting eye on top for proper fit.

OLT 52 B Overhead Line Bullwheel Tensioner

11. Insert reel into the stand by indexing drive pin assembly from above and lower into place.
12. Insert retaining pins into both the drive pin assembly and the dumb end of the shaft pocket.

Setup on the Job

Setup of the unit

Position of unit

Position the trailer with the centerline of the trailers inline with the pull. Place the unit at a minimum of two times the height of the first block.



Jack Stands / Outriggers

Actuate the rear outriggers to stabilize the trailer. Attempt to level the trailer as much as possible. The outriggers have the ability to raise the tires from the ground, but as a rule they should be used to stabilize the load across all contact points on the ground, i.e. Jack stands, tires, front tongue jack stand.

Tie Down/ Brake/ Chock

Chock all wheels and set brakes (if applicable). It should be noted that a fully loaded trailer may exceed the tension desired during the pull. As the pull progresses, the weight of the trailer decreases, therefore proper securing procedures should be followed during operation. This unit is equipped with tie – down eyes for staking to the ground and it is recommended

OLT 52 B Overhead Line Bullwheel Tensioner

that the unit stay secured to the tow vehicle whenever possible.

Load the Bull wheels

Reeve conductor through the captive fairlead assembly and under and around the first groove in the lower Bull wheel. The conductor will be reeved around the entire Bull wheel assemblies and exits towards the first block off the upper Bull wheel groove.

Load the Bull wheels (continued)

It is less difficult if rope were to be reeved through the bull wheels instead of conductor. Placed the pulling rope in the bull wheels and

Slowly allow the rope to be pulled, thus reeveing the conductor under power. When loading the bull wheels in this manner SLOW is the maximum speed.

TENSIONING PROCEDURE

Adjust reel brake to provide tail tension to conductor.

***PROPER ADJUSTMENT OF TAIL TENSION IS A CRITICAL PART OF THE CONDUCTOR TENSIONING PROCESS.** Too much tension can cause under wraps in the conductor reel and too little tension can produce slippage of the conductor across the Bull wheels and possible "groove hopping" during the pull.

Refer to the performance chart for proper hydraulic pressure as it directly relates to conductor tension. ***This chart is located on the control panel of the unit.***

Turn in Bull wheel actuator to approx 30 lbs above desired tension. As pull begins, turn actuator out slowly until Bull wheels

OLT 52 B Overhead Line Bullwheel Tensioner

begin to payout. As pull progresses, it may be necessary to adjust Bull wheel tension as needed. Also during the pull process it will be necessary to adjust reel payout tension as the reel empties.

As pull comes to an end, increase Bull wheel pressure to hold conductor at desired sag. *Safety off the conductor to the rear of trailer or other stationary device before leaving unit.*

BULLWHEEL BRAKES ARE NOT A PROPER HOLDING DEVICE.

IF MACHINE IS TO BE USED FOR FIBRE OPTIC INSTALLATION, REFER TO THE CABLE MANUFACTURER FOR PROPER TENSIONING TECHNIQUES. FAILURE TO CONSULT MANUFACTURER MAY DAMAGE CABLE AND VOID WARRANTY.

HYDRAULIC REWIND (OPTION)

If the unit is equipped with a hydraulic rewind, it has the capabilities to rewind the unused portion of conductor that was cut loose. It is not intended as a pullback or sag tensioning device and may not be used as such.

After conductor has been cut, release Bull wheel pressure and reel carrier pressure completely. Start engine and place lever in to TAKE UP position. After tails have been rewound, place lever to NEUTRAL and shut off engine.



"Rugged Dependability."

© COPYRIGHT 2013 HOGG & DAVIS, INC



OLT 52 B
Overhead Line Bullwheel Tensioner

LUBRICATION AND MAINTENANCE

This unit has no set PM schedule beyond that of the engine manufacturers suggested maintenance schedule. This unit should be visually inspected prior to each use while repairing any and all discrepancies prior to use.

Items to be inspected prior to use are:

- Pintle eye (excessive wear)
- Safety Chains (wear / damage)
- All welds and seams
- Loose or missing fasteners (bolts, nuts, set screws)
- Loose or leaking hydraulic hoses
- Damages or worn hydraulic hoses
- Brake calipers (loose fittings, hoses, worn linings)
- Brake Pads
- Urethane Bull wheel linings
- Brake rotors
- Tires and trailer brakes
- Engine and hydraulic system fluid levels.

Lubrication Schedule

- Bull wheel Bearings (daily before each use)
- Axle Bearings (as needed)
- Engine oil as per manufacturers recommendation
- Retriever shaft (weekly)



"Rugged Dependability."

© COPYRIGHT 2013 HOGG & DAVIS, INC



OLT 52 B **Overhead Line Bullwheel Tensioner**

Drawbar inspection

- Regularly inspect the drawbar for wear and damage. If wear exceeds 1/8", replace the drawbar eye.
- Check all drawbar mounting fasteners for proper torque.
- Do not modify or add to the product.
- Do not weld on this product without written permission from the factory.
- Be sure the drawbar size is compatible with the coupling device on the tow vehicle.
- Do not damage the coupling components. Be particularly careful during coupling and uncoupling.
- Inspect the coupling device on the tow vehicle for proper locking prior to use.
- Consult OSHA and DOT regulations and American Trucking Association guidelines for complete operating procedures.



"Rugged Dependability."

© COPYRIGHT 2013 HOGG & DAVIS, INC



OLT 52 B
Overhead Line Bullwheel Tensioner

15-15 Warranty

Hogg and Davis, Inc. warrants its trailers against Defects in material or workmanship for period of 15 months from the date of shipment from Hogg and Davis, Inc. (see General Conditions & Exceptions). Hogg and Davis, Inc. will replace, free of charge, F.O.B. Hogg and Davis, Inc. factory, such parts or parts thereof, that in their judgement have proven defective. Additionally, Hogg and Davis, Inc. will pay reasonable and customary labor charges when defective part is replaced, installed or repaired by a fully authorized Hogg and Davis, Inc. trailer dealer at his facility.

Warranty credit will be issued only upon receipt and inspection of defective parts of at the Hogg and Davis, Inc. factory.

Hogg and Davis, Inc. warrants its trailer main frame assemblies (except pintle eyes or other towing attachments, spindles and axles) against defects in material or workmanship for a period of **15 years** from the date of shipment from Hogg and Davis, Inc. (see General Conditions & Exceptions). Hogg and Davis, Inc. shall replace or repair, in a manner as it shall determine, free of charge, F.O.B. factory, any parts or parts thereof, that in its judgement have proven defective. Additionally, Hogg and Davis, Inc. will pay reasonable and customary labor charges when defective part is replaces, installed or repaired by a fully authorized Hogg and Davis, Inc. trailer dealer at his facility

General Conditions & Exceptions

All warranties, options and representations made herein shall apply only provide such equipment shall not have been subject to misuse, negligence or accident and has been operated in accordance with factory approved procedures. This warranty does not obligate Hogg and Davis, Inc. or its authorized dealers to bear the cost of parts obtained from or labor performed by unauthorized sources. Nor does it obligate Hogg and Davis, Inc. **or its** authorized dealers to bear the cost of transportation of parts or equipment for repair or **replacement purposes**. This warranty is in lieu of any other warranty, expressed **or implied**, or any other obligation or liability on the part of Hogg and Davis, Inc and no persons or entity is authorized to make any representation beyond those stated herein.

Hogg and Davis, Inc. shall not be held liable for consequential damage of any kind. Hogg and Davis, Inc. also reserves the right to make changes and improvements in its products without incurring any obligation to install any such changes or improvements upon its products previously manufactured.

The above warranty shall not be misconstrued to mean warranty of tires, clutch, transmission assemblies or customer requested accessory equipment other than the warranty extended by their respective manufactures to Hogg and Davis, Inc. In addition, friction, drive rollers are warranted only to extent of bonding failure. All warranties, options and representations made herein are applicable to the original end-user of the product and are not sellable or transferable in any manner.



"Rugged Dependability."

© COPYRIGHT 2013 HOGG & DAVIS, INC



OLT 52 B
Overhead Line Bullwheel Tensioner

Parts and other manufacturer manuals

The Following drawings are for part identification only. Please reference the unit V.I.N. number and the corresponding part number when ordering.

The information, specifications, and illustrations in this manual are on the basis of information available at the time it was written. The specifications, torque values, pressures of operation, measurements, adjustments, illustrations, and other items can change at any time. These changes can affect the service of the given product.

For the complete and most current information, contact:

Hogg & Davis, Inc
P.O. Box 405 / 3800 Eagle Loop
Odell, OR 97044-0405
541-354-1001
541-354-1080 Fax
www.hoggdavis.com

Parts Manual

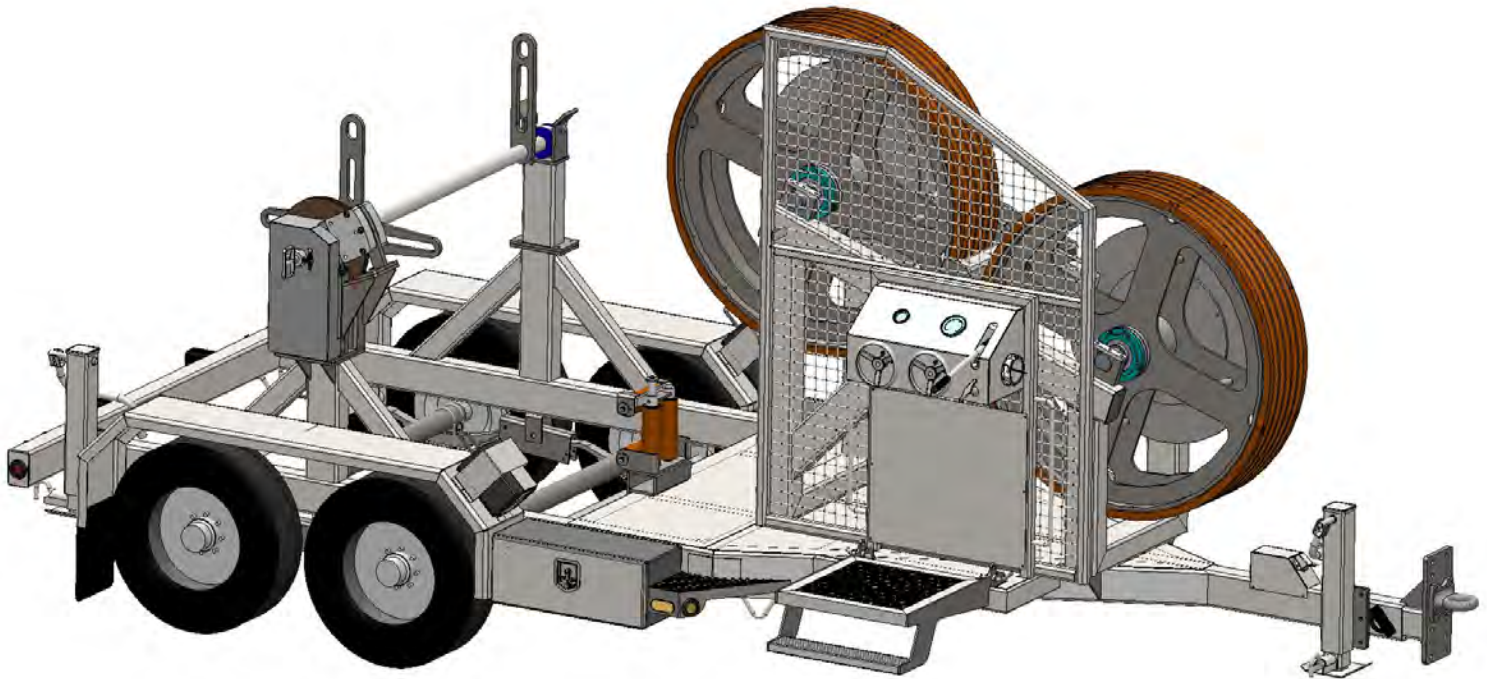

The information, specifications, and illustrations in this manual are on the basis of information available at the time it was written. The specifications, torque values, pressures of operation, measurements, adjustments, illustrations, and other items can change at any time. These changes can affect the service of the given product.

For the complete and most current information, contact:

Hogg & Davis, Inc
P.O. Box 405 / 3800 Eagle Loop
Odell, OR 97044-0405
541-354-1001
541-354-1080 Fax

For most recent manual
version please visit:
www.hoggdavis.com

Table of Contents

<i>Isometric View</i>	1
<i>Curbside View</i>	2
<i>Rear View</i>	3
<i>Reel Shaft Assembly</i>	4
<i>Hydraulic Reel Drive</i>	5
<i>Brake Caliper Assembly</i>	6
<i>Brake Calipers (Old Styles)</i>	7
<i>Bullwheel Assembly</i>	8
<i>Fairlead Assembly</i>	9
<i>Operator Controls</i>	10
<i>HD Brake Cylinder</i>	11
<i>LED Trailer Lights</i>	12
<i>Incandescent Trailer Lights</i>	13
<i>Brake Bleeding Inst.</i>	14
<i>Trailer Specifications</i>	15
<i>Wheel Torque Req.</i>	17
<i>Decal/ Decal Locations</i>	19



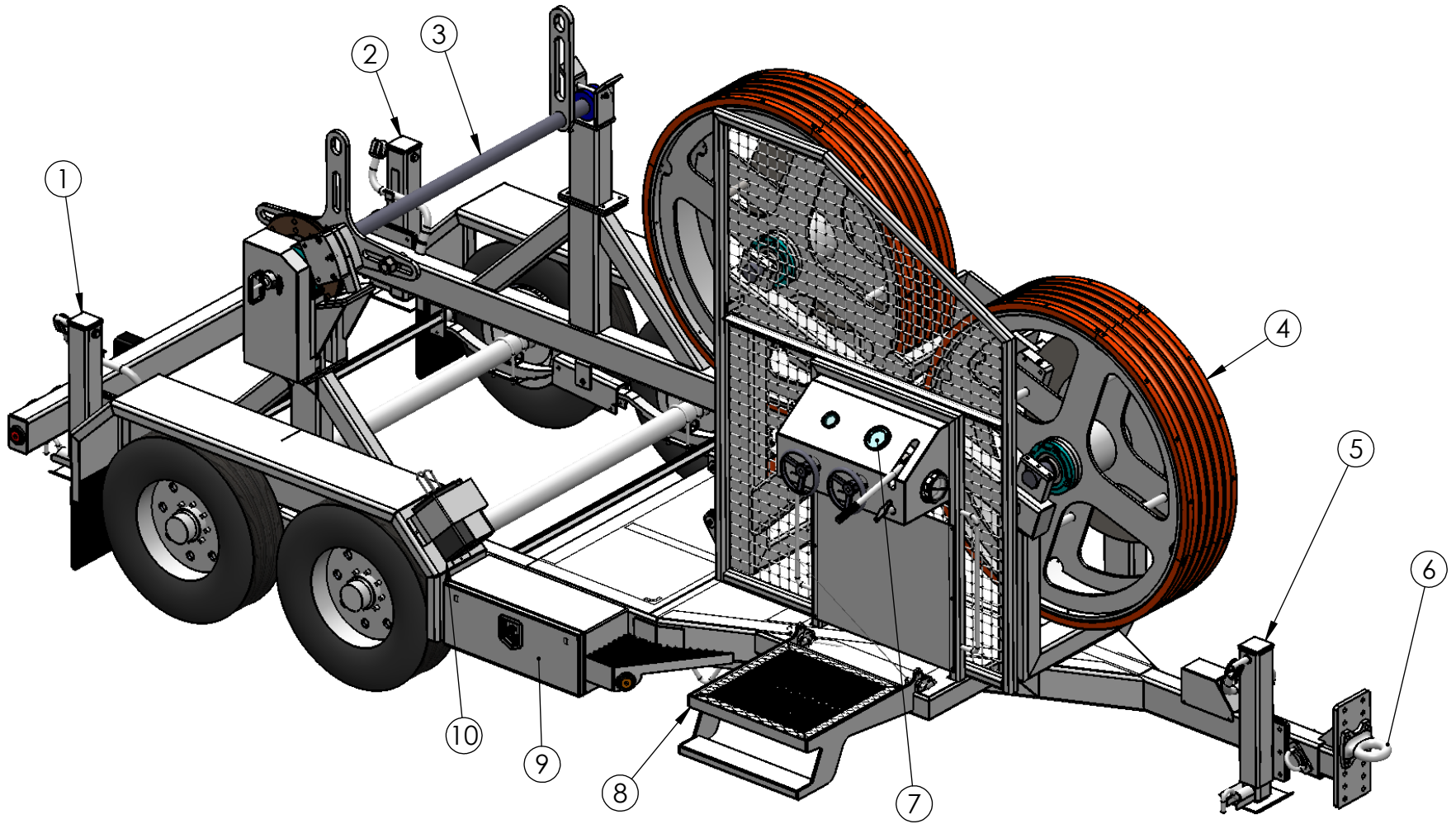

ITEM NO.	PART NUMBER	DESCRIPTION	QTY.
1	J04043	12k Dropleg Jack	1
2	J04042	12k Dropleg Jack	1
3	Reel Assembly	See Reel Shaft Sheet	1
4	Bullwheel	See Bullwheel Sheet	2
5	J04044	12k Dropleg Jack	1
6	E04017	Eye, Pintle	1
7	Controls	See Controls Sheet	1
8	S33001	Operator Step	1
9	D05150	Toolbox Door	2
10	C12005	Wheel Chock	4

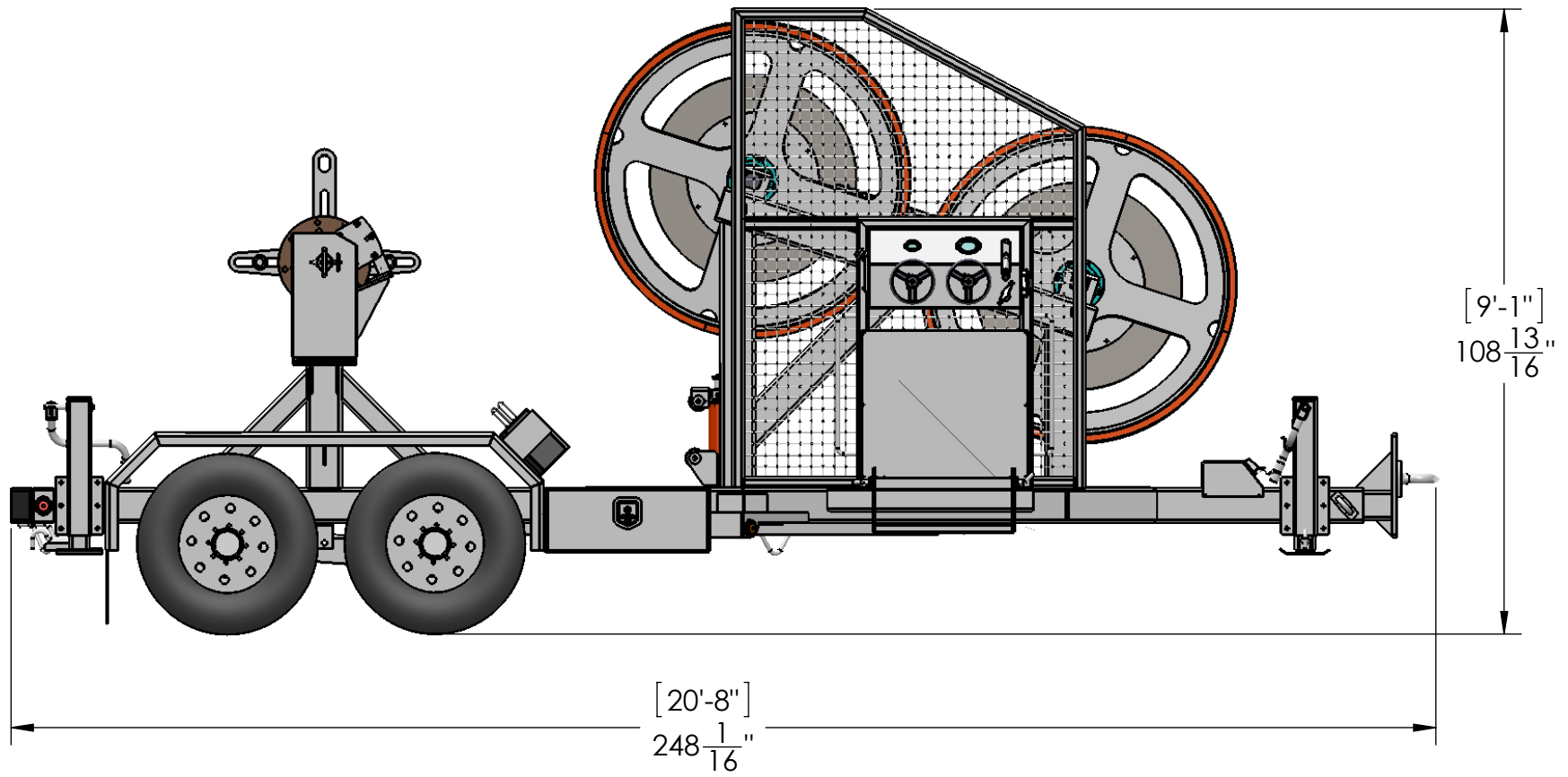

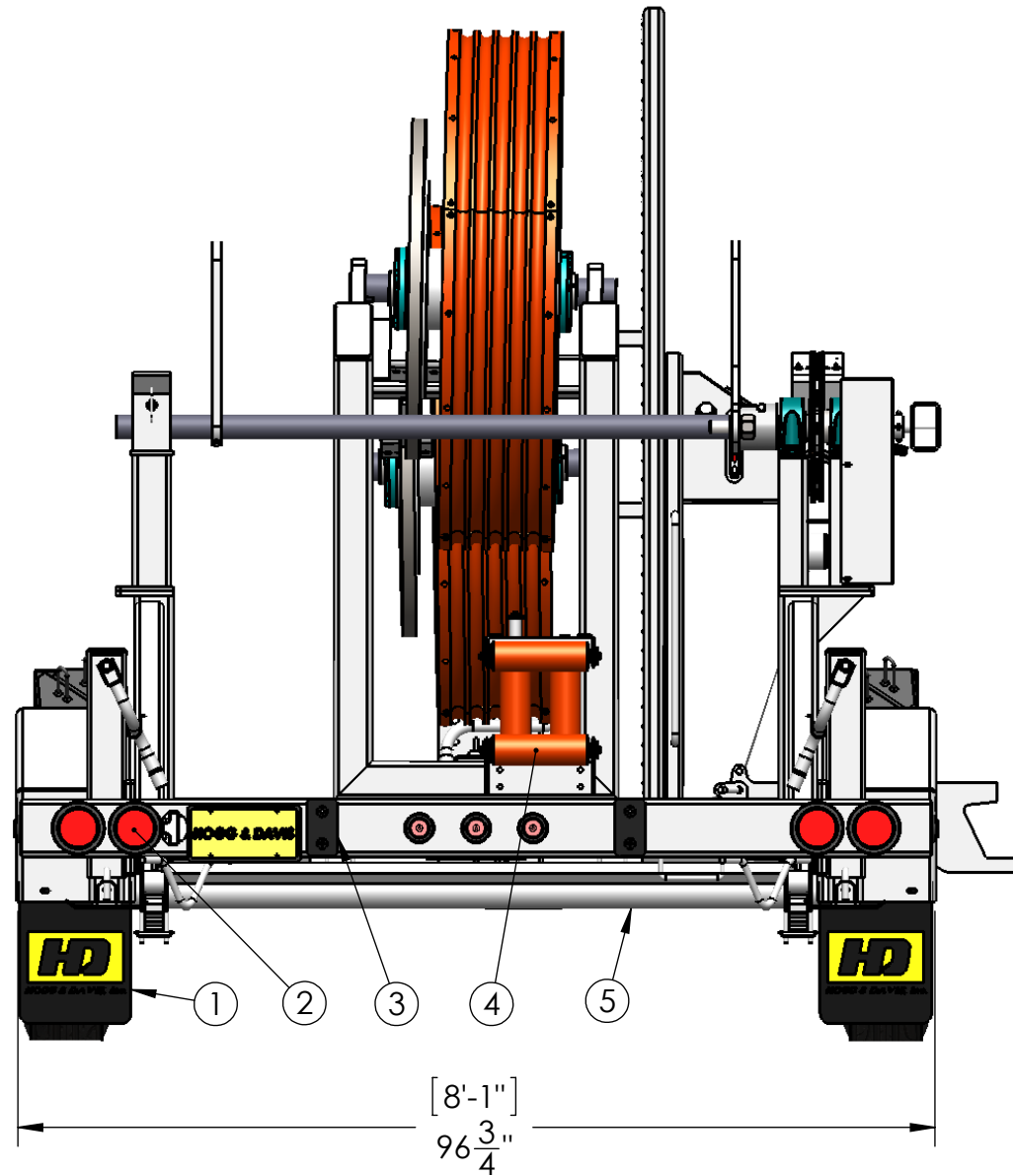

ITEM NO.	PART NUMBER	DESCRIPTION	QTY.
1	F10010	Mud Flap	2
2	Lights	See Lighting Sheets	1
3	B20002	3X6 Bumper	2
4	F09110A	See Fairlead Sheet	1
5	A07101	8k Tandem Axle	1

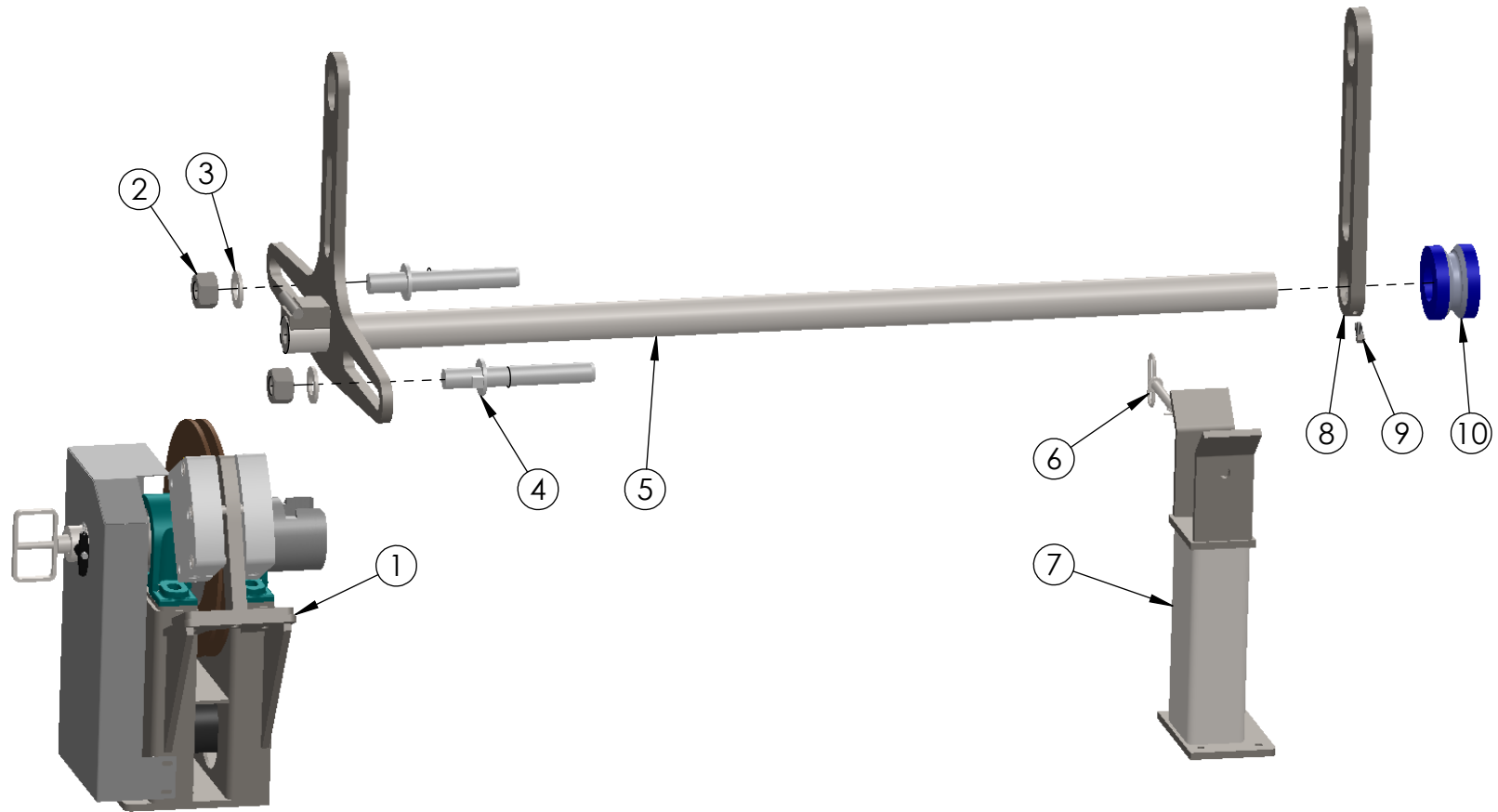

ITEM NO.	PART NUMBER	DESCRIPTION	QTY.
1	OLTPHR	Hydraulic Reel Drive	1
2	N04380	Nut, 1-3/8"-6	2
3	W01595	Washer, Reel Pin	2
4	P06052	Reel Driver Pin	2
5	S43079	Shaft, reel 2-1/2x68-1/2" OLT	1
6	P06056	Pin, 5/8 x 6"	1
7	P14003	Mandrel Post	1
8	E04002	Lifting Eye	1
9	S04475	Screw, Set Sq Head 1/2 x 1	2
10	B07077	Shaft, Bearing- Nylatron	1

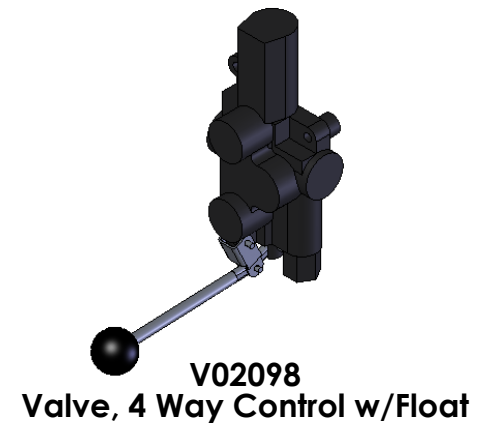
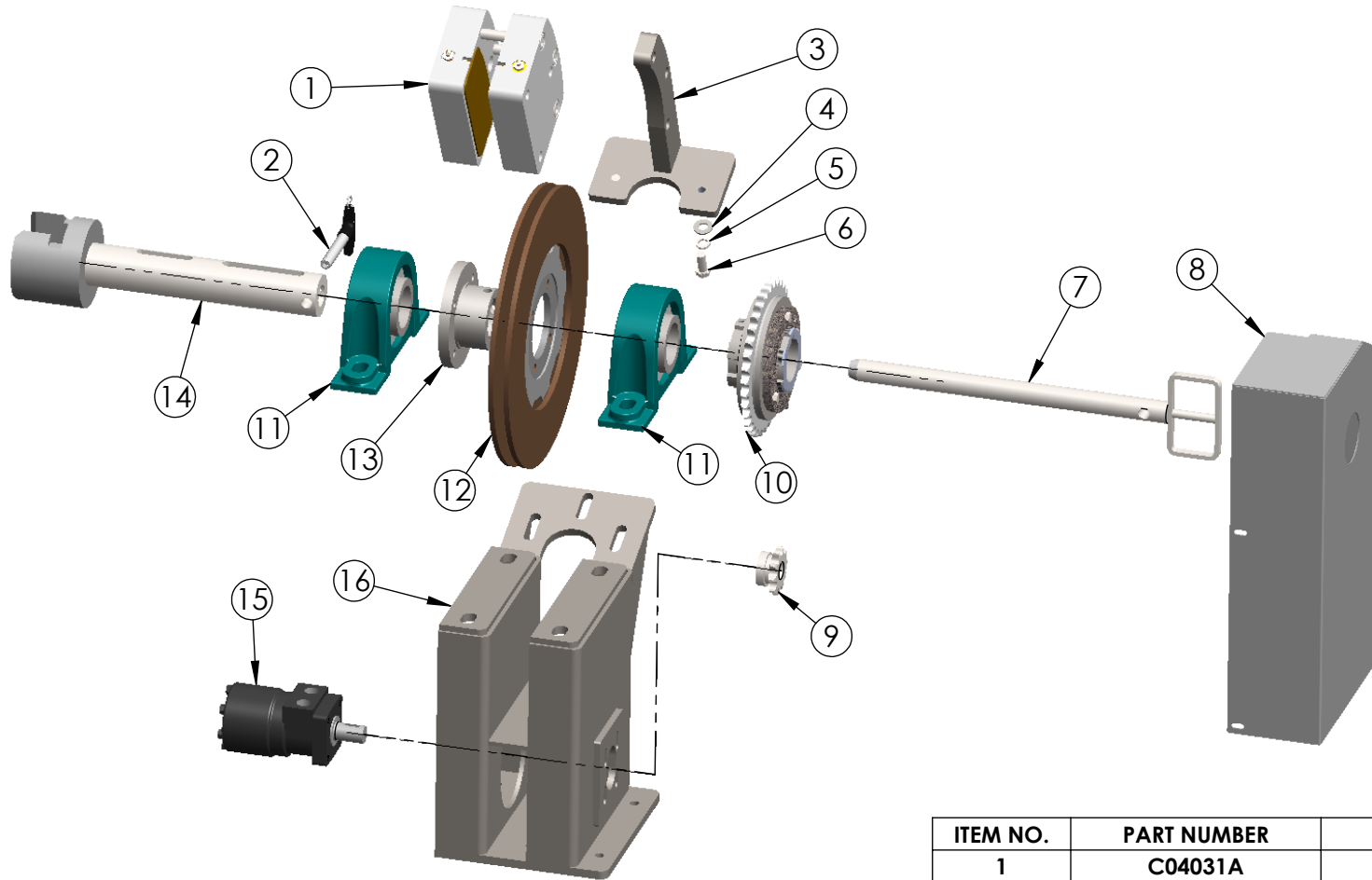

NOTE: Parts 9, 10, 15 & V02098
Are optional for powered reel
retriever

ITEM NO.	PART NUMBER	DESCRIPTION	QTY.
1	C04031A	Caliper, 7" HD brake	1
2	P06003	Pin, Drive Locking	1
3	B15246	Bracket, Caliper mount	1
4	W01005	Washer, Flat SAE 1/2"zinc	3
5	W01565	Washer, Split Lock 1/2"zinc	3
6	B11363	Bolt, Hx Head 1/2"-13 x 1-1/4"	3
7	P06047	Pin, Shaft	1
8	G09027	Guard, Drive	1
9	S29005	Sprocket, Drive	1
10	C18001A	Clutch, Torque Tamer	1
11	B07401	Bearing, 2-7/16" Pillow Block	2
12	D02020	Disc, Vented Brake	1
13	H09106	Hub, brake 2-7/17" shaft	1
14	S43014	Shaft, Bearing	1
15	M08050	Motor, Hydraulic Drive	1
16	F09011	Frame, OLTPHR	1

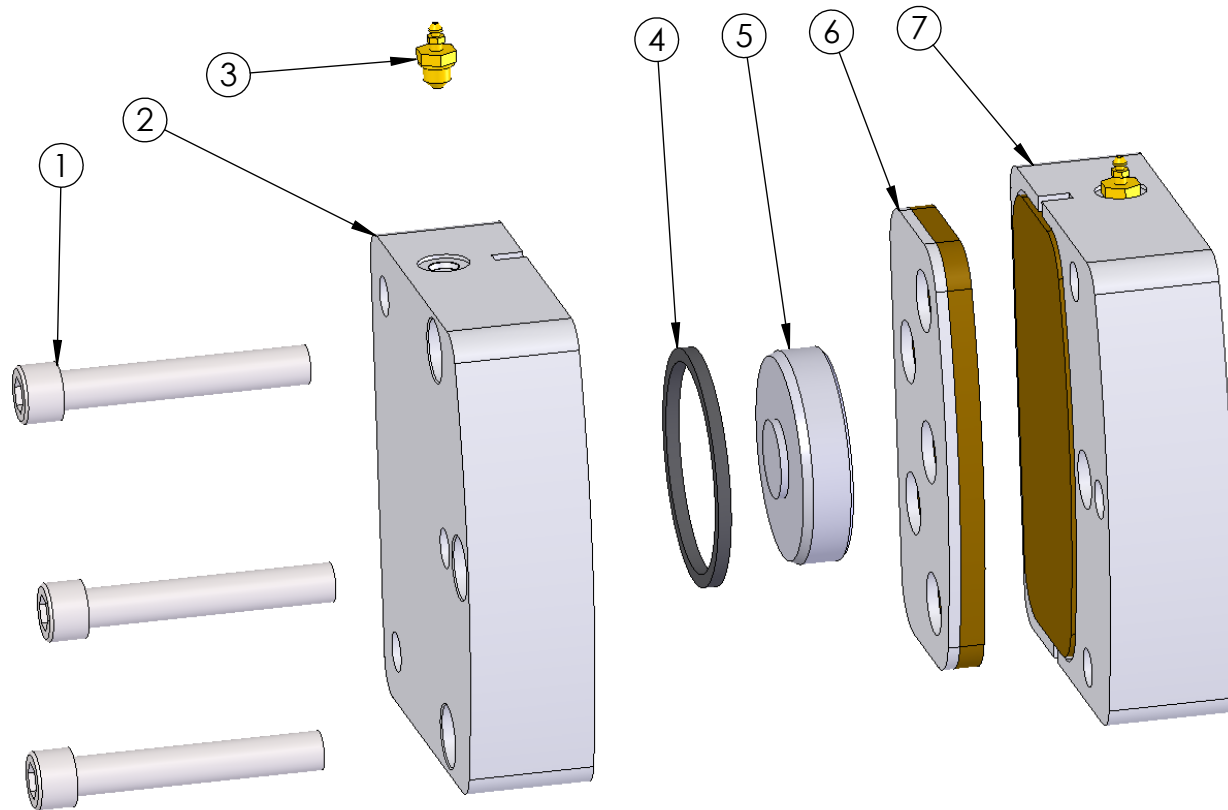

C04031A--Complete Assembly
(Contains all Parts Listed Below)

ITEM NO.	PART NUMBER	DESCRIPTION	QTY.
1	S04141	Screw SHCS 5/8-18x4	3
2	C04037	Caliper Half, Countersink	1
3	B18005	Bleeder, -4 o-ring	2
4	O01225	O-Ring, Piston	2
5	P08004	3-3/8" Piston	2
6	P01012	Pad, 7" HD brake caliper	2
7	C04038	Caliper Half, Threaded	1

Brake, Ausco 2007-2009

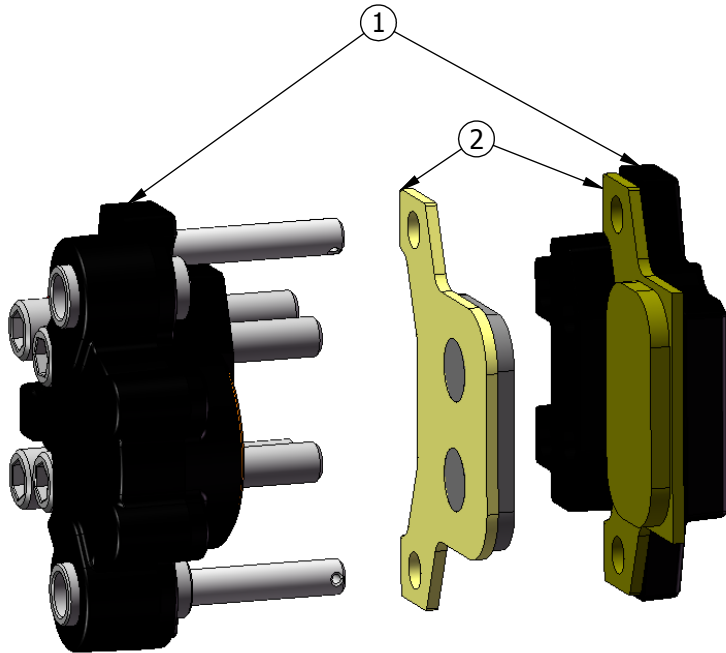

Brake, Mico Thru 2006, and in 2010

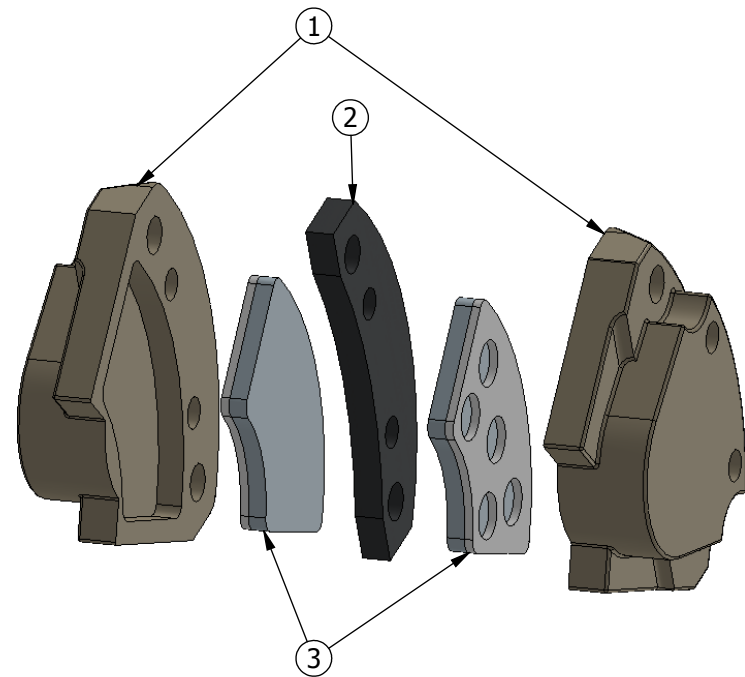

ITEM NO.	PART NUMBER	DESCRIPTION	QTY.
1	C04312	Caliper, Ausco	1
2	P01052	Pad Set, Ausco	2

ITEM NO.	PART NUMBER	DESCRIPTION	QTY.
1	C04910-001	caliper side	2
2	C04910-002	spacer	1
3	P01055	Pad mico woven	2

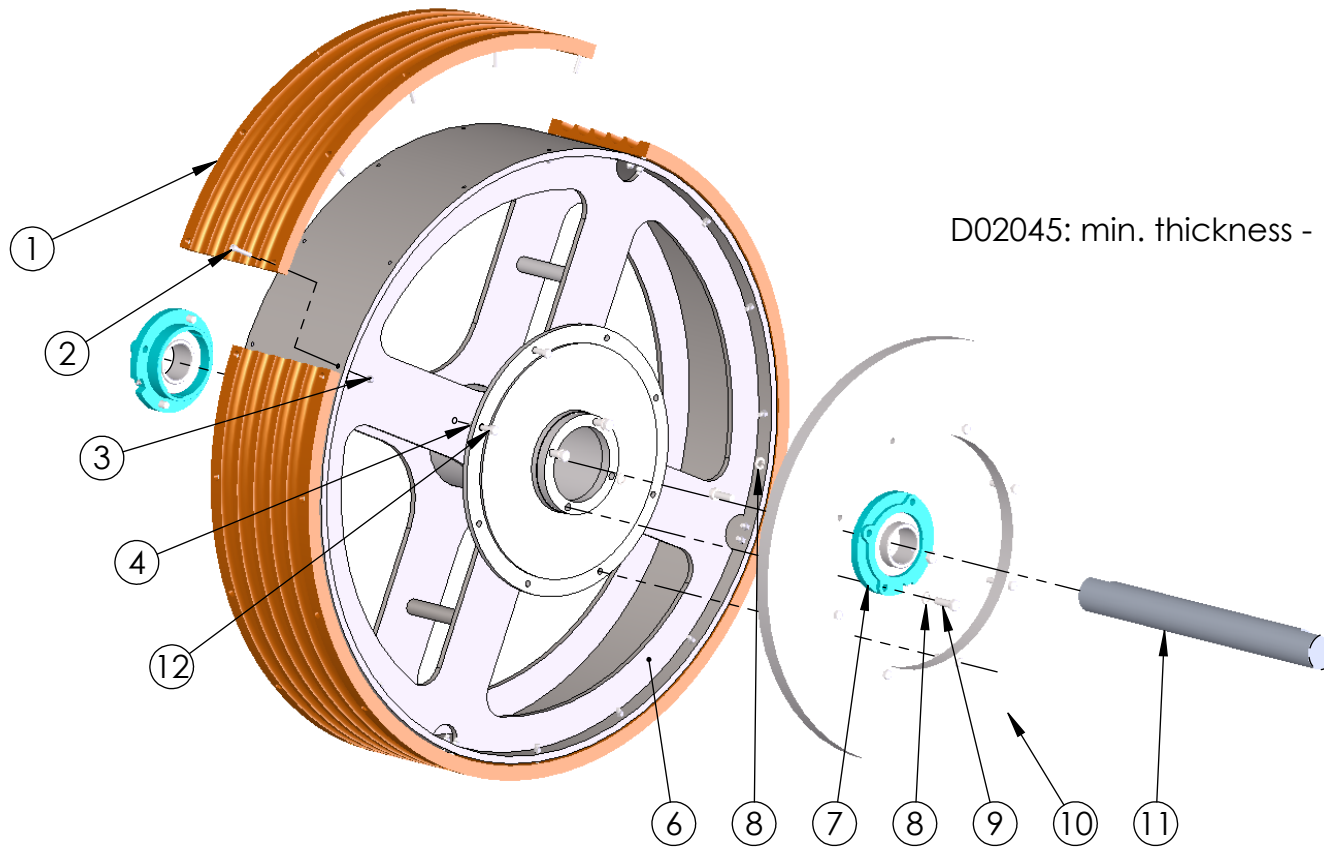

D02045: min. thickness - 1.1875"

ITEM NO.	PART NUMBER	DESCRIPTION	QTY.
1	L05010	Polyurethane Liner	4
2	S04021	Screw, SHCS 3/8"-16 x 2"	40
3	N04545	Nut, Hx Nylock® 3/8"-16	40
4	N04555	Nut, Hx Nylock® 1/2"-13	8
5	W01005	Washer, Flat SAE 1/2"zinc	8
6	C27009	Core, Bullwheel	1
7	B07006	Bearing, Flange 3"	2
8	W01040	Washer, Split Lock 5/8"zinc	8
9	B11376	Bolt, Hx Head 5/8"-11 x 2"	8
10	D02045	36" X 3/4" DISC BRAKE	1
11	S43998	Shaft	1
12	B11137	Bolt, Hx Head 1/2"-13 x 2-3/4" Z8	8

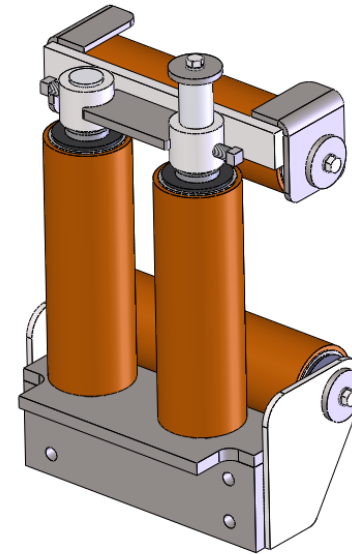
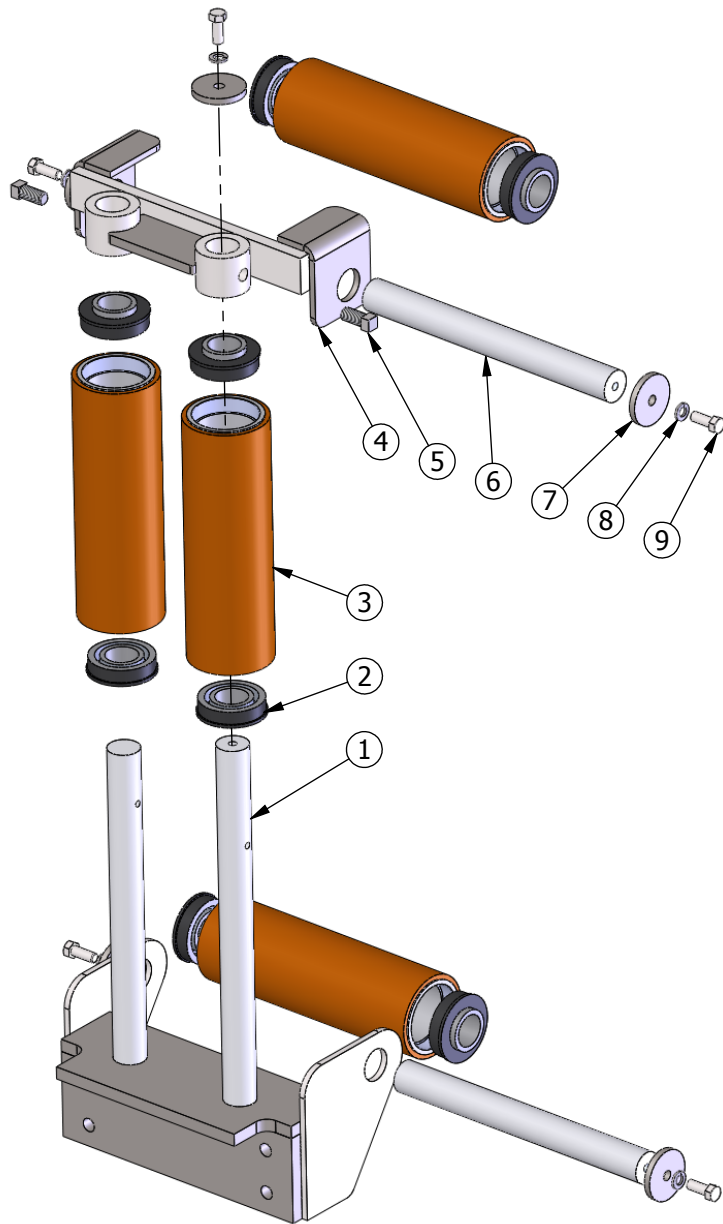

NOTE: ITEM #1 (BASE) MAY VARY, ALL OTHER PARTS ARE THE SAME

ITEM NO.	PART NUMBER	DESCRIPTION	QTY.
1	F09110	Base	1
2	B07110	Bearing, Roller	8
3	R20028	Roller, 10" w/ Polyurethane Coating	4
4	B15899	Fairlead Top Bracket	1
5	S04475	Screw, Set Sq Head 1/2 x 1	2
6	S43129	Shaft, Roller	2
7	C06041	Cap, End	5
8	W01545	Washer, Lock Split 3/8" Zinc	5
9	B11175	3/8-16 x 1" Hex Bolt	5

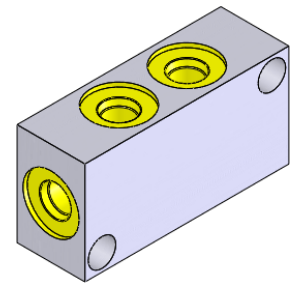
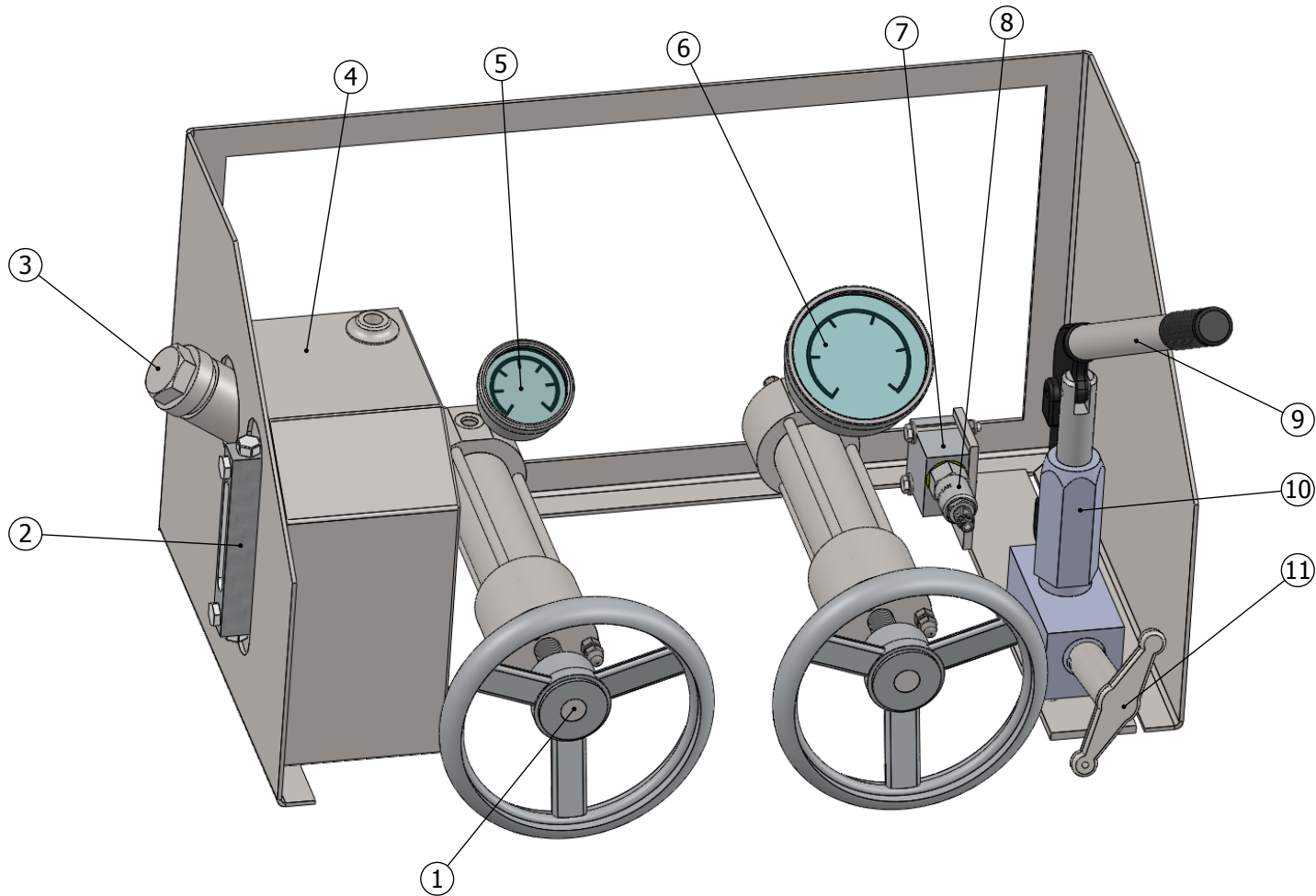

**M04050
Manifold, Distribution
Located on Frame below
Bullwheel Brakes**

ITEM NO.	PART NUMBER	DESCRIPTION	QTY.
1	C32004	Brake Cylinder	2
2	G02046	Gauge, Hyd oil level	1
3	F05212	Plug, 1"	1
4	T01011	Tank, Hyd oil	1
5	G02008	Gauge, 3" 600PSI	1
6	G02007	Gauge, 4" 600PSI	1
7	M04051	Manifold, Aluminum	1
8	V02077	Valve, Vickers Relief	1
9	H02026	Handle, Hydraulic pump	1
10	P20016	Hydraulic Pump, Manual	1
11	H02030	Handle, Hyd Pump Release	1

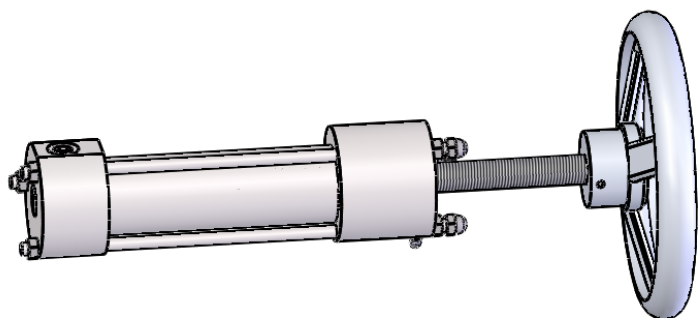
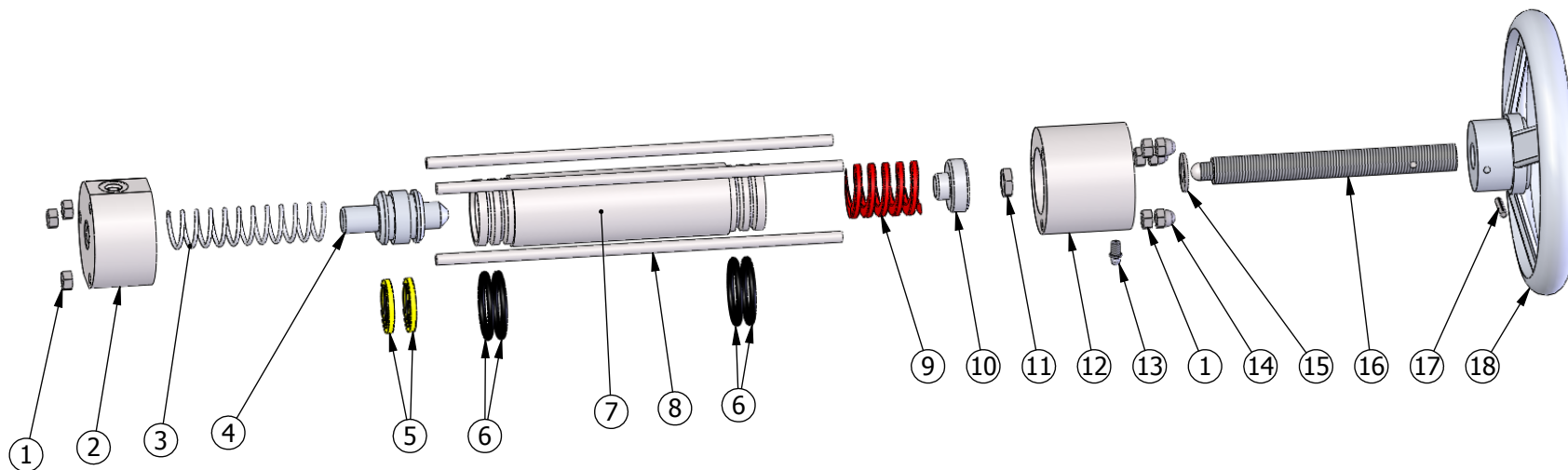

ITEM NO.	PART NUMBER	DESCRIPTION	QTY.
1	N04107	Nut Hex 5/16"-18	6
2	C06009	Bar round 3" 1018	1
3	S28022	Return Spring	1
4	P08017	Piston, Aluminum two groove	1
5	O01061	Seal	2
6	O01060	O-Ring	4
7	H08003	Cylinder Tube	1
8	R19007	Bar round 5/16" 1018	3
9	S28021	Spring	1
10	P08016	2" Aluminum RB	1
11	N04039	Nut Hex Jam 1/2-20	1
12	C06012	Bar round 3" 1018	1
13	F05630	Fitting, 1/4"-28 Zerk	1
14	N04103	Nut Hex 5/16"-18 Acorn	3
15	W01005	Washer, Flat SAE 1/2"	1
16	S04006-001	Bar 3/4"-8 acme thread	1
17	P06186	Pin, Roll 3/16 "x 1"	1
18	H02060	Handle, 8" Dia.	1

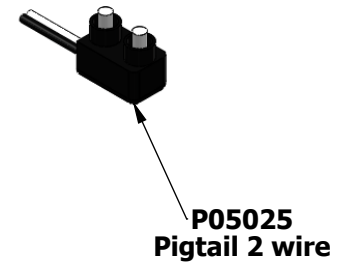
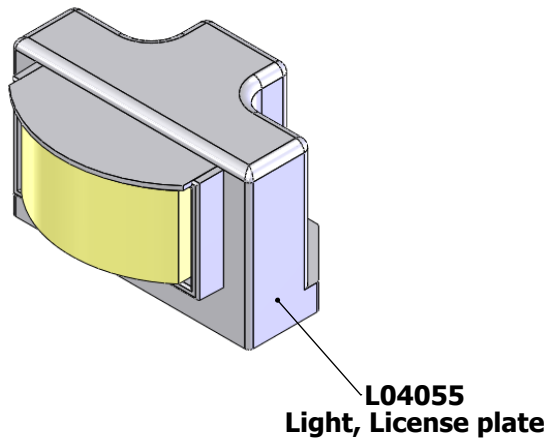
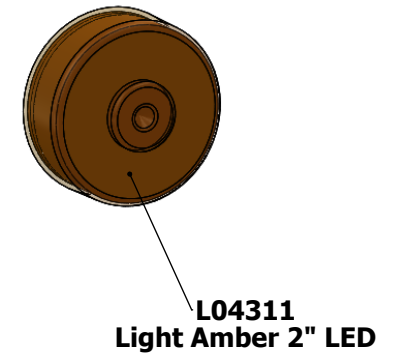
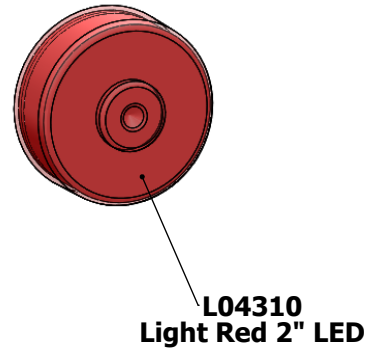
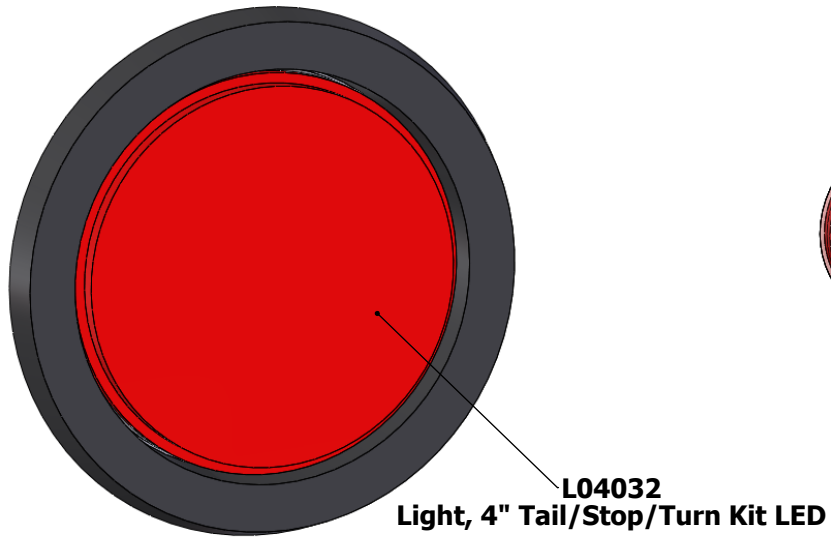

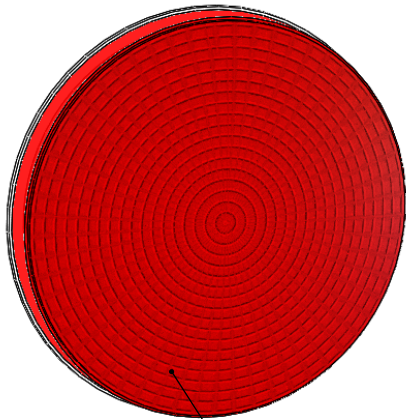

L04030
Light, 4" Tail Stop Turn

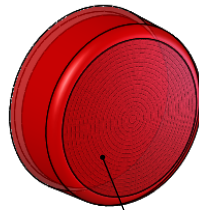

L04070
Light, 2" Red

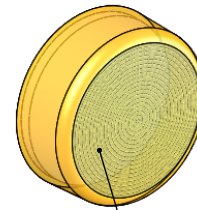

L04035
Light, 2" Amber

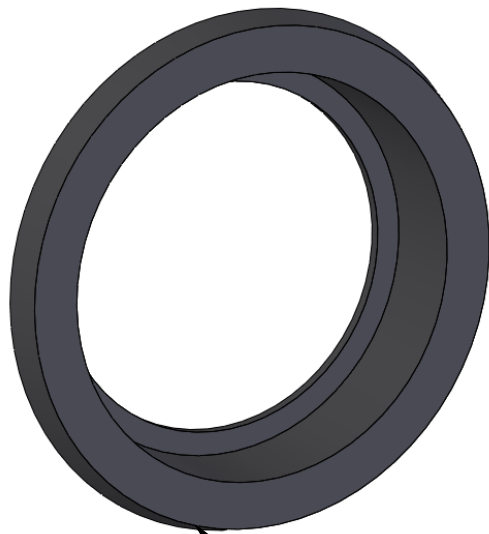

G08010
Grommet, 4" Tail/Stop/Turn

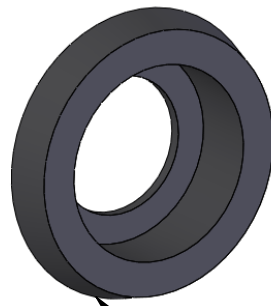

G08005
Grommet 2" Light

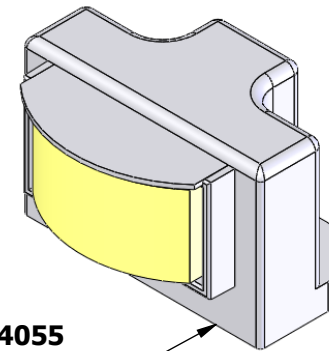

L04055
Light, License plate

Step 4: crack fitting to let any trapped air out
not all systems may have a gauge

Step 3: crack bleeder and
pump oil through system until
no more air comes out of caliper

Step 5: pump system up to @ 500psi and look for
leaks. When finished, let the pressure in the system
reach zero, then disconnect oil supply.

Step 2: attach pressurized hydraulic oil
source to connector if needed
ISO46 hydraulic oil

Step 1: back handle all the way
out, turn in 1-1/2 turns.

C28072 male
quick connect
fitting

Pad set - P01012
pads @3/8" thick

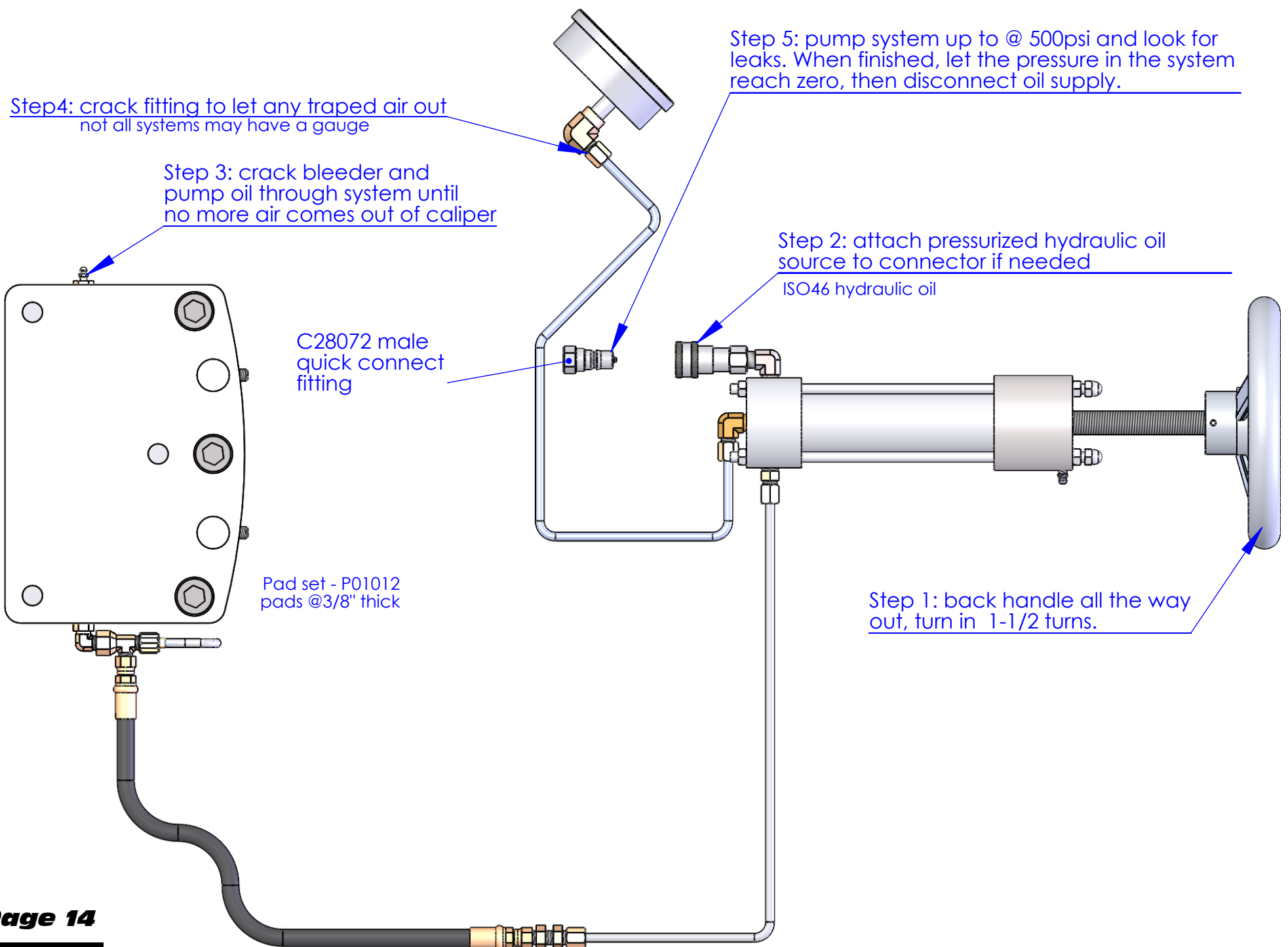

Hogg & Davis, Inc.

OLT-52B

Overhead Line Tensioner

Trailer Specifications

- Welded 6" x 4" tubular steel frame fully welded and reinforced
- Heavy Gauge fenders with mud flap
- Metal grit blasted, baked primer coat, 2 coat baked on PPG Sherwin Williams Genesis II paint
- Painted prior to assembly
- Adjustable 3" diameter Pintle hitch
- Heavy Duty center drop leg jack with manual crank and sand shoe
- Wiring to be installed inside the tubular steel frame with terminal blocks and wire guards standard. All end connections to be round eyes with heat shrink and connection to be bolted onto the terminals.
- Double shock mounted Lexan Lens Lights with pigtail connectors (FMVSS108)
- Conspicuity Tape (FMVSS108)
- Zinc Plated, Quick Release Jack stands
- 16,000 GAWR with tandem leaf springs Axles
- Electric applied brakes on both axles
- Tires four 235/85/16 14 ply

Bull Wheels

- Maximum rated tension is 5,000 pounds
- 2 – Multi-groove bullwheels that can handle up to a 1.5 inch diameter conductor
- Bull wheels are canted to handle both conventional conductor and fiber optic cables without causing them to twist.
- 2 – Stainless Steel HRAP 36" diameter tensioning brakes with hydraulic brake calipers on both bullwheels.
- Bullwheel outside diameter is 54 inches and the diameter at the bottom of the groove is 52 inches.
- Single rotary adjustment control for fine metering and a visual pressure gauge for applying the hydraulic brakes on both bull wheels.
- There are three Urethane Diameter Molded linings segments on each bull wheel that are easily replaceable. Segments do not have any spaces in between them for pulling rope or other objects to get snagged.
- Bull wheels are open reeved type for easy conductor installation and removal

Reel Carrier

- Reel capacity is 12,000 pounds of payload
- Maximum: Reel diameter 96"
Reel width 52"

- Reel and reel shaft are easily to disassemble for changing out reels without tools.
- The reel spindle has a 16" diameter bronze over spin brake with manual brake caliper as standard equipment
- Urethane lined roller fairlead to insure proper alignment with

Optional Equipment

- 1) Manual crank type retriever to rewind short lengths of conductor
- 2) Hydraulic retriever to rewind short lengths of conductor back onto the reel. The hydraulic retriever is attached directly to a sprocket on the shaft behind the brake caliper assembly. Controls are with a self centering valve with a directional control. Quick disconnects are standard for hydraulic pressure from the line truck or a separate hydraulic power pack. Reels can free wheel by disengaging the hydraulic motor from the drive system.
- 3) Hydraulic Brake Caliper in lieu of the manual type, with controller located next to the bull wheel controls.
- 4) Hydraulic Power Pack – 13HP Honda Air Cooled gasoline engine with 2500 psi.
- 5) Hydraulic outriggers with localized controls and audible alarm.
- 6) ABS Air Brake on the axles instead of the standard electric brakes

Wheel Torque Requirements

Be sure to use only the fasteners matched to the cone angle of your wheel (usually 60° or 90°). The proper procedure for attaching your wheels is as follows:

1. Start all bolts or nuts by hand to prevent cross threading.
2. Tighten bolts or nuts in the sequence shown for wheel torque requirements.
3. The tightening of the fasteners should be done in stages. Following the recommended sequence, tighten fasteners as shown in the chart below.
4. Wheel nuts/bolts should be torqued before first road use and after each wheel removal. Check and re-torque after the first 10 miles, 25 miles and again at 50 miles. Check periodically thereafter.

Wheel Size	1st Stage	2nd Stage	3rd Stage
12"	20-25	35-40	50-75
13"	20-25	35-40	50-75
14"	20-25	50-60	90-120
15"	20-25	50-60	90-120
16"	20-25	50-60	90-120
16.5" x 6.75"	20-25	50-60	90-120
16.5" x 9.75"	55-60	120-125	175-225
14.5" Demount	Tighten Sequentially to		85-95
17.5" Hub Pilot Clamp Ring & Cone Nuts	50-60	100-120	190-210
17.5" Hub Pilot 5/8" Flange Nuts	50-60	90-200	275-325

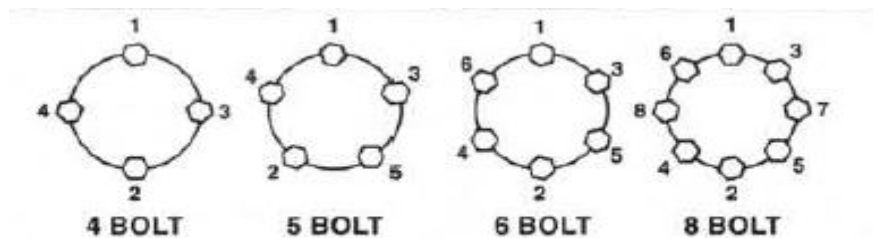

Maximum Wheel Fastener Torque

The wheel mounting studs used on Dexter Axles conforms to the SAE standards for grade 8. The maximum torque level that can be safely applied to these studs is listed in the following chart:

Stud Size	Max. Torque
1/2"-20 UNF, class 2A	120 lb ft.
9/16"-18, class 2A	170 lb ft.
5/8"-18, class 2A	325 lb ft.

CAUTION

Exceeding the above listed torque limits can damage studs and/or nuts and lead to eventual fractures and dangerous wheel separation.



D30001
(1)



D30010
(2)



D30015
(3)



D30034
(3)



D30042
(8)

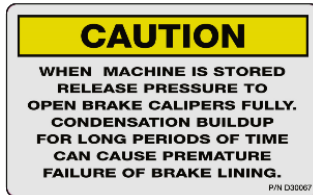

D30067
(2)



D30098
(2)



D30017
(1)

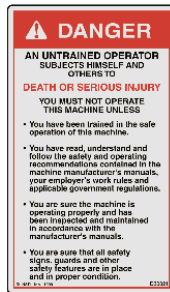

D30021
(1)



D30026
(3)

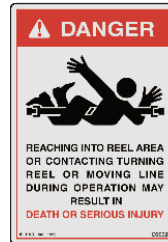

D30028
(5)

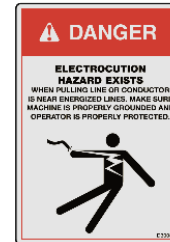

D30036
(5)



D30127
(3)

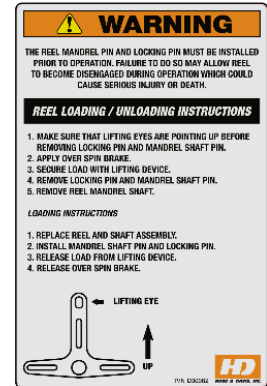

D30082
(1)



T19001
(9)

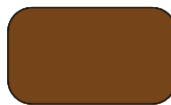

R09044
(2)



R09043
(4)

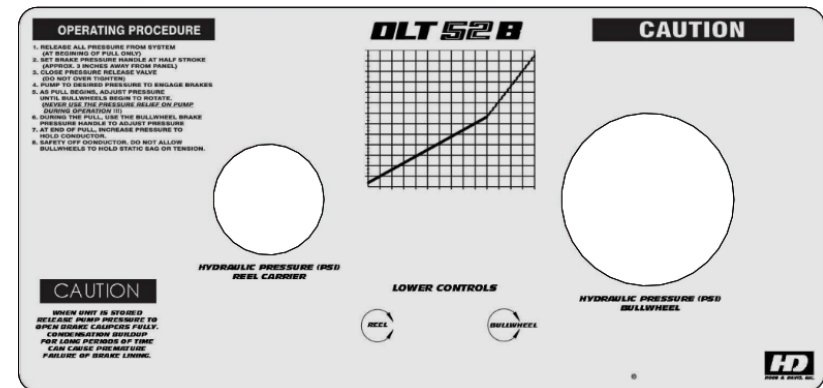

D30099
(1)

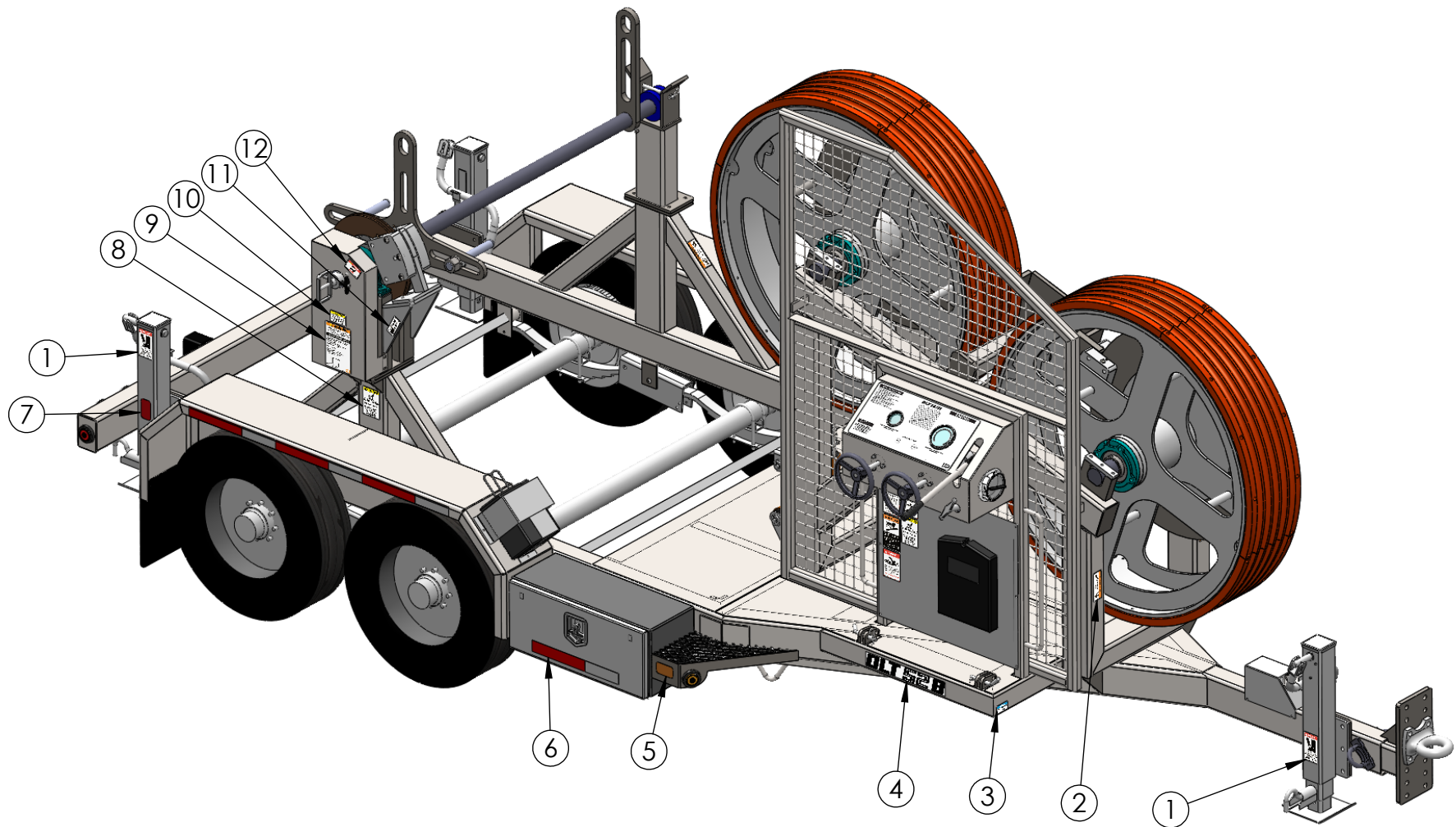

ITEM NO.	PART NUMBER	DESCRIPTION	QTY.
1	D30026	Decal, Danger Stand Clear	3
2	D30042	Decal, Keep Hands Clear	8
3	D30034	Decal, Grounding Lug	3
4	D30098	Decal, OLT52 Tongue	2
5	R09044	Reflector, Amber 2x3-1/2	2
6	T19001	Red/White Reflective tape	9
7	R09043	Reflector, Red 2x3-1/2	4
8	D30127	Decal, Burn Hazard	3
9	D30082	Decal, Reel Loading Inst.	1
10	D30067	Decal, Release Pressure	2
11	D30010	Decal, Hydraulic Fluid Only	2
12	D30015	Decal, Hot Surface	3

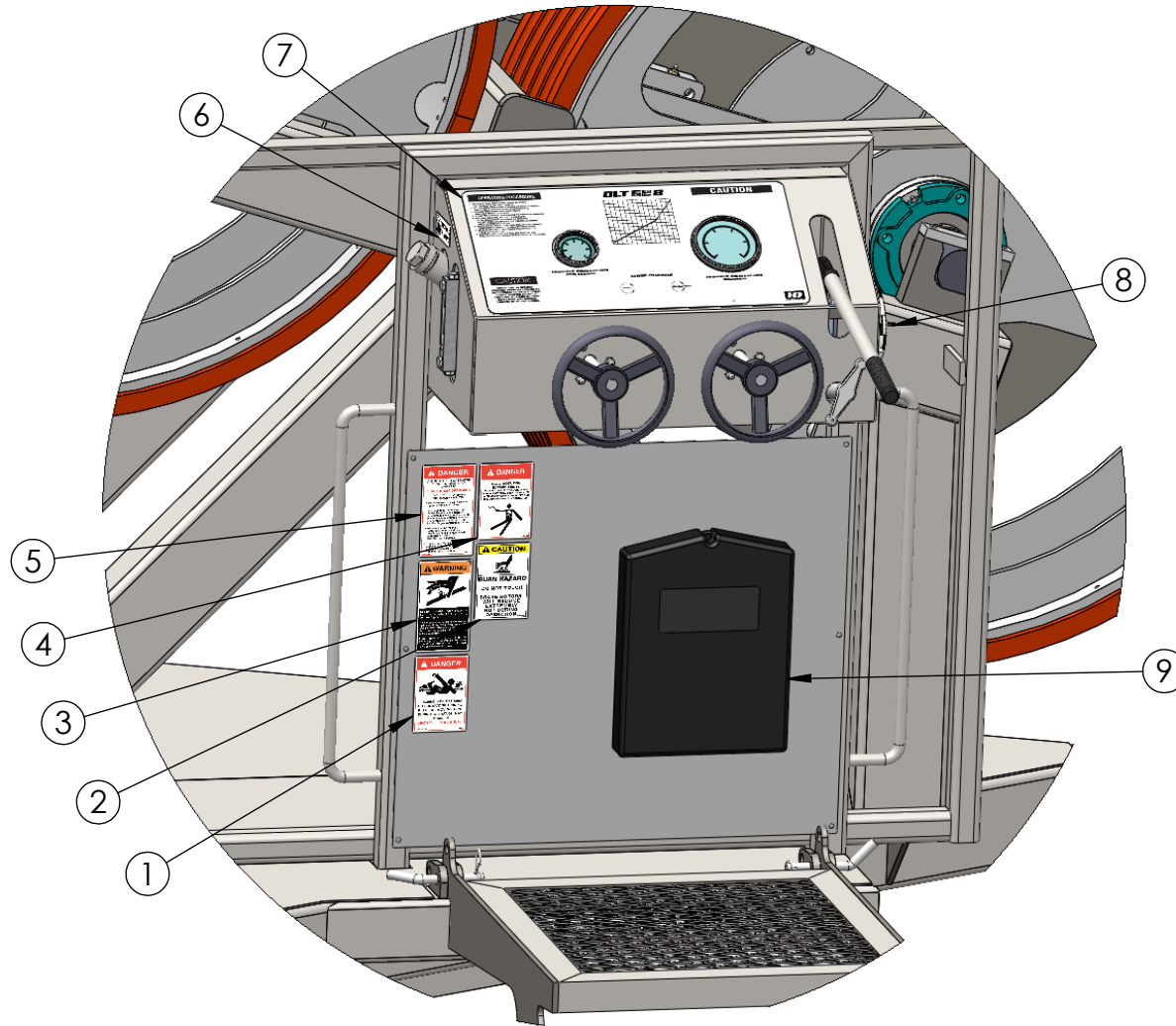

ITEM NO.	PART NUMBER	DESCRIPTION	Qty
1	D30028	Decal, Danger Twisty Man	5
2	D30127	Decal, Burn Hazard	3
3	D30017	Decal, Danger Fluid Pressure	1
4	D30036	Decal, Electrocution Hazard	5
5	D30021	Decal, Untrained Operator	1
6	D30010	Decal, Hydraulic Fluid Only	2
7	D30099	Decal, Control Panel	1
8	H10020	Holder, Registration	1
9	H10075	Holder, Manual	1

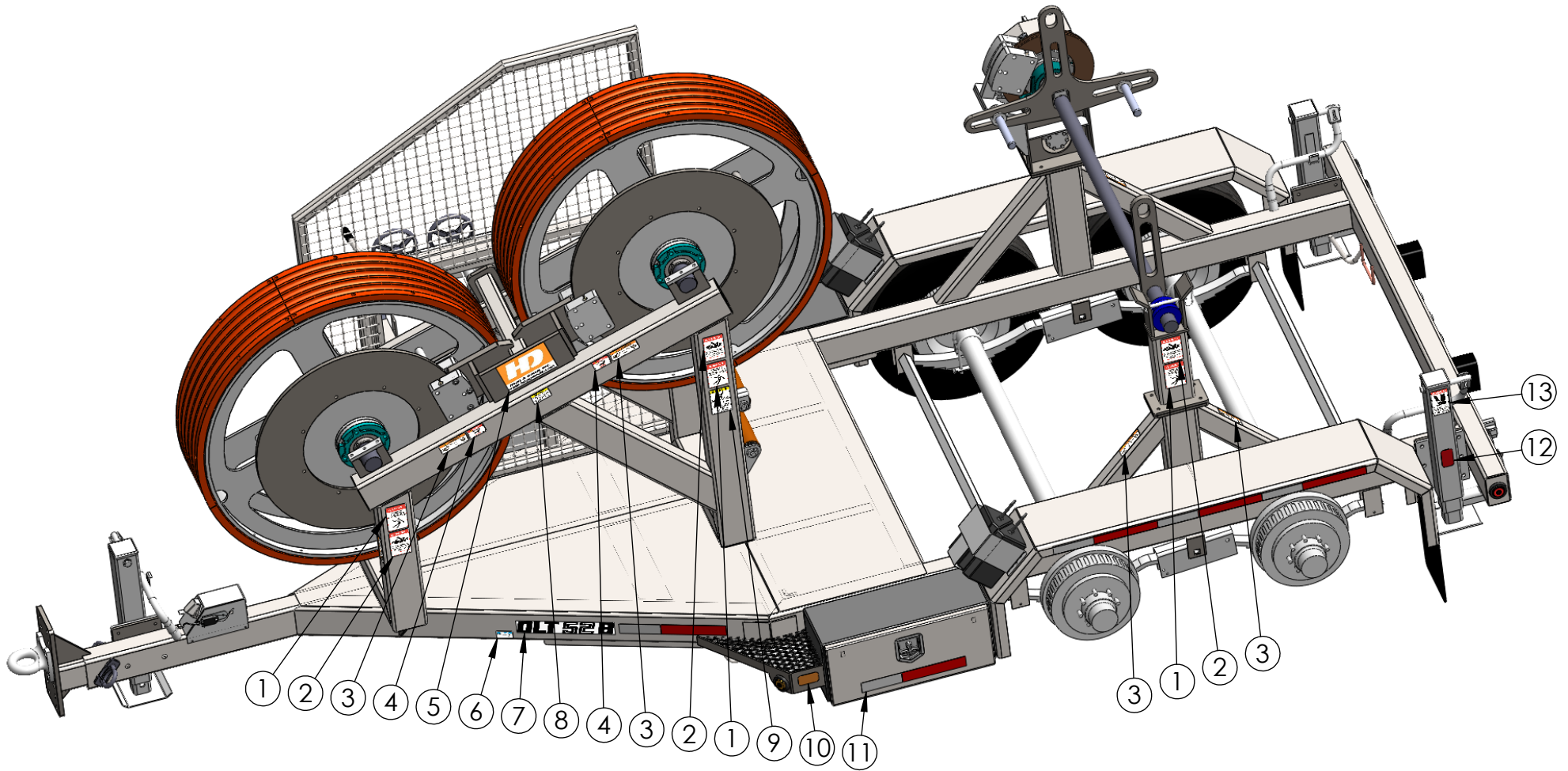

ITEM NO.	PART NUMBER	DESCRIPTION	QTY.
1	D30036	Decal, Electrocution Hazard	5
2	D30028	Decal, Danger Twisty Man	5
3	D30042	Decal, Keep Hands Clear	8
4	D30015	Decal, Hot Surface	3
5	D30001	HD Logo 6x9	1
6	D30034	Decal, Grounding Lug	3
7	D30098	Decal, OLT52 Tongue	2
8	D30067	Decal, Release Pressure	2
9	D30127	Decal, Burn Hazard	3
10	R09044	Reflector, Amber 2x3-1/2	2
11	T19001	Red/White Reflective tape	3
12	R09043	Reflector, Red 2x3-1/2	4
13	D30026	Decal, Danger Stand Clear	3

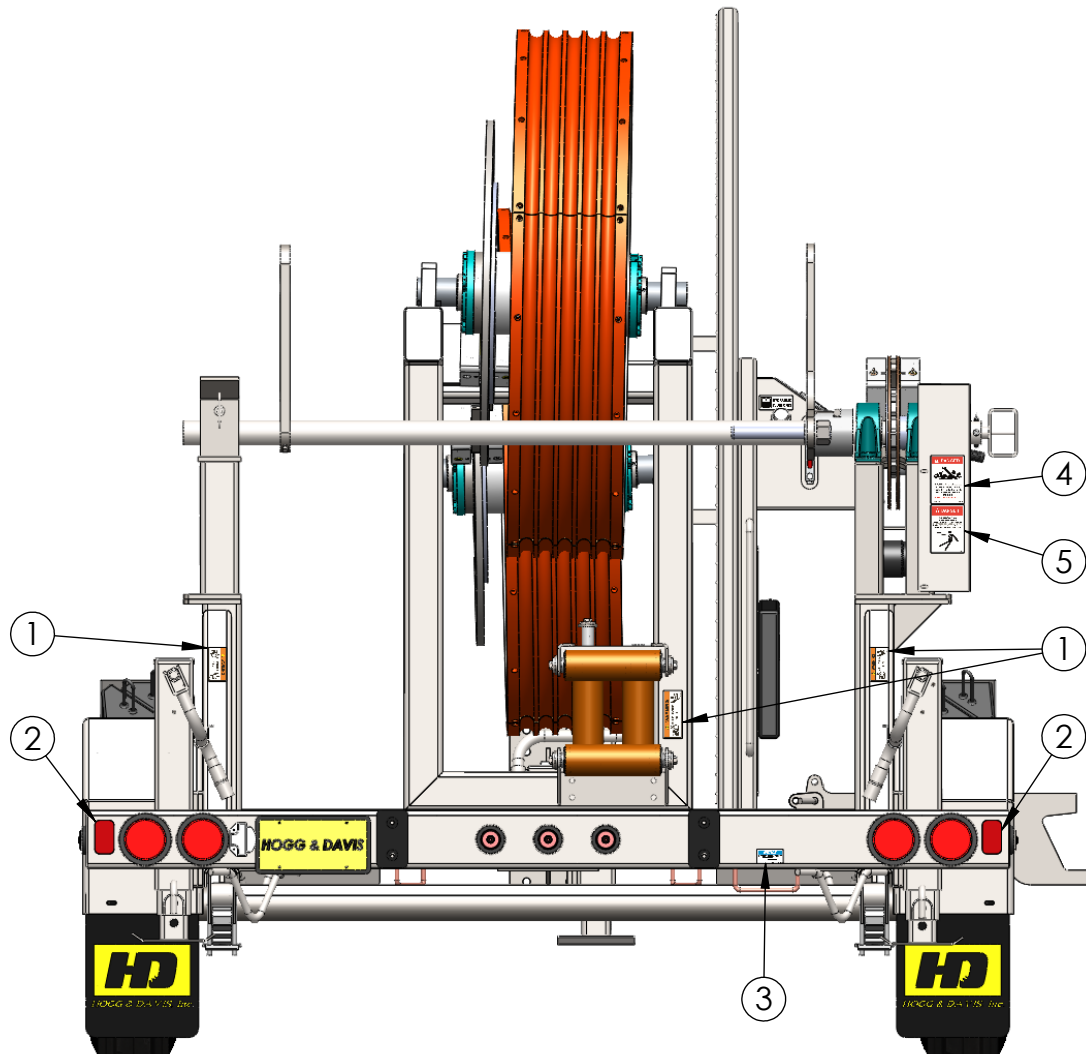

ITEM NO.	PART NUMBER	DESCRIPTION	QTY.
1	D30042	Decal, Keep Hands Clear	8
2	R09043	Reflector, Red 2x3-1/2	4
3	D30034	Decal, Grounding Lug	3
4	D30028	Decal, Danger Twisty Man	5
5	D30036	Decal, Electrocution Hazard	5