



# TEREX

## HI-RANGER

### XT PRO SERIES

# OPERATOR'S MANUAL

This Operator's Manual **MUST BE READ** prior to operating your  
XT PRO SERIES Overcenter Articulating Aerial Device.

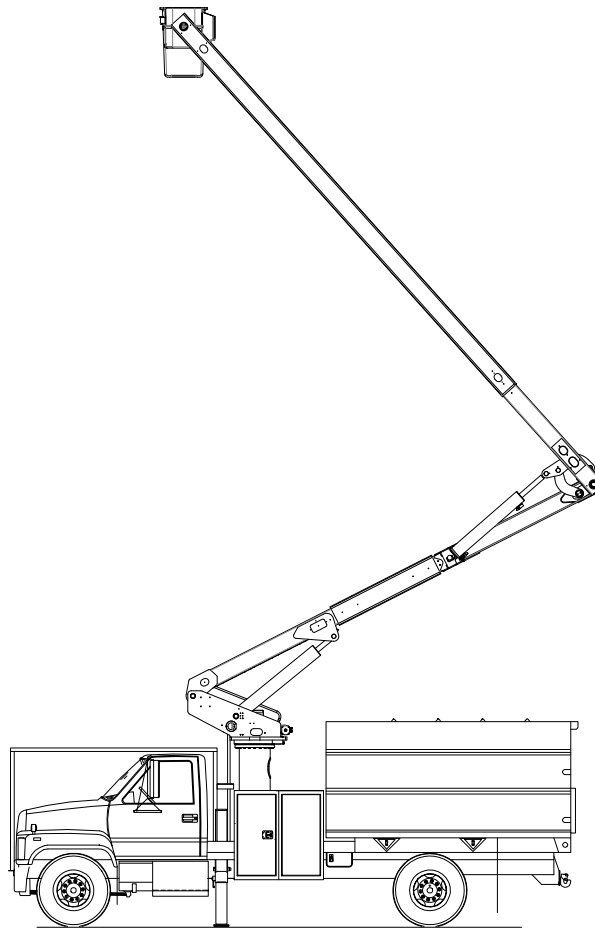

PRINTED IN THE USA  
Original Instructions in English

Terex South Dakota, Inc.  
500 Oakwood Road  
Watertown, SD 57201

### **CALIFORNIA PROPOSITION 65**

**⚠ Warning:** Operating, servicing or maintaining this equipment can expose you to chemicals including engine exhaust, carbon monoxide, phthalates, and lead, which are known to the State of California to cause cancer and birth defects or other reproductive harm. These chemicals can be emitted from or contained in other various parts and systems, fluids and some component wear by-products. To minimize exposure, avoid breathing exhaust, do not idle the engine except as necessary, service your equipment and vehicle in a well-ventilated area and wear gloves or wash your hands frequently when servicing your equipment or vehicle and after operation. For more information go to [www.P65Warnings.ca.gov/passenger-vehicle](http://www.P65Warnings.ca.gov/passenger-vehicle).



# TABLE OF CONTENTS

- INTRODUCTION** . . . . . - I
- OWNERS, USERS AND OPERATORS . . . . . - I
- PRODUCT IDENTIFICATION . . . . . - I
- INTENDED USE . . . . . - I
- UNAUTHORIZED USE . . . . . - II
- BULLETIN DISTRIBUTION AND COMPLIANCE . . . . . - II
- CONTACTING THE MANUFACTURER . . . . . - II
- TRANSFER OF MACHINE OWNERSHIP . . . . . - II
- SAFETY** . . . . . - III
- HAZARD CLASSIFICATION SYSTEM . . . . . - III
- PROPERTY DAMAGE MESSAGES . . . . . - III
- BEFORE OPERATION . . . . . - VI
- DURING OPERATION . . . . . - VII
- ELECTRICAL HAZARDS . . . . . - VIII
- ACCESSORIES . . . . . - IX
- TRAVELING . . . . . - IX
- MAINTENANCE . . . . . - X
- OVERVIEW OF POTENTIAL HAZARDS AND SYMBOLS . . . . . - X
- SAFETY RELATED DECALS** . . . . . - XIII
- WHAT IS INSULATED AND NOT INSULATED** . . . . . - XXIII
- UPPER BOOM RATING . . . . . - XXIII
- WHAT IS INSULATED . . . . . - XXIV
- ELECTRICAL INSULATION . . . . . - XXVI
- PREVENTION OF ELECTROCUTION . . . . . - XXVII
- OPERATION ON OR NEAR ENERGIZED CONDUCTOR . . . . . - XXVII
- SECTION 1** . . . . . 1 - 1
- OPERATION GUIDELINES** . . . . . 1 - 1
- NOMENCLATURE . . . . . 1 - 1
- CAB CONTROLS . . . . . 1 - 2
- MASTER CONTROL . . . . . 1 - 2
- POWER TAKE-OFF (OPTIONAL) . . . . . 1 - 2
- CONTROLS BELOW ROTATION . . . . . 1 - 4
- FORESTRY VEHICLE . . . . . 1 - 4
- UTILITY VEHICLE . . . . . 1 - 7
- OPERATOR CONTROLS AND DESCRIPTIONS . . . . . 1 - 9
- UPPER CONTROLS . . . . . 1 - 10
- SINGLE STICK . . . . . 1 - 10
- INDIVIDUAL LEVER . . . . . 1 - 14
- LOWER CONTROLS . . . . . 1 - 17
- BEHIND CAB MOUNT . . . . . 1 - 17
- REAR AXLE MOUNT . . . . . 1 - 18
- CONTROL SELECTOR . . . . . 1 - 19
- ACCESSORIES . . . . . 1 - 22
- ENGINE STOP/START CONTROL (OPTIONAL) . . . . . 1 - 22
- TWO-SPEED THROTTLE CONTROL (OPTIONAL) . . . . . 1 - 22
- AUXILIARY LET DOWN POWER CONTROL (OPTIONAL) . . . . . 1 - 22
- HYDRAULIC TOOLS (OPTIONAL) . . . . . 1 - 23
- PLATFORM TILTING OPERATION (OPTIONAL) . . . . . 1 - 24
- MECHANICAL TILTING (CONTROLS BETWEEN BOOM AND PLATFORM) . . . . . 1 - 24



LOADING CAPACITIES ..... 1 - 25

HYDRAULIC PLATFORM TILTING (OPTIONAL) ..... 1 - 26

PERSONNEL AND TRAINING ..... 1 - 27

PRE-OPERATION ..... 1 - 28

    DAILY PRE-OPERATION CHECKS ..... 1 - 28

    JOB SITE SURVEY ..... 1 - 28

    OPERATING TEMPERATURE RANGE ..... 1 - 29

    WIND SPEED ..... 1 - 29

    JOB SITE SETUP ..... 1 - 30

    SETTING THE OUTRIGGERS ..... 1 - 32

    SETTING UP ON A slope ..... 1 - 33

    SETTING UP ON A SOFT SURFACE ..... 1 - 34

    SETTING UP FOR OPERATION ON SNOW AND ICE ..... 1 - 35

    OUTRIGGER/UNIT CONTROL SELECTOR ..... 1 - 35

    OUTRIGGER INTERLOCK ..... 1 - 36

    TORSION BARS (OPTIONAL) ..... 1 - 36

    STABILITY ..... 1 - 36

OPERATION ..... 1 - 37

    UNSTORE THE BOOM ..... 1 - 37

    BOOM OPERATION ..... 1 - 37

    AERIAL OPERATION ..... 1 - 38

    ENTERING THE PLATFORM ..... 1 - 38

    DUMPING CHIP BOX ..... 1 - 41

EMERGENCY OPERATION ..... 1 - 42

    POWER LINE CONTACT ON GROUND ..... 1 - 42

    CONTROL SELECTOR ..... 1 - 45

    MANUAL ROTATION ..... 1 - 45

    AUXILIARY LET DOWN POWER (OPTIONAL) ..... 1 - 45

HYDRAULIC LINE FAILURE ..... 1 - 46

    ENGINE FAILURE ..... 1 - 48

    HYDRAULIC PUMP FAILURE ..... 1 - 48

    CONTROL VALVE FAILURE ..... 1 - 48

OPERATIONAL LIMITATIONS ..... 1 - 48

    PLATFORM LEVELING SYSTEM ..... 1 - 48

    FALL ARREST ..... 1 - 49

    RESPONSE TO A FALL ..... 1 - 49

    STORING BOOMS FOR TRANSPORT ..... 1 - 50

LEAVING THE JOB SITE ..... 1 - 51

**SECTION 2 ..... 2 - 1**

**MAINTENANCE GUIDELINES ..... 2 - 1**

    PREVENTATIVE MAINTENANCE ..... 2 - 1

        MAINTENANCE PROCEDURE ..... 2 - 1

        ADJUSTMENTS AND REPAIRS ..... 2 - 1

        LUBRICATION ..... 2 - 2

        GENERAL INFORMATION ..... 2 - 2

    FREQUENT AND PERIODIC INSPECTION INTERVALS ..... 2 - 3

        DAILY, prior to each shift ..... 2 - 3

        180 DAYS (1,000 HOURS) ..... 2 - 3

        12 MONTHS (2,000 HOURS) ..... 2 - 3

        10 YEARS (20,000 HOURS) ..... 2 - 3

    CONTROL SYSTEM ..... 2 - 4



# XT PRO SERIES

OPERATIONAL TESTS.....	2 - 4
ELECTRICAL TESTS .....	2 - 4
POST EVENT INSPECTION AND TEST .....	2 - 4
LUBRICATION CHART .....	2 - 5
STORAGE PROCEDURE .....	2 - 6
RETURNING TO SERVICE.....	2 - 6
<b>APPENDIX - A.....</b>	<b>A - 1</b>
STANDARDS AND REGULATIONS .....	A - 1
OSHA EXCERPTS: (CLEARANCE DISTANCE).....	A - 2
STANDARD HAND SIGNALS.....	A - 4
<b>APPENDIX - B.....</b>	<b>B - 1</b>
RESPONSIBILITIES .....	B - 1
ANSI A92.2-2015 (PARTIAL) .....	B - 1
SURVEY OF JOB SITE.....	B - 13





# INTRODUCTION

## OWNERS, USERS AND OPERATORS

Thank you for choosing Terex South Dakota, Inc. equipment for your application. User safety is our number one priority and this is best achieved by our joint efforts.

As equipment users and operators, you make a major contribution to safety if you:

1. Comply with OSHA, federal, state, ANSI, local and your company regulations.
2. Read, understand and follow the instructions in this manual and other manuals supplied with this vehicle.
3. Only allow trained operators, directed by informed and knowledgeable supervision, to run the unit.

If there is anything in this manual that is not clear or you believe should be added, please send your comments to:

Manager of Publications  
 Terex South Dakota, Inc.  
 500 Oakwood Road  
 Watertown, South Dakota 57201

You may also contact us by phone at: (605) 882-4000



**This is the safety alert symbol. It is used in this manual to alert you to potential personal injury hazards. Obey all safety messages that follow this symbol to avoid possible injury or death.**

This manual contains important information on the safe use of your Terex South Dakota, Inc. equipment. Your failure to read, understand and follow all safety rules, warnings and instructions will unnecessarily expose you and others to dangerous situations. For your safety and the safety of those around you, you **must** operate your Terex South Dakota, Inc. equipment as instructed in this manual.

This manual shall be stored on the vehicle for access by the operator. The Operators manual is required to be stored on the vehicle by ANSI and OSHA regulations. This manual, along with the AEM Aerial Devices Safety Manual and ANSI A92.2 Manual of Responsibilities for Dealers, Owners, Users, Operators, Lessors and Lessees should be considered a permanent part of your machine and should remain with the machine at all times.

## PRODUCT IDENTIFICATION

The serial number is located on the ID plaque. It may be located on the turntable, pedestal or lower boom, depending on options and features. The serial number of the vehicle (VIN) will be different than the serial number for the aerial device. Please refer to the aerial device serial number when contacting Terex South Dakota, Inc. for service and parts information. Refer to the ID plaque for capacity and dielectric information.

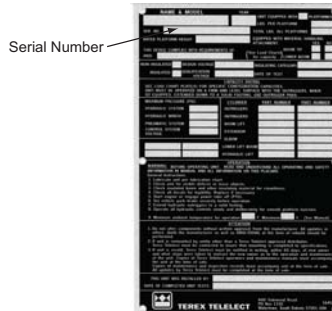

## INTENDED USE

This machine is a tool intended to be used by trained and qualified operators to lift personnel, along with tools to an aerial work site within the rated platform capacity. Use of this product in any other way is prohibited and contrary to its intended use.



**UNAUTHORIZED USE**

Secure the vehicle to prevent persons who are not authorized to operate the vehicle and unit. Examples include removing the keys, securing tools and materials, and locking compartments.

**BULLETIN DISTRIBUTION AND COMPLIANCE**

It is the owners responsibility to comply with all bulletins issued by Terex South Dakota, Inc. or the vehicle manufacturer. Safety of product users is of paramount importance to Terex South Dakota, Inc. Various bulletins are used by Terex South Dakota, Inc. to communicate important safety and product information to dealers and machine owners. The information contained in bulletins is tied to specific machines using the machine model number and serial number. Distribution of these bulletins is based on the most current owner on record along with their associated dealer, so it is important to register your machine and keep your contact information up to date and changes in ownership. To ensure safety of personnel and the reliable continued operation of your machine, compliance with the information and actions in the bulletins are mandatory.

	<b>Failure to register your machine means you will not receive important information that may impact your safety.</b>
---	---

**CONTACTING THE MANUFACTURER**

If it is necessary to contact the manufacturer of the machine, supply the unit model number, serial number and your name and contact information. At minimum, the manufacturer should be contacted for:

- Accident Reporting
- Questions regarding product applications and safety
- Standards and regulations compliance information
- Questions regarding product modifications
- Current owner updates, such as changes in machine ownership or changes in your contact information (See Transfer of Machine Ownership below)

**TRANSFER OF MACHINE OWNERSHIP**

If you are not the original owner of this machine, make a copy of the following form to provide information on the ownership change.

This information will ensure that you are the owner on record for this machine and you will receive applicable notices and advisories in a timely manner.

You can mail information on changes in ownership to Terex South Dakota, Inc., 500 Oakwood Road, PO Box 1050, Watertown, SD 57201 or email the information shown below to: [utilities.warranty@terex.com](mailto:utilities.warranty@terex.com).

REGISTRATION CARD

Terex South Dakota, Inc. Model \_\_\_\_\_ Serial # \_\_\_\_\_

Owner's Name			
Address			
City		State	Zip
Signed		Title	
Email :	Ph #:	Mobile #:	
VIN #		Customer Truck #	
Check: ( ) Operation & Maintenance Manual Received.			
Date Placed in Service:			
Previous Owner			
Address			

Note: If Operation & Maintenance Manual was not received, contact Terex South Dakota for copies.





# SAFETY

The operator is the single most important factor for safety when using any piece of equipment. Learn to operate your Terex South Dakota, Inc. equipment in a safe manner.

**NOTE: The best method to protect yourself and others from injury or death is to use common sense. If you are unsure of any operation, do not continue until you are satisfied that it is safe to proceed.**

## HAZARD CLASSIFICATION SYSTEM

This machine contains safety signs to assist in hazard recognition and prevention. The hazard classification system is a multi-tier system used to alert you to potential personal injury hazards. Signal words used with the safety alert symbol indicate a specific level of severity of the potential hazard. To help you recognize important safety information, we have identified **warnings** and **instructions** that directly impact safety.

	<b>This is the safety alert symbol. It is used in this manual to alert you to potential personal injury hazards. Obey all safety messages that follow this symbol to avoid possible injury or death.</b>
--	--

**Danger** is always used with the safety alert symbol and white letter on red background.

	Indicates a hazardous situation that, if not avoided, will result in death or serious injury.
--	---

**Warning** is always used with the safety alert symbol and black letters on orange background.

	Indicates a hazardous situation that, if not avoided, could result in death or serious injury.
--	--

**Caution** is used with the safety alert symbol and black letters on yellow background.

	Indicates a hazardous situation that, if not avoided, could result in minor or moderate injury.
--	---

## PROPERTY DAMAGE MESSAGES

The signal word **NOTICE**, shown without the safety alert symbol, is used to address specific practices or draw attention to supplemental information that is not related to personal injury.

**Notice** does not use the safety alert symbol and text is white italic letters on blue background.

	Indicates information considered important, but not hazard related (e.g., messages related to property damage).
--	---





**In addition to maintenance and operating instructions in this manual, the operator must read and understand all the instructions in the following safety guidelines.**

1. Study all safety messages and apply them on the job.
2. Modifications to this equipment from the original design specifications without written permission from Terex South Dakota, Inc. are strictly forbidden. A modification may compromise the safety of the equipment, subjecting users to serious injury or death. Any such modification will void any remaining warranty.
3. Terex South Dakota, Inc. reserves the right to change, improve, modify or expand features of its equipment at any time. Specifications, model or equipment are subject to change without notice and without incurring any obligations to change, improve, modify or expand features of previously delivered equipment.
4. Comply with manufacturer's instructions and requirements of current OSHA regulations and ANSI standards.
5. This unit is only a tool. The manual does not instruct users how to accomplish tasks assigned by the owner or user. Only training by your employer will instruct the operator and users how to accomplish the assigned task safely.





## GENERAL SAFETY GUIDELINES

1. The use of this Aerial Device is subject to certain potential dangers that cannot be protected against by mechanical means. Only the exercise of intelligence, care, and common sense can eliminate these dangers. It is essential to have competent, careful operators who are physically and mentally fit, and thoroughly trained in the safe operation of this Aerial Device. Learn, understand and practice safe use of all equipment and controls - before operating this Aerial Device.
2. Never exceed the rated load capacity. Know the total weight - including the operator, platform liner, tools, and equipment, and/or other items before entering platform.
3. Conduct a thorough pre-operation of the machine and test all functions through their complete cycle before each work shift. Immediately tag and remove from service a damaged or malfunctioning machine.
4. Do not operate this Aerial Device if any interlock or safety device is malfunctioning.
5. Do not bypass or remove any interlock or safety device.
6. Never operate with damaged leveling chain or components.
7. Stop in position if you become aware of any dangerous conditions or hear any unusual noise (such as grinding, cracking or grating) while operating the Aerial Device. Do not move the Aerial Device until the problem has been resolved.
8. Do not operate the Aerial Device if it is not functioning properly or a leak is detected. Repair, document repairs performed and inspect the unit before returning to service.
9. Never operate from the ground controls with personnel in the platform. Operation must be controlled by the platform operator, except in case of an emergency.
10. Keep your Aerial Device control area free of obstructions that may interfere with control operation or physical access to the controls.
11. All ground personnel must be trained in the proper procedures to follow in case of emergency.
12. Do not operate the Aerial Device in an electrical storm.
13. The hydraulic fluid is petroleum based and is flammable.
14. Perform all required inspection and maintenance.

**BEFORE OPERATION**

1. Survey the conditions of the work area. Identify situations such as; soft ground, ditches, drop-offs, holes, debris, overhead obstructions, electrical conductors, underground utilities, stored fuels, toxic dust and gases.
2. Plan the job (tailgate session) and clear the area of unauthorized personnel.
3. Set the vehicle parking brake and chock the wheels.
4. Make certain tire pressures are proper for operation.
5. Visually inspect condition of tires, truck suspension, and torsion bars (if equipped) for any damage.
6. The vehicle must be securely parked and stabilized before any operation is performed. If equipped with outriggers, set all outriggers.
7. If not equipped with outriggers, or only one set of outriggers, the truck tires must equally support the weight of the truck. One tire cannot be in a hole or depression.
8. Do not lower outriggers unless you can see that all personnel are clear of the outrigger path of movement and its ground contact point. Lower all outriggers onto solid footing.
9. Do not place outriggers on ice as slippage may occur regardless of solid footing. Operation on snow or slippery surfaces requires extra care during set up to ensure Aerial Device and vehicle have sufficient traction to prevent sliding.
10. The Aerial Device has been tested per the stability requirements of ANSI A92.2 and may be operated on firm, flat, non-level surfaces up to a 5 degree slope.
11. Ground and/or barricade the vehicle per OSHA, ANSI and your company policies.
12. Only operate the aerial device if there is sufficient lighting at the job site to accomplish task safely.
13. Inspect controls before operation, do not operate the aerial device with malfunctioning controls.
14. Conduct a thorough pre-operation inspection of the machine and test all functions through their complete cycle before each work shift. Immediately tag and remove from service a damaged or malfunctioning machine.
15. Barricade or cover up any overhead electrical lines that have the potential for contact during operation.
16. Inspect and maintain personal protective equipment.
17. Perform inspections and maintenance as specified in the Maintenance Guidelines.
18. If this Aerial Device is equipped with platform tilt, an inspection must be made before entering the platform to insure all locks and pins are properly in place.
19. Operator's Manual must be on the vehicle available to the operator.





## DURING OPERATION

1. Never operate the Aerial Device unless you know the location, function, and operation of all the controls, including emergency and accessory operation.
2. Avoid abrupt starts, stops and reversal of direction. Operate all controls slowly for smooth motion.
3. Keep all parts of your body away from all moving parts to avoid injury.
4. Operator(s) must wear an OSHA approved fall arrest system with a lanyard attached to the anchor(s) provided.
5. Wear personal protective equipment such as: Insulated hard hat, rubber gloves with leather protectors, and rubber sleeves. Hearing and eye protection, proper boots and suitable clothing may also be required. Follow OSHA and employer’s policies for fire retardant (FR) clothing and arc flash protection.
6. Do not place the boom in open traffic lanes. Stop traffic or barricade lanes to divert traffic from area.
7. Do not allow boom, platform, or any part of the Aerial Device to contact fixed objects.
8. Do not tie off to an adjacent structure, pole, or other equipment.
9. Never exceed rated capacity of platform for men, tools, and liner if equipped.
10. Do not pass tools, equipment, or other objects between the occupant of the platform and other personnel on poles or other platforms.
11. Do not sit or climb onto edge of platform or use planks, ladders, or other devices for a work position. Always stand with both feet on the floor of the platform.
12. Do not wear climbers while in the platform.
13. Do not allow ground personnel under the platform work area.
14. Do not operate with platform leveling malfunctioning.
15. Do not move the vehicle with personnel in the platform.
16. This is not a material handling Aerial Device. The platform was designed for lifting personnel and tools within the platform capacity only.
17. Never tie loads to the platform or booms. This machine has no material handling capabilities. Never lift loads with the boom or platform.
18. This aerial device is not equipped with a lifting attachment and cannot be used to lift loads, branches or pull poles.
19. High speed should only be used when moving the platform to an aerial job site. Low speed should be used to move into, or within the aerial job site.
20. Low engine speed, if available, should be used when operating tools or maneuvering near obstructions such as trees, poles or lines.
21. If, when operating the Aerial Device, you become aware of any dangerous condition, unusual operation, or hear any unusual noise, such as grinding, cracking, or grating sounds-STOP-in position. Do not move the Aerial Device until the problem has been diagnosed and resolved with your safety in mind. No matter how long it may take to get help, waiting is better than a serious or fatal accident.
22. Do not adjust outriggers while booms are out of rest.
23. Do not operate boom controls while standing on the ground or other structures.



## ELECTRICAL HAZARDS

### ELECTRICITY OBEYS NO LAW, BUT ITS OWN.

1. Electricity is an ever-present danger when using an Aerial Device. Follow all OSHA, ANSI, state, federal and company rules and regulations when working on or near energized power lines.
2. Only perform work near or on electrical components according to your qualification. If not qualified, maintain minimum clearance distance according to OSHA and NESC and your employers safety policy.
3. Always maintain proper clearance from energized power lines. This Aerial Device cannot protect you from phase-to-phase or phase-to-ground contact occurring above the insulating boom section.
  - Allow for platform sag, sway or rocking.
  - If any part of the boom-tip, everything beyond band of arrows on boom, contacts an energized conductor, the controls handle(s) and the entire boom tip must be considered energized.
  - If any part of the boom-tip, everything beyond band of arrows on boom, contacts a grounded object, the controls handle(s) and the entire boom tip must be considered grounded.
4. The booms and operators shall be properly insulated from any contact with electrical conductors; including neutral or ground lines, poles, cross arms and guy wires. Utilize proper insulation such as line covers, rubber blankets and hot line tools.
5. All metal components at the boom tip beyond the band of arrows are interconnected. Contact of any part to an energized conductor will energize the entire boom tip, including the controls.
6. DO NOT contact energized conductors or operate your Aerial Device with missing or damaged covers or exposed metal fasteners. Even though covers are plastic or fiberglass, they are not tested or maintained for dielectric protection. Always cover conductors with line hose and maintain minimum approach distance from conductive items.
7. Never place booms, platforms, or personnel between energized conductors or between an energized conductor and a grounded conductor without proper cover up.
8. Wear proper clothing designed to reduce the extent of injury when exposed to flames or electric arcs. Follow your employer's policies for FR clothing.
9. Never operate the Aerial Device in an electrical environment unless the unit has been properly maintained with frequent and periodic inspections and a current annual dielectric test. When the fiberglass boom components are contaminated by moisture, dirt, or improperly maintained the dielectric protection will be compromised.
10. Never allow ground personnel to come in contact with the Aerial Device, vehicle, or vehicle attachments while in operation near energized power lines.
11. When working on or near energized power lines or equipment, the vehicle must be grounded and/or barricaded according to your employer's policies and considered energized.
12. Never rely on the fiberglass platform insulation for insulation. The platform may contain small unseen cracks that will allow an electrical path into the platform. Follow your employer's policies for use of a platform liner.
13. Never touch the controls or boom tip area when in the platform without using proper protection (wear insulated gloves with leather protectors) while contacting any conductors, neutrals, grounds, or other structures.
14. Ground and neutral conductors are current carrying conductors and must be treated as energized (wear rubber gloves with leather protectors).
15. Wear insulated gloves when handling duplex and triplex wires.
16. Do not increase the chance of accidental contact when working on or near energized structures or power lines, defeating the purpose of the liner:
  - All tools, accessories and other objects must be contained within the platform.
  - Do not attach any metal objects from outside the platform to the inside of the platform
  - Do not hang metal objects from the lip of the platform. This includes extension cords, guy wires or conductors.



# TEREX

17. Use only non-metallic tool holders and tool trays.
18. Check the boom tip area for any exposed conductive material and do not allow boom tip to come in contact with an energized phase or ground.
19. Do not carry or allow a conductor to touch your body. Handle conductors only with rubber gloves even if grounded.
20. Never use leather work gloves or bare hands on grounded conductors when energized conductors are on the same structure. Wear insulating rubber gloves with leather protectors.
21. Do not lift conductors with the boom tip or platform.
22. Do not operate boom controls while standing on the ground or other structure. Operating the machine while standing on the ground or other structure could result in electrocution.
23. Do not touch the truck or any attachments such as chippers or trailers when booms are elevated near energized power lines.



## ACCESSORIES

1. Only use hydraulic tools equipped with orange hoses marked NON-CONDUCTIVE. The hoses must be kept clean, dry and inspected before use.
2. All accessories must be inspected, maintained and operated with the same care and safety rules that apply to the Aerial Device.
3. Tools selected for use with this Aerial Device must be open-center and operate satisfactorily at 2250 PSI (15.51 MPa) and 5 GPM (19 LPM).
4. If this Aerial Device is equipped with platform tilt, an inspection must be made before entering the platform to insure all locks and pins are properly in place.
5. Do not place booms or platform under trees or limbs while trimming to avoid possible damage or overloading.
6. Operation of tools at high speed for extended periods will cause tools and the hydraulic system to overheat, damaging the tool and hydraulic system resulting in hose damage.
7. Do not use lower hydraulic tools or feed the chipper when platform or booms are near energized lines.



## TRAVELING

1. Never travel with personnel in the platform.
2. Never travel with the booms raised.
3. Store booms properly in the boom rest. Lower the lower boom fully before lowering upper boom into the rest.
4. Maintain boom rest for proper securement during travel. Repair as required.
5. Lock boom(s) in place with hold down system.
6. Secure all tools and items stored on the vehicle while traveling to prevent objects falling on the roadway.
7. Follow proper load securement procedures for loads on vehicle and trailers.
8. Fully retract the outriggers, store outrigger pads, and wheel chocks.
9. Disengage the power take-off to prevent damage.
10. Ensure platform liner is retained during travel with platform cover or clips to prevent loss.
11. Follow the vehicle manufacturer's instructions for operating the vehicle. All operators and passengers must at all times travel in seating positions designated by the vehicle manufacturer. They shall use seat belts and/or all other personal restraint systems provided.

**Drive Carefully!**



**MAINTENANCE**





1. Inspect, maintain, and repair the Aerial Device in accordance with this section and the maintenance manual for your Aerial Device.
2. Only knowledgeable, authorized and qualified personnel shall be allowed to perform maintenance on the Aerial Device.
3. Never drill holes in the platform.
4. Replace all missing or illegible decals.
5. Any changes or modifications to the Aerial Device must be approved by the manufacturer in writing.
6. Do not alter the insulated portion of the Aerial Device. Alterations may reduce the insulating value.
7. Do not search for hydraulic leaks with your hands or any other part of your body. Hydraulic fluid injection could occur requiring immediate medical attention.
8. All hoses must meet or exceed the working pressure of the Aerial Device.
9. Only use orange hoses marked NON-CONDUCTIVE for tool hoses, at the boom tip, and areas that bridge the insulation gap.
10. Do not use replacement components that are not equal to the original components.
11. Before doing any work on the hydraulic system, secure the booms and outriggers. Release any hydraulic pressure before attempting repairs or disassembly of hoses, valves, cylinders or any other hydraulic components.
12. Fuel or oil spills may require notification of appropriate Federal, State, or Local officials.
13. Do not operate the Aerial Device after adjustments or repairs until all guards and covers have been reinstalled, trapped air removed from the hydraulic system, safety devices reactivated, and maintenance equipment removed.
14. Inspect the unit following the frequent and periodic inspection intervals.
15. The subframe, outriggers, boom rest, and vehicle mounting must be inspected following the frequent and periodic inspection intervals for fastener tightness, damaged components and weld inspections.
16. Inspect, maintain, and operate the vehicle and components following the manufacturer's guidelines.
17. A post event inspection, testing, and documentation is required when the unit has been overloaded, shock loaded, overturned, in an accident, experienced electrical contact or any application of an unintended external force.







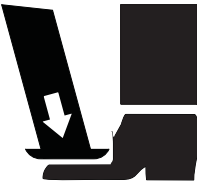

## OVERVIEW OF POTENTIAL HAZARDS AND SYMBOLS

The Aerial Device is a heavy moving machine capable of extending its reach vertically and horizontally. There are potential hazards associated with the use of this Aerial Device. These hazards will be minimized if the machine is properly inspected, maintained and operated. The operators shall read and understand this manual and be trained to use the machine in an appropriate and safe manner. Should any questions arise concerning the maintenance or operation of the machine contact Terex South Dakota, Inc..

SYMBOL	HAZARD	DESCRIPTION
Alert Symbol 	DANGER: Failure to follow will cause serious injury.	Your safety is involved.
Operators Manual 	DANGER: Failure to follow will cause serious injury.	Read and follow operator's manual for safe operation.
Maintenance Manual 	DANGER: Failure to follow will cause serious injury.	Follow all inspection and maintenance to prevent failure.
Electrical Contact 	DANGER: Will cause Serious Injury Maintain minimum clearance from or Death.	Maintain minimum clearance from overhead high voltage power lines. Refer to "Minimum Clearance for High Voltage Lines" chart in Appendix A. Maintain minimum approach distance as appropriate for your qualifications.  Do not dig near underground power lines.  Use machine only within its electrical rating. Consult the ID Placard for dielectric rating.
Unit Overturn 	WARNING: Can Cause Serious Injury or Death.	Do not travel on steep inclines or crosswise to grades. Do not travel on soft or unstable ground or close to unsupported excavations.  All tires must remain on the ground. Set outriggers (if equipped) so indicator remains in green area.
Crushing 	WARNING: Will Cause Serious Crushing Injury.	Do not operate outriggers unless you can verify all personnel and obstructions are clear. Operator must watch the outrigger while in motion.

<p>High Pressure Air or Fluid</p> 	<p><b>WARNING: Can Cause Serious Injury or Death.</b></p>	<p>Relieve pressure on hydraulic and pneumatic systems before loosening hoses or connections. Do not check for leaks with your hand.</p>
<p>Lanyard Attach.</p> 	<p><b>WARNING: Failure to Attach Can Cause Serious Injury or Death.</b></p>	<p>Attach lanyard to the anchor provided.</p>
<p>Lanyard Attach.</p> 	<p><b>WARNING: Failure to Attach Can Cause Serious Injury or Death.</b></p>	<p>Attach lanyard to the anchor provided.</p>
<p>Fall</p> 	<p><b>DANGER: Will cause Serious Injury or Death.</b></p>	<p>Always wear an OSHA approved fall arrest system with lanyard attached to anchor provided.</p>

# SAFETY RELATED DECALS

Safety decals are designed and applied on the Aerial Device and vehicle to warn of possible dangers, and MUST be replaced immediately if they are missing or illegible. If repairs are performed and parts have been replaced that had safety decals or labels applied, be sure new safety decals and labels are applied before the Aerial Device is put into service.

Use mild soap and water to clean safety decals - DO NOT use solvent based cleaners, as they may damage the safety decal material.



**Operating this equipment without all safety and control decals in place can be hazardous.**

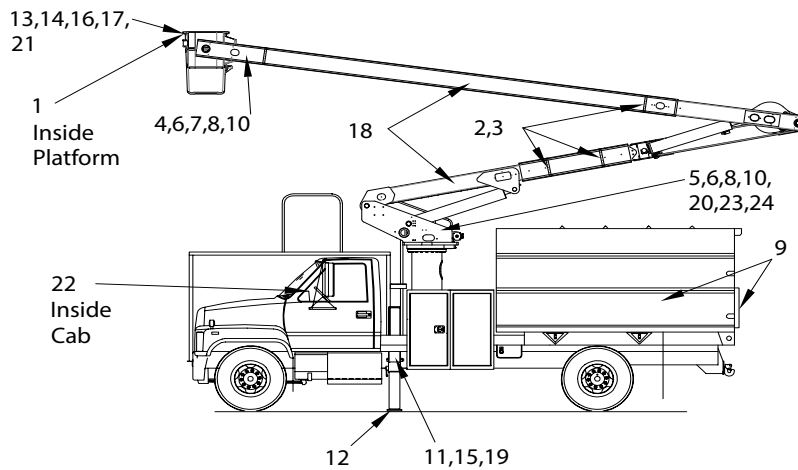

**NOTE: \*Use decal 419265 and 465703 when Aerial Device is not certified in accordance with latest ANSI A92.2 revision or booms are not insulated.**

**NOTE: \*\*Use 612455 for platform tilt with controls mounted between boom and platform.**

ITEM #	DECALS	QTY	PART #
1.	PLATFORM NOT INSULATED	1	47988
2.	ARROWS	13'	H21503
3.	NOT INSULATED BEYOND ARROWS	8	402236
4.	READ CAREFULLY	2	414590
5.	FAILURE TO OBEY	1	419262
6.	ELECTROCUTION HAZARD	3	419263
7.	FALLING FROM PLATFORM	2	419264
8. *	ELECTROCUTION HAZARD - NOT INSULATED	3	419265
9.	ELECTROCUTION HAZARD - KEEP CLEAR	3	419266
10.	UNTRAINED OPERATOR	3	419267
11.	OUTRIGGER - CRUSHING - DO NOT OPERATE	2	419268
12.	OUTRIGGER - CRUSHING - STAND CLEAR	2	419269
13.	CONDUCTIVE HOSE	2	419270
14. **	PLATFORM DUMP PIN AND RETAINER (OPTIONAL)	1	612455
15.	OVERTURNING HAZARD	2	458696
16.	SLOPE INDICATOR	2	486277
17.	CONTROLS NOT INSULATED	1	463602



18.	*	NOT INSULATED	4	465703
19.		ANSI WARNING	1	468476
20.		MAINTENANCE RECORD	1	489119
21.		LANYARD ATTACHMENT, X1	1	495441
22.		TRUCK COMPUTER	1	495845
23.		FALL HAZARD - MAINTENANCE	1	495892
24.		ESCAPING FLUID UNDER PRESSURE	1	H23877

1.

**THIS BASKET, WITHOUT AN INSULATING LINER, IS NOT CERTIFIED AS AN ELECTRICAL INSULATING BARRIER.**

47988D

2. & 3.

**DANGER**

**BOOM IS NOT INSULATED BEYOND ARROWS**

**AVOID CONTACT WITH ENERGIZED LINES.**

402236A

4.

**DANGER**

**READ CAREFULLY**

- OCCUPANTS OF THE BASKETS OF THIS AERIAL DEVICE HAVE ABSOLUTELY NO ELECTRICAL PROTECTION FROM CONTACT BY THE HUMAN BODY WITH TWO ENERGIZED CONDUCTORS OR BETWEEN AN ENERGIZED CONDUCTOR AND A GROUNDED CONDUCTOR.
- It makes no difference if this contact is accidental or deliberate or whether contact is made through metallic parts of the basket, basket support, metal tools or equipment brought into the basket. The insulating components of this aerial device do not offer protection in the event of such contact.
- Proper conductor cover up, insulated sleeves and gloves shall be worn when working near energized lines or equipment.

**DEATH OR SERIOUS INJURY WILL RESULT FROM SUCH CONTACT OR INADEQUATE CLEARANCE**

414590A

5.

**DANGER**

**FAILURE TO OBEY THE FOLLOWING WILL RESULT IN DEATH OR SERIOUS INJURY**

- For stationary operation, truck must be securely parked, driveline disengaged, and Aerial Device properly stabilized prior to operation.
- To avoid tip-over, outriggers (when so equipped) must be properly extended on a solid level surface.
- Operate all controls slowly for a smooth platform motion and make sure controls are returned to neutral after desired operation.
- Crew must use proper personal and other protective equipment.
- Never load beyond rated capacity.
- Never operate Aerial Device with personnel under boom or load.
- Never move the truck until the booms and outriggers are in a properly stowed position and secured.
- Refer to the operator's manual for complete instructions. If missing, replace manual.

419262

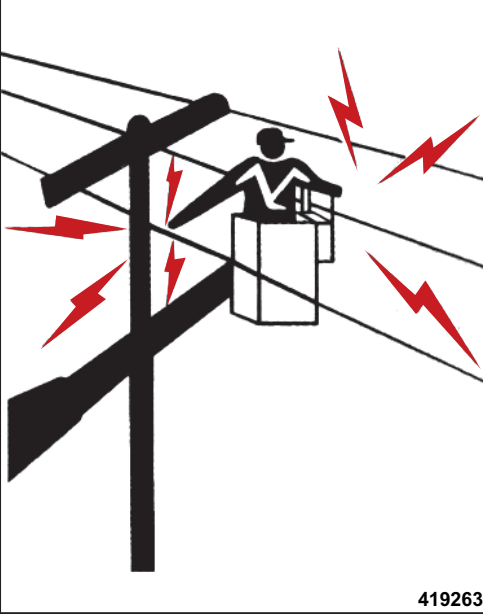

6.

<b>! DANGER</b>	
<b>ELECTROCUTION HAZARD</b> <b>DEATH OR SERIOUS INJURY WILL RESULT FROM CONTACT WITH OR INADEQUATE CLEARANCE TO ELECTRICAL POWER LINES AND APPARATUS</b> <ul style="list-style-type: none"><li>• Maintain safe clearances from electrical power lines in accordance with applicable government regulations. Allow for boom, platform, electrical line and load line sway.</li><li>• This machine does not provide protection from contact with or proximity to an electrically charged power line when you are in contact with or in proximity to another power line.</li></ul>	

419263

7.

<b>! DANGER</b>	
<b>FALLING FROM PLATFORM WILL RESULT IN DEATH OR SERIOUS INJURY</b> <ul style="list-style-type: none"><li>• Platform personnel must wear an OSHA approved fall protection system with lanyard attached to anchor provided.</li><li>• Platform doors, if provided, must be securely latched.</li></ul>	

419264A

8.

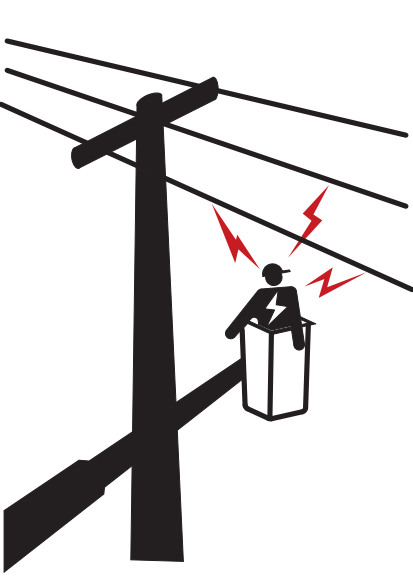
<p><b>! DANGER</b></p>	
<p><b>ELECTROCUTION HAZARD</b>  <b>THIS MACHINE IS NOT INSULATED</b>  <b>DEATH OR SERIOUS INJURY</b>                  Will result from contact with or inadequate clearance to electrical power lines and apparatus</p> <ul style="list-style-type: none"> <li>● Maintain safe clearance from electrical power lines in accordance with applicable government regulations. Allow for boom, platform, electrical line and load line sway.</li> <li>● This machine does not provide protection from contact with or proximity to an electrically charged power line.</li> <li>● Boom and platform must be kept below all electric power lines.</li> <li>● Do not use for work on electric power lines.</li> </ul>	
<p>419265A</p>	

9.

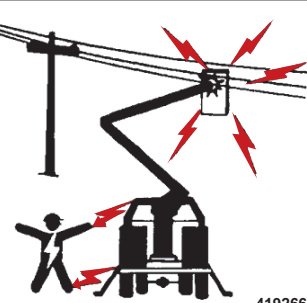
<p><b>! DANGER</b></p>	
<p><b>ELECTROCUTION HAZARD</b>                  DEATH OR SERIOUS INJURY                  WILL RESULT FROM CONTACT WITH THIS MACHINE, TRUCK OR TRUCK ATTACHMENTS IF THEY SHOULD BECOME ELECTRICALLY CHARGED.</p> <p><b>KEEP CLEAR OF TRUCK AND LOAD</b></p>	
<p>419266</p>	



10.

**! DANGER**

**AN UNTRAINED OPERATOR  
SUBJECTS HIMSELF AND  
OTHERS TO  
DEATH OR SERIOUS INJURY  
YOU MUST NOT OPERATE  
THIS MACHINE UNLESS**

- You have been trained in the safe operation of this machine.
- You have read, understand and follow the safety and operating recommendations contained in the machine manufacture's manuals, safety signs attached to equipment, your employer's work rules and applicable government regulations.
- You are sure the machine is operating properly and has been inspected and maintained in accordance with manufacturer's manuals.
- You are sure that all safety signs, guards and other safety features are in place and in proper condition.

419267

11.

**! DANGER**

**OUTRIGGER CONTACT  
WILL CAUSE  
SERIOUS CRUSHING INJURY**

- Do not operate any outrigger unless you or a signal person can see that personnel and obstructions are clear of the outrigger and its contact point.

419268A

12.

**! DANGER**



**OUTRIGGER CONTACT WILL CAUSE  
SERIOUS CRUSHING INJURY  
STAND CLEAR**

419269

13.

**! DANGER**

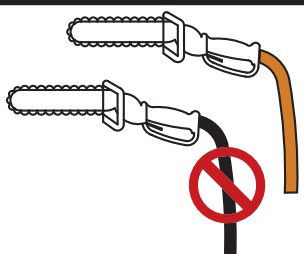

**ELECTROCUTION HAZARD  
FIRE HAZARD**

**USE ONLY ORANGE, NON-CONDUCTIVE  
HOSE FOR TOOL, PLATFORM AREA, AND  
INSULATED SECTIONS.**

**FAILURE TO DO SO MAY CAUSE  
DEATH OR SERIOUS INJURY.**

419270A



14.

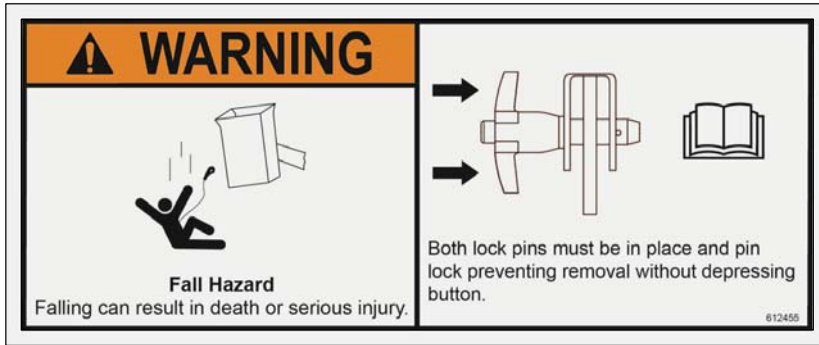

15.

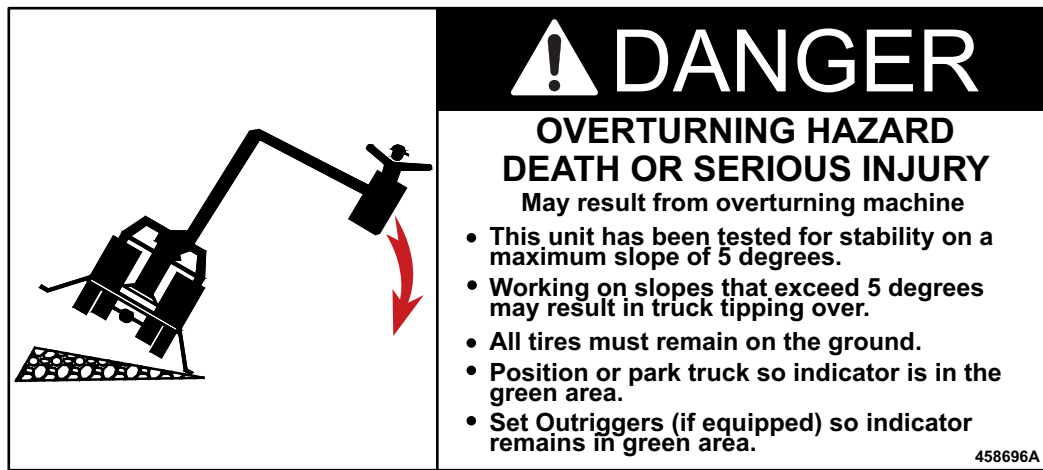

16.

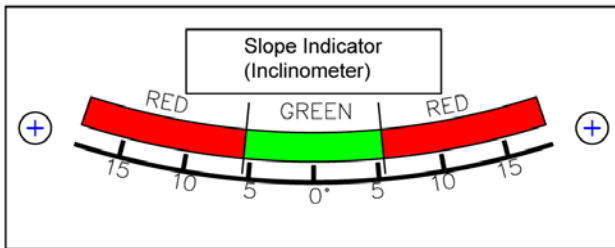







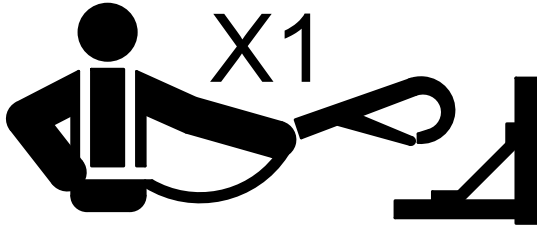

21.

495441





22.

 <b>WARNING</b>	
	<p style="text-align: center;"><b>CRUSHING HAZARD</b></p> <p>Changes to the vehicle computer settings could affect equipment operation and could result in crushing or tip over that could cause Death or Serious Injury.</p>
	<ul style="list-style-type: none"> <li>• Do not alter computer settings without full knowledge of affect of changes</li> <li>• See information supplied with truck manuals or contact final stage manufacturer for required settings</li> </ul> <p style="text-align: right; font-size: small;">495845</p>

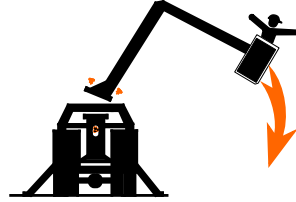

23.

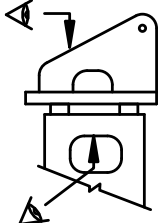
 <b>WARNING</b>	
 <b>FALL HAZARD</b> FAILURE TO PROPERLY MAINTAIN THIS MACHINE CAN LEAD TO STRUCTURAL FAILURE AND RESULT IN DEATH OR SERIOUS INJURY	
 	<p>Read and follow all inspection and maintenance schedules in the manual(s). Do not operate machine unless all deficiencies are corrected. Proper maintenance and inspection is required for safe and reliable operation.</p> <p>Daily Visual Inspection</p> <ul style="list-style-type: none"><li>- all structural components and welds</li><li>- all fasteners for damage, signs of looseness or missing from required location.</li><li>- damaged or missing covers or guards</li></ul> <p>Check torque on fasteners as required in manual(s). Fasteners include turntable to rotation bearing, pedestal to rotation bearing, cylinder and boom pivot pins and retainers, subframe mounting bolts and leveling components.</p> <p>The Aerial Device or Digger Derrick you are operating must be maintained by a qualified person.</p> <p style="text-align: right;">495892A</p>

24.

**! WARNING**



**Escaping fluid under pressure can penetrate skin causing serious injury.**

**Relieve pressure before disconnecting hydraulic lines. Keep away from leaks and pin holes. Use a piece of cardboard or paper to search for leaks. Do not use your hand.**

**Fluid injected into skin must be surgically removed within a few hours by a doctor familiar with this type injury or gangrene will result.**

H23877A



# WHAT IS INSULATED AND NOT INSULATED

## UPPER BOOM RATING

The ID plate on your aerial device will indicate if the unit is insulated and the voltage the insulation has been designed and tested to withstand. The manuals also indicate what areas of the machine will provide insulation. Look on the ID plate for the QUALIFICATION VOLTAGE. The number in this area is the voltage rating the unit was tested and qualified per ANSI standards. The date of the Manufacturing Qualification test is indicated on the ID plate as the TEST DATE.

**Not Insulated or Insulated**  
 If the Insulated box is checked, it indicates the booms will provide electrical insulation. If the Not Insulated box is checked, the unit will not provide any dielectric protection.

**Qualification Voltage**  
 Maximum Phase to Phase voltage machine can be used on with proper PPE and work procedures.

**ANSI Category**  
 Indicates what work unit is capable of performing.

**Date of Manufacturer Test**

ID PLATE

**WHAT IS INSULATED AND NOT INSULATED**



**WHAT IS INSULATED**

The following apply to insulated units only. If the unit is not equipped with an insulating boom the unit does not provide any electrical protection. Refer to the ID plate on the unit to determine if it is considered an insulating unit.

The term insulated means separated from other conductive surfaces by a dielectric substance (including air space) offering a high resistance to the passage of current (from OSHA 1926.960).

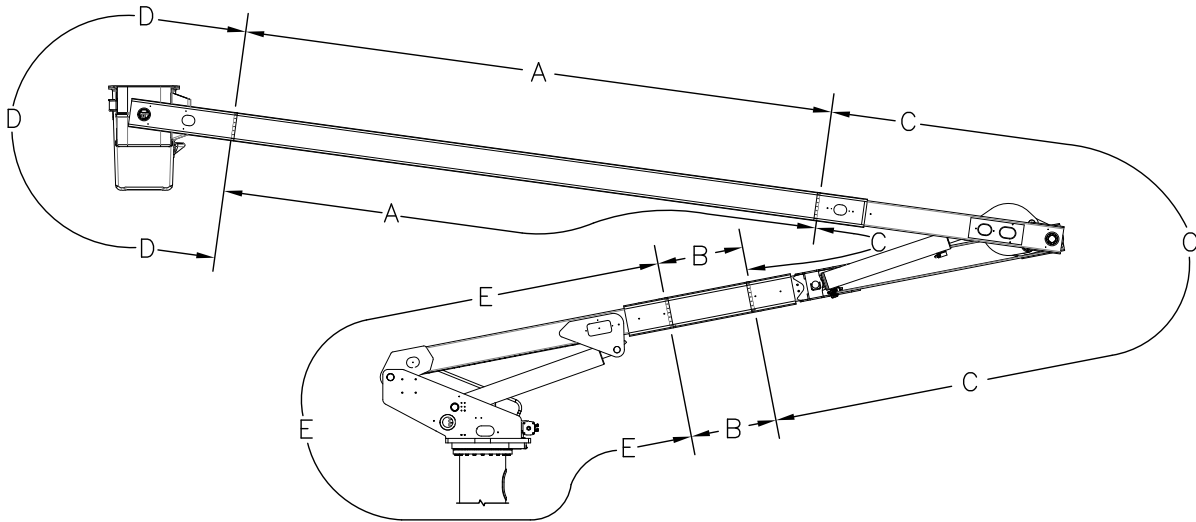

**Area A.** Upper Boom Insulation, provides an insulating area between area D and earth ground when in properly maintained condition.

**Area B.** Lower Boom Insert, provides an insulating area between area C and area E when in properly maintained condition.

**Area C.** Elbow, does not provide insulation. This area contains conductive materials such as cylinders, pins, boom structure, and other metal components. The operator shall not allow any portion of this area to come in contact with an energized phase, ground conductor, or grounded objects. Proper protective devices shall be used on all conductors. Any contact with a phase line, a ground and phase line or between two-phase conductors will create a hazard.





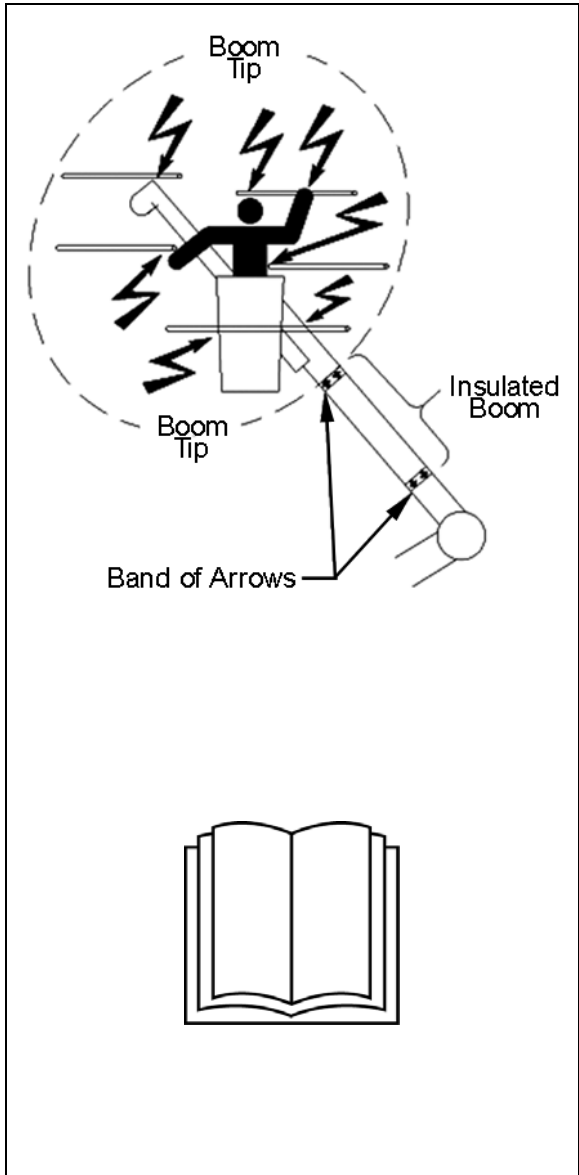

**Area D.** Boom Tip, does not provide insulation. This area contains conductive materials such as control levers, un-insulated platform(s), platform support shaft, boom-tip structure and other metal components. These objects must be considered connected. The operator shall not allow any portion of this area to come in contact with an energized phase, ground conductor or grounded objects. Proper protective devices shall be used on all conductors. The operator shall not make contact with any portion of this area when working on or near an energized phase, ground or grounded objects, unless wearing proper protective clothing such as rubber gloves and sleeves rated at the voltage of the lines. Any contact with a ground and phase or between two-phase conductors will create a hazard. Accidental contact of any portion of area D to an energized conductor will energize the entire area D. The jib and winch rope will be conductive if wet or dirty.

**NOTE: A properly maintained platform liner will only provide protection for those portions of the body or materials entirely within the liner and not in contact with any part of area D.**

**Area E.** Does not provide insulation. This area contains conductive materials such as cylinders, pins, boom structure, turntable, pedestal and other metal components. The operator shall not allow any portion of this area to come in contact with an energized phase, ground, or grounded objects. Proper protective devices shall be used on all conductors. This area is attached to the vehicle and connected trailers, which must be barricaded and/or grounded through an approved ground system when working in the vicinity of energized conductors. Any contact with a phase or between two-phase conductors will create a hazard.





-  The insulating boom section only prevents current from passing from the band of arrows at the boom tip to the lower band of arrows. All components above and below that area must be considered conductive.
-  The boom tip is everything past the upper band of arrows. All boom tip components are structurally and electrically connected. Contact with any part of the boom tip will energize the entire boom tip including, controls, jib, winch, and platform support structure.
-  Death or serious injury to the operator or ground personnel can occur if any part of the boom or boom tip contacts an energized conductor, ground line, grounded line, or OBJECTS. Proper clearance must be maintained.
-  You must always cover the line and wear proper PPE such as rubber gloves with rubber sleeves and an approved hard hat when any part of the Aerial Device is working on or near energized lines or conductors even when working on a grounded line, neutral line, or ground line.
-  Neutral, static and ground lines are current carrying conductors and require proper handling. Treat them as energized.
-  You must read the operators manual to fully understand the protection the Aerial Device will provide.

 **Anytime the platform occupant(s) contact two items at different potential without proper personnel protective equipment, their body may become a path for electric current, and they may be electrocuted. This includes touching the controls, any tools, or items on the boom tip while also contacting a line or ground.**

## ELECTRICAL INSULATION

Operation on or near energized lines is extremely hazardous unless proper OSHA and ANSI work rules are followed. The operation of this Aerial Device in proximity to high voltage electrical lines involves several hazards to the operator of the Aerial Device and any ground personnel. These hazards are as follows:

1. Contact of the operator with a single energized line will allow current to pass through the operator's body to ground by means of an all-metal boom structure, unless the operator is insulated from ground.
2. This Aerial Device will not provide protection to the operator from phase-to-phase or phase-to-neutral/ground contact at the boom tip, even if the operator is insulated from ground by the Aerial Device.



**The fiberglass upper boom, fiberglass lower boom insert and fiberglass platform, including its components, do not protect the platform operator from injury in case of contact between two energized lines, or between an energized line and a grounded conductor.**



**Working around electrical power lines is covered by ANSI and OSHA Regulations. To reduce danger to the operator and all ground personnel understand and follow all rules.**

**IMPORTANT: Only caution and proper work practice on the part of the occupant(s) will help protect the occupant(s).**

3. Contact of a metal section of the boom with a wire, below the insulation of the boom, will energize the Aerial Device and the vehicle causing electrocution to ground personnel and bystanders standing on the ground and touching the vehicle.



**Ground personnel should never touch the Aerial Device, chassis or an attached trailer while the Aerial Device is in operation near electrical power lines even though the Aerial Device has an insulated boom and lower boom insert.**



**Avoid contact of any metal part or equipment below the insulated section of the lower boom with an electrical power line. Serious injury or death could result.**

4. Contact of the boom with a conductor may break the conductor or burn the conductor in two, which will cause a hazard to any ground personnel below.

Some protection against Hazard No.1 is furnished by the fiberglass upper boom. When PROPERLY MAINTAINED, the insulated boom protects platform personnel in case they were to contact a SINGLE energized power line within the qualification voltage limit stamped on the ID placard. However, this protection can be nullified by accumulation of dirt and moisture on or in the boom. Insulating booms require frequent and periodic inspections and a current dielectric test.

Some protection against phase-to-phase or phase-to-neutral/ground contact, Hazard No. 2, is offered by the platform liner. The platform liner is used for phase-to-phase or phase-to-neutral/ground protection of the lower half of the body only. Only caution on the part of platform personnel and use of proper protective equipment will protect the upper half of their body from this hazard. Any conductive object in the platform liner, which protrudes above the liner, will eliminate any protection the liner may offer.

Limited protection of ground personnel against contact of the steel elbow area or lower boom with an energized conductor, Hazard No. 3, is offered by the insulated lower boom and a proper grounding system. The lower boom insert, like the insulated upper boom, must be regularly tested and cleaned to verify the dielectric integrity. Contact with an energized conductor below the lower boom insert will energize the chassis and the ground around the chassis. Anyone close to the chassis may be electrocuted. A ground cable to a suitable ground may provide some protection. Ground connections must make good contact with the chassis and a suitable ground rod, static or neutral. The ground cable must be completely unrolled and not lay over itself. A properly grounded vehicle does not guarantee protection for any ground personnel. Its purpose is to engage the line protection, fuse or breakers as quick as possible to limit damage. A lethal voltage may still exist between the chassis and ground.

There is no protection against Hazard No. 4. Caution must be exercised continually to avoid making contact with an energized conductor, which, if broken or burned, may drop to the ground and cause injury to any ground personnel.



**TEREX**



## PREVENTION OF ELECTROCUTION

1. NEVER rely on fiberglass dielectric properties around power lines with moisture present on the platform(s) and booms. If the Aerial Device is stored outdoors, protect the platform(s) and booms from the weather with a cover or perform periodic maintenance to prevent deterioration when not in use. To preserve dielectric properties, fiberglass must be kept clean and dry.
2. REMEMBER, auxiliary equipment, such as electrical cords, communication lines, and conductive tools, that bridge the insulation between the operator and ground, completely eliminating any insulation provided by the boom or platform liner.
3. REMEMBER your Aerial Device cannot protect you against contact between; two-phases, one phase and a pole, or one phase and a grounded conductor. Never work between energized conductors unless the proper precautions are performed to eliminate electrical contact.
4. DO NOT allow any ground personnel or bystanders to touch the Aerial Device, the chassis, or an attached trailer while the Aerial Device is in operation near energized conductors, even if the Aerial Device has an insulated lower boom.
5. The boom insulation must be dielectrically tested periodically in accordance with ANSI standards and your employer's policies.
6. CONTROLS are not insulated and are interconnected to all other conductive components at the boom tip. DO NOT contact any conductor while touching controls, unless wearing insulating rubber gloves rated for the voltage.
7. DO NOT depend on plastic covers, fiberglass covers, or guards installed on the Aerial Device for dielectric protection from contact with a line or ground. Although these components are plastic or fiberglass, they are not dielectrically tested and cannot be relied on to provide insulation. Hidden damage, dirt and contamination will make them conductive.

## OPERATION ON OR NEAR ENERGIZED CONDUCTOR

When working ON OR NEAR ENERGIZED CONDUCTORS (either known or suspected), additional work practices are required. While the fiberglass upper boom provides a high degree of electrical insulation between the platform and the vehicle, there are several things it WILL NOT DO:

- IT WILL NOT PROVIDE PHASE TO PHASE PROTECTION.
- IT WILL NOT PROVIDE PHASE TO GROUND PROTECTION THROUGH STATIC LINES OR GUY WIRES.
- IT WILL NOT PROTECT THE VEHICLE FROM BEING ENERGIZED IF CONTACT WITH ANY POWER SOURCE OCCURS BELOW THE INSULATION.

The fiberglass boom must be kept clean and dry, and have a current annual dielectric test to verify insulating properties.

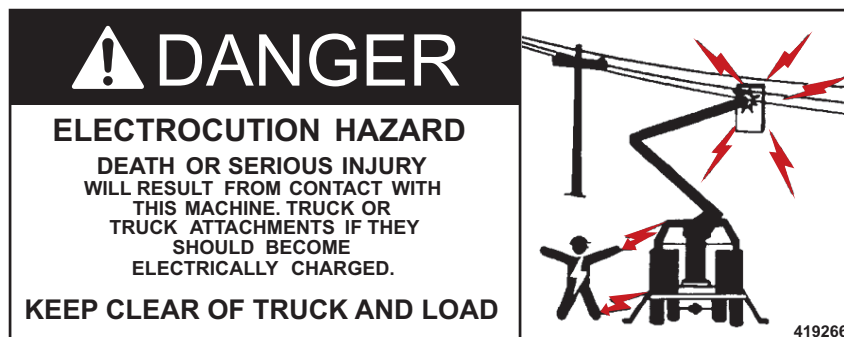



The fiberglass boom and platform liners must be dielectrically tested periodically to verify the insulating properties are maintained. Do not assume the unit offers insulating properties if it does not have a current annual dielectric test.



Ground personnel must stay away from chassis in case of accidental boom contact between conductor and metallic portion of boom, which will cause serious injury or death.



The fiberglass upper boom, fiberglass lower boom insert and fiberglass platform and liner, including its components, do not protect the platform operator from injury in case of contact between two energized lines or between an energized line and a grounded conductor.



Upper Controls can become energized if any part of the boom-tip past the band of arrows on the boom contacts a conductor. The Aerial Device upper control station has metal parts that are necessary to provide the structural support for the components. These metal parts at the boom-tip are interconnected. The main shaft that supports the platform(s) and controls also support other load carrying options that can be added to the boom-tip.



Do not depend on Aerial Device covers for insulation. Covers are not tested, certified or maintained as insulating.



All conductors including grounds and neutral lines are current carrying conductors and must be treated as energized unless properly grounded and tested.



The fiberglass upper and lower boom, in a well maintained condition, provides electrical insulation between the upper boom-tip and the vehicle to ground. This fiberglass will not protect the platform operator if any portion of the boom tip or upper control station, including options is brought into contact with an energized or non-energized conductor and the operator is in contact with a different potential, such as grounded non-energized conductor. This type of contact can energize or ground the controls because all components of the upper control station are interconnected. The fiberglass will not provide protection for the operator in phase to phase contact or a phase to ground wire contact above the upper boom insulation. Nor will it protect the vehicle from becoming energized if the steel boom section below the lower boom insert, if so equipped, is brought into contact with an energized conductor. Serious injury or death could result.

**! DANGER**

**READ CAREFULLY**

- OCCUPANTS OF THE BASKETS OF THIS AERIAL DEVICE HAVE ABSOLUTELY NO ELECTRICAL PROTECTION FROM CONTACT BY THE HUMAN BODY WITH TWO ENERGIZED CONDUCTORS OR BETWEEN AN ENERGIZED CONDUCTOR AND A GROUNDED CONDUCTOR.
- It makes no difference if this contact is accidental or deliberate or whether contact is made through metallic parts of the basket, basket support, metal tools or equipment brought into the basket. The insulating components of this aerial device do not offer protection in the event of such contact.
- Proper conductor cover up, insulated sleeves and gloves shall be worn when working near energized lines or equipment.

**DEATH OR SERIOUS INJURY WILL RESULT FROM SUCH CONTACT OR INADEQUATE CLEARANCE**

414590A

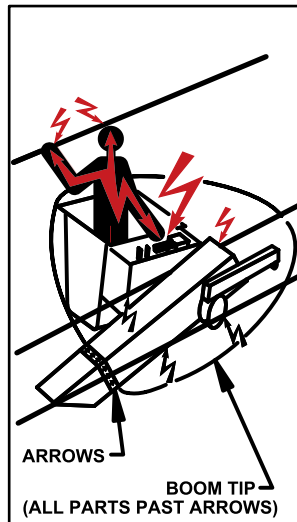

**! DANGER**

**ELECTROCUTION HAZARD**

**CONTROLS ARE NOT INSULATED OR ISOLATED**

All metal at boom tip is electrically connected. Operator contact with ANY, live or grounded, line or object while operator touches CONTROLS or BOOM TIP COMPONENTS and boom tip contacts any other line or object can result in

**DEATH OR SERIOUS INJURY**

Comply with OSHA, ANSI, & NESC requirements

- Maintain proper CLEARANCE to all lines and objects
- Wear Personal Protective Equipment: Fall protection; Eye protection; Insulating: gloves, sleeves, and hard hat; & Special clothing
- Cover all lines with insulated line hose or insulating blankets
- DO NOT Depend on machine covers for insulation. Plastic or fiberglass covers offer limited electrical insulation. Covers are NOT tested, certified, or maintained as insulating.

463602A



**WHAT IS INSULATED AND NOT INSULATED**



# SECTION 1

## OPERATION GUIDELINES

### NOMENCLATURE

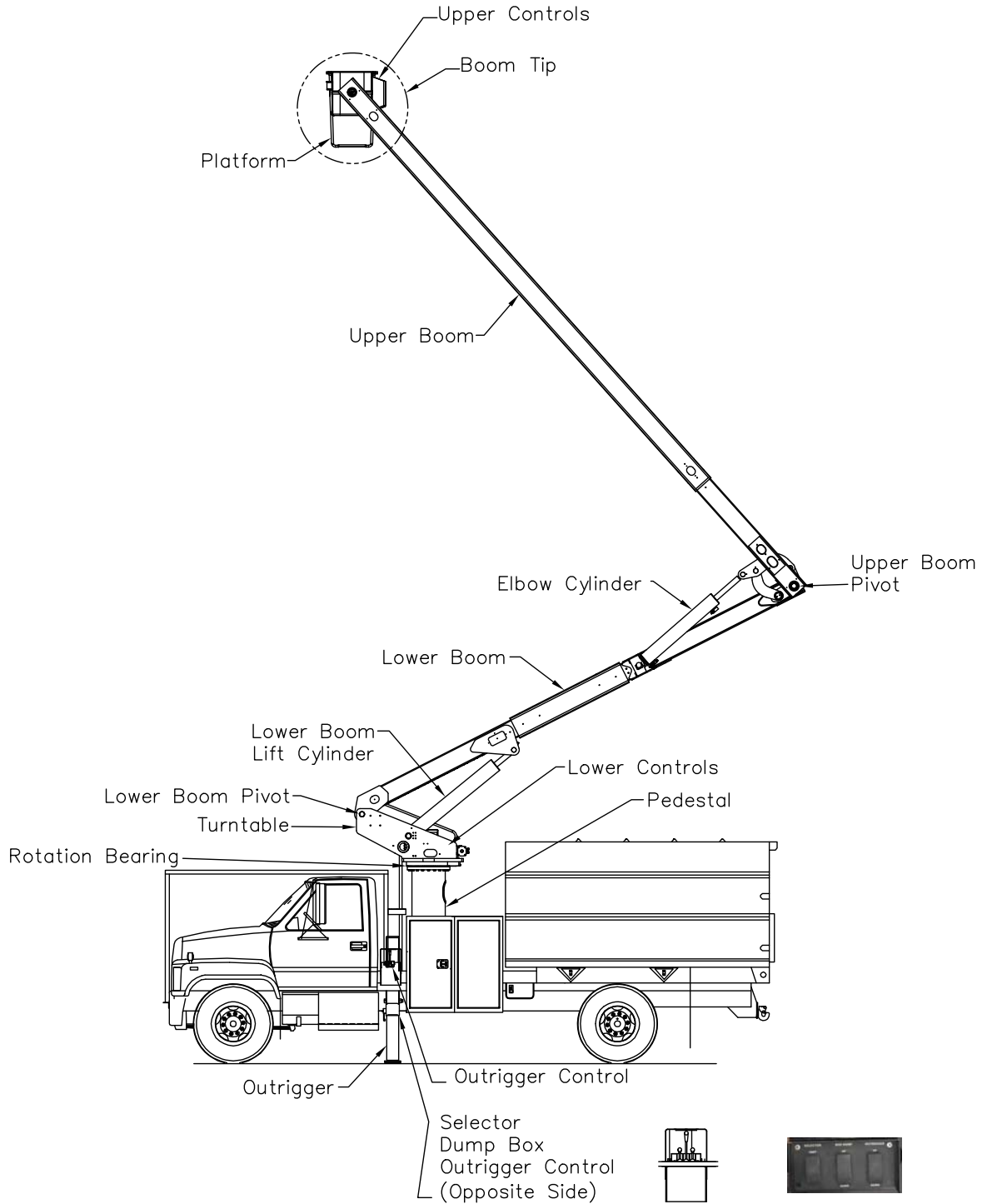

## CAB CONTROLS

### MASTER CONTROL

The master control (if equipped) is located in the cab of the vehicle. The master control may be located on the dash, the Terex Chassis Controller or switch panel. The master control is used to energize the engine stop/start system and the throttle control options, which may be located at the platform or on the tailshelf. When the light is lit, the switch is energizing these systems. The master switch may be incorporated with the PTO switch. If the unit is not equipped with the engine stop/start, two-speed throttle or 12V hydraulic power, it will not require a master control. It will have a means to activate the PTO.



CAB CONTROLS



**Be sure the vehicle transmission is in neutral and the brakes are applied before engaging the PTO or using the engine start/stop. Chock the wheels according to your company policies.**

### POWER TAKE-OFF (OPTIONAL)

The power take-off (PTO) is a gearbox used to transmit power from the vehicle transmission to the hydraulic pump, which provides hydraulic oil for the Aerial Device functions. The power take-off control can be a switch on the dash, the Terex Chassis Controller, switch panel or a “push-pull” knob (usually mounted on the cab floor) and a indicator light mounted in the vehicle dashboard. When lit, this indicator (PTO) dash light indicates the PTO is activated and serves to remind the operator not to drive the vehicle with the PTO engaged.



**Driving with the PTO engaged may damage both the pump and the PTO.**

To engage the power take-off properly, refer to the PTO manufacturer's operating instructions and be sure the manufacturer's operating decals are posted in the cab with the PTO controls.

**NOTE: Typical controls are illustrated. Each installation may be unique depending on configuration and options.**



**CAB CONTROLS OPERATION**

Master Power	See 1 (shown below)	<p>Push to activate the remote electrical systems. A light indicates when the system is active. This light may be separate or built into the switch panel or display.</p> <p>Push again to deactivate the remote electrical systems. The indicator light will turn off.</p> <p>Master Power may also be the PTO switch if a separate PTO switch is not installed.</p>
PTO	See 2 (shown below)	<p>Push to engage the PTO. A light indicates when the PTO is engaged. This light may be separate or built into the switch panel or display.</p> <p>Push again to deactivate the PTO. The indicator light will turn off when the PTO is disengaged.</p>
Warning Light	See 3 (shown below)	Controls vehicle warning light such as strobe lights.
Accessories switches	See 4 (shown below)	Optional accessories may be controlled by the remaining switches.



**CONTROLS BELOW ROTATION**

**FORESTRY VEHICLE**

These controls are usually mounted behind the vehicle cab. The controls may include outriggers, hydraulic tools, control selector, engine stop/start, and auxiliary let down power. The controls shown are generic. The actual location and functions will vary depending on the purchaser's requirements and options ordered. Control for the Chip box may be included in the outrigger valve or a separate valve depending on purchaser's requirements. Operation of the chip box requires the boom to be raised. Refer to the control decals on the unit for proper operation.

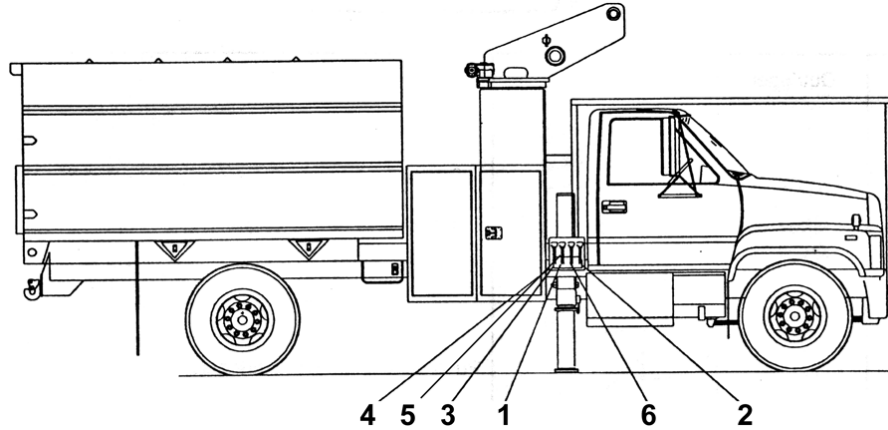

**FORESTRY VEHICLE CONTROL LOCATIONS.**

ITEM	CONTROL	DESCRIPTION
1.	Selector	A selector switch that allows operation of boom functions when in the "UP" position and operation of the outriggers when in the "DOWN" position.  <b>⚠ The Selector will function as an emergency stop by taking oil flow away from the active controls.</b>
2.	Outrigger Controls	Allows extending and retracting of outriggers.
3.	Hydraulic Tools (Optional)	Directs oil flow to the tool when connected to the quick couplers.
4.	Engine Stop/Start (Optional)	Allows operator to stop and start engine.
5.	Two Speed Throttle (Optional)  Auxiliary Let Down Power (Optional)	Two speed throttle provides two engine speeds, low and high, with engine running. Low speed is engine idle.  Auxiliary let down power provides hydraulic power to lower and stow the Aerial Device in the event of a prime power source failure.
6.	Chip Box Dump	Raises or lowers chip box.







**⚠ The decals are an integral part of this Aerial Device. If the decals are illegible, they must be replaced.**

**⚠ Meter controls for smooth operation when starting and stopping. Abrupt starting and stopping produces shock loading resulting in increased wear and possible damage to the aerial device.**

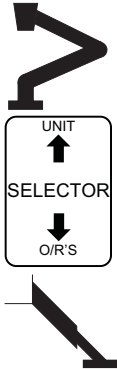

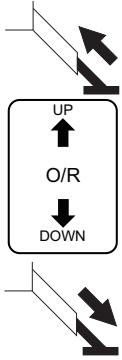

**CONTROLS BELOW ROTATION OPERATION**

1.	Selector		<p>Move switch up to activate "UNIT" system.</p> <p> <b>The Selector will function as an emergency stop by taking oil flow away from the active control.</b></p> <p>Move switch down to operate outrigger system "O/R'S".</p>
2.	Outrigger Controls		<p>Move switch "UP" to raise outrigger.</p> <p>Move switch "DOWN" to lower outrigger.</p>
3.	Hydraulic Tools (Optional)		<p>Return handle to center position to turn off.</p> <p>Turn tool "OFF" before operating other functions.</p> <p>Move handle to energize tool quick couplers pressure and return in direction required.</p>
4.	Engine Stop/Start (Optional)		<p>Push and hold to start engine. Release when engine starts.</p> <p>Push and release to stop engine.</p> <p> <b>Can also be used to stop the Aerial Device in an emergency.</b></p>
5.	Two Speed Throttle (Optional)  *Auxiliary Let Down Power (Optional)		<p>With engine running, the throttle is activated.</p> <p>Push and release to increase engine RPM.</p> <p>Push and release to return to engine idle.</p> <p>With engine "OFF", the auxiliary let down power is activated.</p> <p>Push and hold to turn on auxiliary let down power.</p> <p>Release to shut off auxiliary let down power.</p>
<p><b>NOTE: *Can be included with two-speed throttle circuit. When vehicle engine is disabled, the auxiliary let down power can be activated by the two-speed throttle switch.</b></p> <p><b>NOTE: *Do not operate longer than 30 seconds. Continuous operation will drain battery and/or overheat pump motor.</b></p>			

6.	Chip Box Dump		<p>Push switch "UP" to dump chip box.</p> <p><b>CAUTION: Always raise booms before dumping chip box to prevent damage to booms.</b> Booms must remain in line with the stored position. <b>DO NOT ROTATE.</b></p> <p>Push switch "DOWN" to store chip box.</p>
----	---------------	--	--

 **Do not rotate booms from stored position without outriggers properly set when dumping chip box.**

The Electric Outrigger Controls are located on the passenger side in the cab, on the bottom side of seat.



**CONTROL SELECTOR WITH BOX DUMP AND OUTRIGGER**

**UTILITY VEHICLE**

These controls are usually mounted at the rear of the vehicle chassis. The controls may include outriggers, hydraulic tools, control selector, engine stop/start, two-speed throttle, and auxiliary let down power. The controls shown are generic. The actual location and functions will vary depending on the purchasers requirements and options ordered. Refer to the control decals on unit for proper operation.

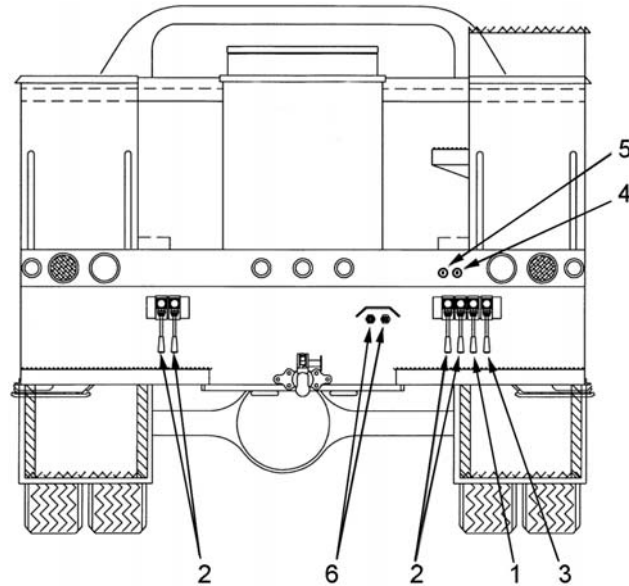

**UTILITY VEHICLE CONTROL LOCATIONS**







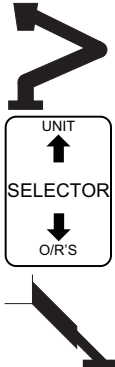

ITEM	CONTROL	DESCRIPTION
1.	Selector	A selector valve that allows operation of boom functions when in the "UP" position and operation of the outriggers when in the "DOWN" position.   <b>The Selector will function as an emergency stop by taking oil flow away from the active controls.</b>
2.	Outrigger Controls	Allows extending and retracting of outriggers.
3.	Hydraulic Tools (Optional)	Directs oil flow to the tool when connected to the quick couplers.
4.	Engine Stop/Start (Optional)	Allows operator to stop and start engine.
5.	Two-Speed Throttle (Optional)	Two-speed throttle provides two engine speeds, low and high, with engine running. Low speed is engine idle.
	Auxiliary Let Down Power (Optional)	Auxiliary let down power provides hydraulic power to lower and stow the Aerial Device in the event of a prime power source failure.
6.	Hydraulic tool couplers (Optional)	Quick couplers for hydraulic tool connection.

 **The decals are an integral part of this Aerial Device. If the decals are illegible, they must be replaced.**

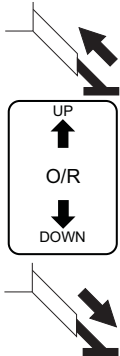
 **Meter controls for smooth operation when starting and stopping. Abrupt starting and stopping produces shock loading resulting in increased wear and possible damage to the aerial device.**

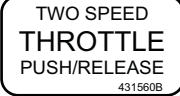

**CONTROLS BELOW ROTATION OPERATION**

1.	Selector		<p>Move handle up to activate "UNIT" system.</p> <p> <b>The Selector will function as an emergency stop by taking oil flow away from the active control.</b></p> <p>Move handle down to operate outrigger system "O/R'S".</p>
2.	Outrigger Controls		<p>Move handle "UP" to raise outrigger.</p> <p>Move handle "DOWN" to lower outrigger.</p>
3.	Hydraulic Tools (Optional)		<p>Return handle to center position to turn off.</p> <p><b>NOTE: Turn tool "OFF" before operating other functions.</b></p> <p>Move handle to energize tool quick couplers in direction required. "ON" direction energizes male coupler.</p>
4.	Engine Stop/Start (Optional)		<p>Push and hold to start engine. Release when engine starts.</p> <p>Push and release to stop engine.</p> <p> <b>Can also be used to stop the Aerial Device in an emergency.</b></p>
5.	<p>Two-Speed Throttle (Optional)</p> <p>*Auxiliary Let Down Power (Optional)</p>	 	<p>With engine running, the throttle is activated.</p> <p>Push and release to increase engine RPM.</p> <p>Push and release to return to engine idle.</p> <p>With engine "OFF", the auxiliary let down power is activated.</p> <p>Push and hold to turn on auxiliary let down power.</p> <p>Release to shut off auxiliary let down power.</p>
<p><b>NOTE: *Can be included with two-speed throttle circuit. When vehicle engine is disabled, the auxiliary let down power can be activated by the two-speed throttle switch.</b></p> <p><b>NOTE: *Do not operate longer than 30 seconds. Continuous operation will drain battery and/or overheat pump motor.</b></p>			

## OPERATOR CONTROLS AND DESCRIPTIONS

Aerial Device functions may be controlled from either the upper controls at the platform or the lower controls station. The platform controls are used, in normal operation, by the operator to control the Aerial Device. The lower controls are used for inspection, maintenance, and in emergency situations. The Control Selector at the lower controls determines which control station is operable. Only one is operable at any time.

The upper controls may be a single stick control. The single stick control has one lever that controls all boom functions. The single stick has an enable lever that must be squeezed to allow operation of the boom functions. Center the single stick in the neutral position before depressing the enable lever. Always return the single stick to the centered or neutral position before releasing the enable lever. If the enable lever is depressed while the single stick is not in neutral the function will begin moving suddenly. If the enable lever is released before the single stick is returned to neutral the movement will be unpredictable. The actual controls on an Aerial Device will depend on the options it is equipped with.

Controls provide proportional metering of the function, meaning the distance the control lever is moved determines the speed. The farther the lever is moved from the neutral or center position, the faster the function will operate.

While becoming familiar with the operation of the Aerial Device, do not operate functions at full speed. First, operate each function separately. Then operate two or more functions together. Learn to move the platform in an arc to any desired position within reach of the platform. Operate the functions with smooth, gradual, starts and stops. Use full speed when in clear areas with no obstructions and slow speeds when approaching objects, the ground or chassis. Smooth operation will get you to your work area quicker and more comfortably, with less wear and tear on the equipment. Anticipate the time it takes to stop, and begin slowing down beforehand, to stop without overshooting.

Single stick controls are high resistance controls and require inspection and periodic testing. The high resistance controls are not rated and are not part of the insulating system that enables the aerial device to have an insulating rating.



**The high resistance single stick control does not provide protection in the event of electrical contact and is not a substitute for maintaining minimum approach distance, cover up, rubber gloves, and other personal protective equipment.**

 **DANGER**

### ELECTROCUTION HAZARD

**CONTROLS ARE NOT INSULATED OR ISOLATED**

All metal at boom tip is electrically connected.  
 Operator contact with ANY, live or grounded, line or object while operator touches **CONTROLS** or **BOOM TIP COMPONENTS** and boom tip contacts any other line or object can result in

**DEATH OR SERIOUS INJURY**

Comply with OSHA, ANSI, & NESC requirements

- Maintain proper **CLEARANCE** to all lines and objects
- Wear Personal Protective Equipment: Fall protection; Eye protection; Insulating: gloves, sleeves, and hard hat; & Special clothing
- Cover all lines with insulated line hose or insulating blankets
- **DO NOT** Depend on machine covers for insulation

Plastic or fiberglass covers offer limited electrical insulation. Covers are **NOT** tested, certified, or maintained as insulating. 463602A





**Only the platform operator controls the Aerial Device during normal operation. Never operate the Aerial Device from the ground control with someone in the platform, except in an emergency situation.**



**LIFT LOCK HANDLES**

If a control lever at the upper controls operates boom movement, other than in the single stick, the control will have a lift lock handle.

A spring-loaded lever on each boom function lever locks the levers in a neutral position and prevents accidental actuation. A control lever placard indicates the direction to move the control lever to activate a specific boom movement. To activate a boom movement the handle must be pulled "up" and held, so the control lever can operate the desired boom function. When the handle is released the spring pulls the handle "down" to a neutral position and locks the control lever in that position.

**UPPER CONTROLS**

**SINGLE STICK**

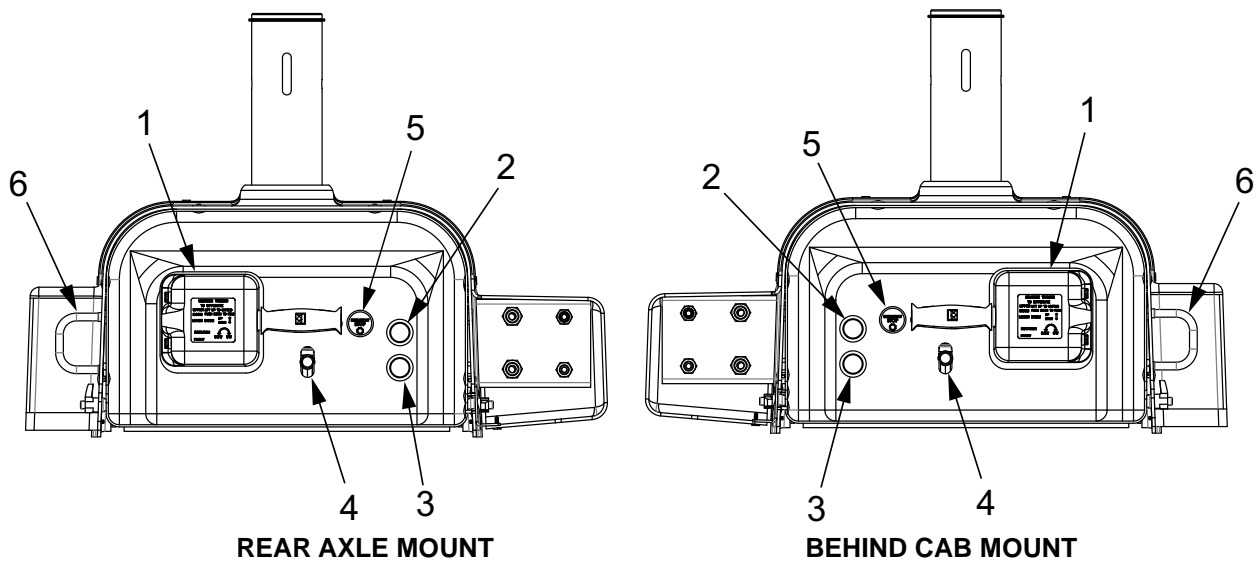

ITEM	CONTROL	DESCRIPTION
1.	Single Stick	Controls upper boom, lower boom, and rotation.
2.	Engine Stop/Start (Optional)	Allows the operator to stop and start the engine from the platform.
3.	Two-Speed Throttle  Auxiliary Let Down Power (Optional)	Two-speed throttle provides two engine speeds, low and high, with engine running. Low speed is engine idle.  Auxiliary let down power provides hydraulic power to lower and stow the Aerial Device in the event of a prime power source failure.
4.	Hydraulic Tools (Optional)	Controls oil flow to hydraulic tools.
5.	Emergency Stop	Diverts the oil to the tank to stop all operation of platform controls.
6.	Lanyard Attachment	Approved connection point for lanyard.

 **The decals are an integral part of this Aerial Device. If the decals are illegible, they must be replaced.**

 **Meter controls for smooth operation when starting or stopping. Abrupt starting and stopping produces shock loading resulting in increased wear and possible damage to the aerial device.**



**UPPER CONTROL OPERATION**

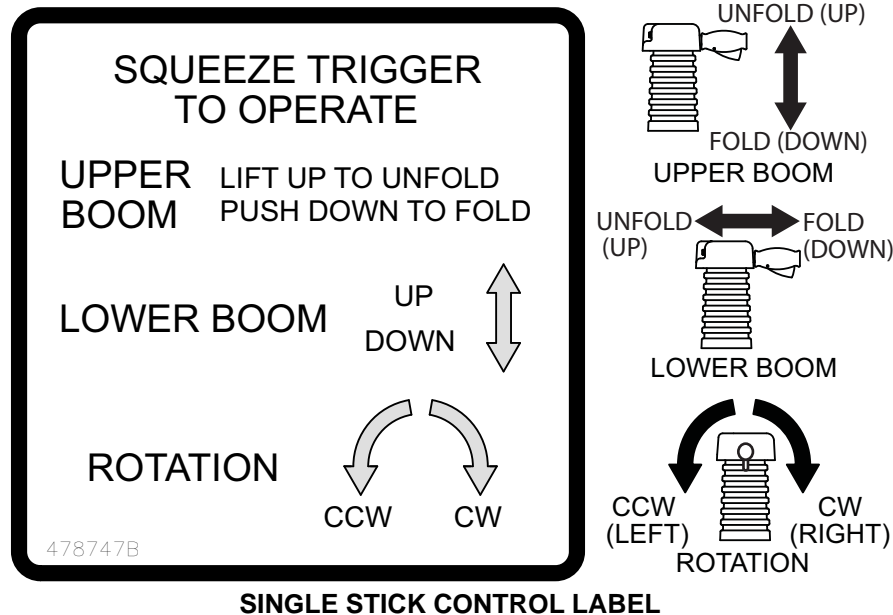

The control location shown is generic. The actual location will vary depending on purchasers requirements and options. Some of the following control functions may not be included in the controls for this Aerial Device. Refer to the control decals on unit for proper operation.



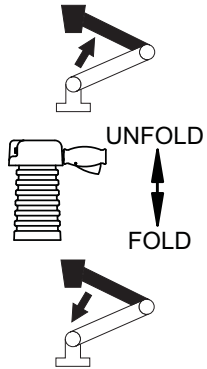
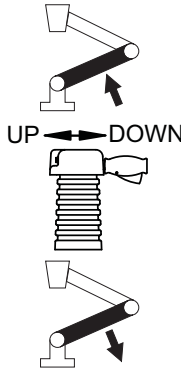
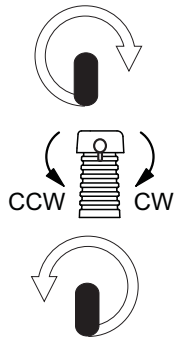

**!** Be sure the control handle is in the centered neutral position before depressing enabling lever. Return the control handle to centered neutral position before releasing the enabling lever. Failure to follow these procedures will cause sudden or unexpected movement of the platform that may result in serious injury or death.

**!** The Aerial Device upper control station has interconnected metallic parts, which are necessary to provide the structural support for the various components. The main shaft that supports the platform and controls must also support other load carrying options that can be added to the boom tip.

The fiberglass upper and lower boom, in a well maintained condition, provides electrical insulation between the boom tip and the truck as a potential to ground. This fiberglass will not protect the operator in the platform if any portion of the boom tip, including options, is brought into contact with an energized or non-energized conductor and the operator is in contact with a different potential, such as, a grounded non-energized conductor. This type of contact can energize or ground the controls because as stated before, all components of the boom tip are interconnected. The fiberglass will not provide protection for the operator in phase to phase contact or a phase to ground contact, nor will it protect the vehicle from becoming energized if the steel boom section below the lower boom insert, if so equipped, is brought into contact with an energized conductor.

1.	Upper Boom		<p>Squeeze the trigger and lift lever up to “UNFOLD” upper boom.</p> <p>Squeeze the trigger and push lever down to “FOLD” upper boom.</p>
	Lower Boom		<p>Squeeze the trigger and push lever forward to unfold the lower boom “UP”.</p> <p>Squeeze trigger and pull lever back to fold the lower boom “DOWN”.</p>
	Boom Rotation		<p>Squeeze the trigger and twist lever right to rotate booms clockwise “CW”.</p> <p>Squeeze the trigger and twist lever left to rotate booms counterclockwise “CCW”.</p>
2.	Engine Stop/Start (Optional)		<p>Push and hold to start engine. Release when engine starts.</p> <p>Push and release to stop engine.</p> <p> <b>Can also be used to stop the Aerial Device in an emergency.</b></p>

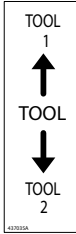

3.	<p>Two-Speed Throttle</p> <p>*Auxiliary Let Down Power (Optional)</p>	 <p>TWO SPEED THROTTLE PUSH/RELEASE 431560B</p> <p>DC POWER PUSH/HOLD 457452</p>	<p>With engine running, the throttle is activated. Push and release to increase engine RPM. Push and release to return to engine idle.</p> <p>With engine "OFF", the auxiliary let down power is activated. Push and hold to turn on auxiliary let down power. Release to shut off auxiliary let down power.</p>
<p><b>NOTE: *Can be included with two-speed throttle circuit. When vehicle engine is disabled, the auxiliary let down power can be activated by the two-speed throttle switch.</b></p> <p><b>NOTE: *Do not operate longer than 30 seconds. Continuous operation will drain battery and/or overheat pump motor.</b></p>			
4.	<p>Hydraulic Tools (Optional)</p>	 <p>TOOL 1 ↑ TOOL ↓ TOOL 2 43203A</p>	<p>Push to select tool circuit number 1.</p> <p>Pull to select tool circuit number 2, if equipped.</p>
5.	<p>Emergency Stop</p>	 <p>EMERGENCY STOP</p>	<p>Push to stop all operations at the platform controls. This diverts all oil to the tank.</p> <p>Pull to resume operation.</p>

**INDIVIDUAL LEVER**

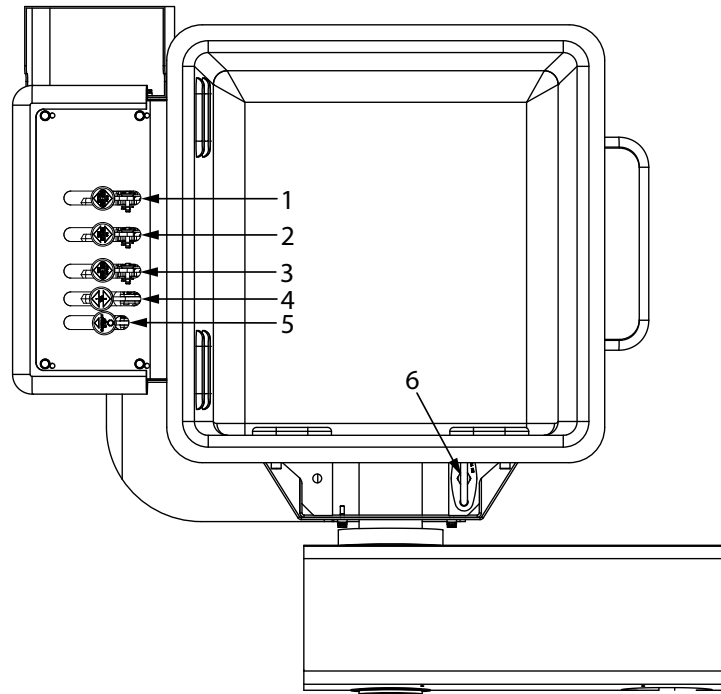

ITEM	CONTROL	DESCRIPTION
1.	Lower Boom	Controls lower boom lift.
2.	Boom Rotation	Controls rotation of the booms.
3.	Upper Boom	Controls upper boom lift.
4.	Hydraulic Tools (Optional)	Controls oil flow to hydraulic tools.
5.	Stop	Diverts the oil to the tank to stop all operation of platform controls.
6.	Lanyard Attachment	

**NOTE: To activate boom movement (1, 2, and 3), the handle must be pulled UP and held UP while operating the desired function. (Refer to operational decals on the Aerial Device.)**







The decals are an integral part of this Aerial Device. If the decals are illegible, they must be replaced.



Meter controls for smooth operation when starting and stopping. Abrupt starting and stopping produces shock loading resulting in increased wear and possible damage to the aerial device.

**INDIVIDUAL LEVER FUNCTIONS**

1.	Lower Boom		<p>Pull up on lever and push to "FOLD" lower boom.</p> <p>Pull up on lever and pull to "UNFOLD" lower boom.</p>
2.	Boom Rotation		<p>Pull up lever and push to rotate booms clockwise "CW".</p> <p>Pull up lever and pull to rotate booms counterclockwise "CCW".</p>
3.	Upper Boom		<p>Pull up on lever and push to "FOLD" upper boom.</p> <p>Pull up on lever and pull to "UNFOLD" upper boom.</p>

4.	Hydraulic Tools (Optional)	 <p>A circular button with a diamond shape inside. The top half of the diamond contains the number '1' and the bottom half contains the number '2'. The word 'TOOL' is written across the center of the diamond.</p>	<p>Push to select tool circuit number 1.</p> <p>Turn tool "OFF" before operating other functions.</p> <p>Pull to select tool circuit number 2, if equipped.</p>
5.	Stop	 <p>A circular button with a triangle at the top and a hexagon at the bottom. The text 'EMERGENCY STOP' is written in the center.</p>	<p>Push to stop all operations at the platform controls. This diverts all oil to the tank.</p> <p>Pull to resume operation.</p>

**LOWER CONTROLS  
BEHIND CAB MOUNT**

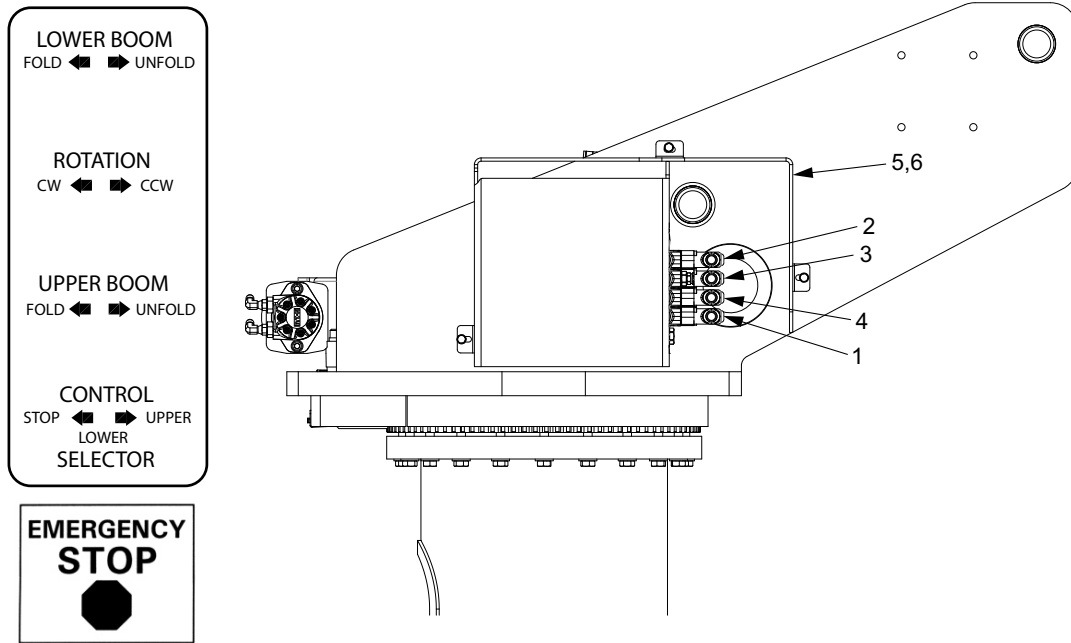

ITEM	CONTROL	DESCRIPTION
1.	Control Selector 	Selects platform, lower control operation or stop. <b>! The Control Selector will function as an emergency stop.</b>
2.	Lower Boom	Controls lower boom lift.
3.	Boom Rotation	Controls rotation of the booms.
4.	Upper Boom	Controls upper boom lift.
5.	Engine Stop/Start (Optional)	Controls stop and start of the engine from the pedestal.
6.	Two-Speed Throttle (Optional Location)  Auxiliary Let Down Power (Optional)	Two-speed throttle provides two engine speeds, low and high, with engine running. Low speed is engine idle.  Auxiliary let down power provides hydraulic power to lower and stow the Aerial Device in the event of a prime power source failure.

**NOTE: Lower boom, upper boom, and rotation sequence may vary. Refer to decal on Aerial Device.**

**! The decals are an integral part of this Aerial Device. If the decals are illegible, they must be replaced.**

**! Meter controls for smooth operation when starting and stopping. Abrupt starting and stopping produces shock loading resulting in increased wear and possible damage to the aerial device.**



**REAR AXLE MOUNT**

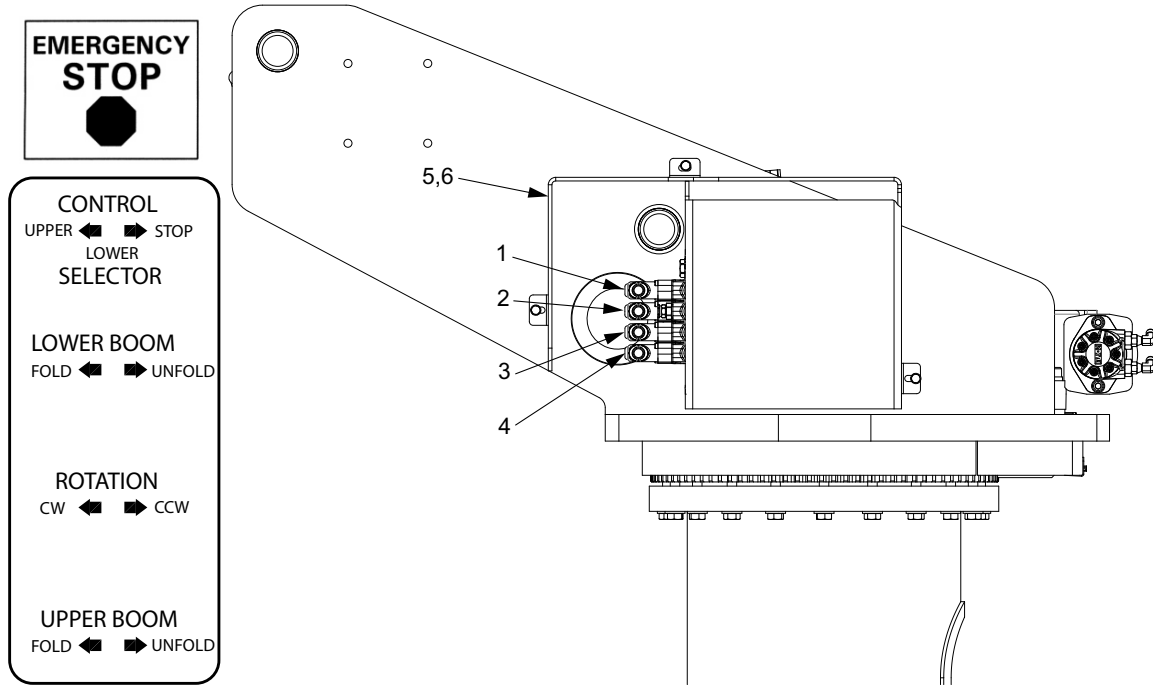

ITEM	CONTROL	DESCRIPTION
1.	Control Selector 	Selects platform, lower control operation or stop.  <b>⚠ The Control Selector will function as an emergency stop.</b>
2.	Lower Boom	Controls lower boom lift.
3.	Boom Rotation	Controls rotation of the booms.
4.	Upper Boom	Controls upper boom lift.
5.	Engine Stop/Start (Optional)	Controls stop and start of the engine from the pedestal.
6.	Two-Speed Throttle (Optional Location)  Auxiliary Let Down Power (Optional)	Two-speed throttle provides two engine speeds, low and high, with engine running. Low speed is engine idle.  Auxiliary let down power provides hydraulic power to lower and stow the Aerial Device in the event of a prime power source failure.

**NOTE: Lower boom, upper boom and rotation sequence may vary. Refer to decal on Aerial Device.**

**⚠ The decals are an integral part of this Aerial Device. If the decals are illegible, they must be replaced.**

**⚠ Meter controls for smooth operation when starting and stopping. Abrupt starting and stopping produces shock loading resulting in increased wear and possible damage to the aerial device.**



### CONTROL SELECTOR

The control selector lever is used to select which controls will be operating, platform, lower controls or none. The selector will detent to the UPPER position for platform operation. It is spring loaded to move to the STOP position when not selected to UPPER. In the STOP position neither the lower or upper controls will operate. The lower controls may override the upper controls in case of an emergency by operating lower controls, provided the hydraulic system is intact.

The upper controls are not operable when the STOP or LOWER positions are selected and the lower controls are not operable when the UPPER controls are selected.



**Use control selector to override upper controls. The lower control position stops oil flow to the upper controls at the boom tip.**

### LOWER CONTROL OPERATION

The control location shown is generic. The actual location will vary depending on the purchaser requirements and options. Some of the following control functions may not be included in the controls for this Aerial Device. Refer to the control decals on unit for proper operation.

To operate the lower controls the Control Selector lever must be moved and held in the LOWER, (middle position), while also operating the desired function lever. When released the selector lever will return to the STOP position. The remaining control levers are self-centering, spring-loaded, and return to the neutral position when released. The controls are proportional. The farther they are moved the faster the function will operate. Feather the controls for smooth starts and stops.

The following are mounted on the side of the turntable.

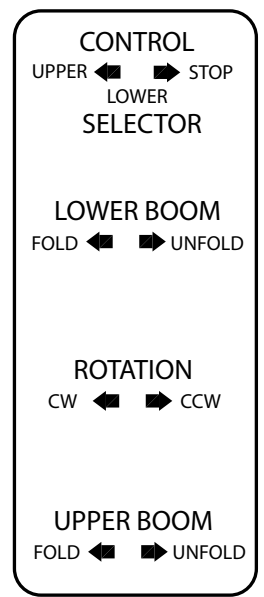

REAR AXLE MOUNT

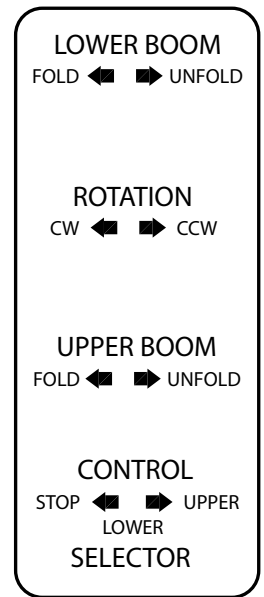







BEHIND CAB MOUNT

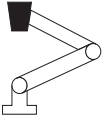
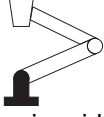
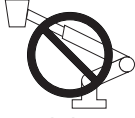

**Keep the truck bed area free of obstructions to avoid interference with the lower controls and personnel who may have to operate the lower controls in an emergency.**

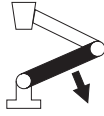
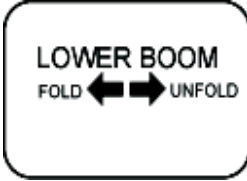
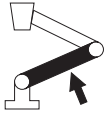

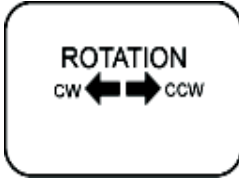
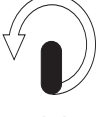
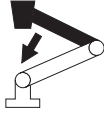
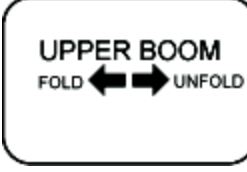



**Do not operate lower controls while standing on ground or other structure with booms elevated from stored position. Operating the machine while standing on the ground or other structure could result in electrocution.**

1.	<p>Control Selector</p> 	 <p>Push lever left to select "UPPER" controls.</p>	<p>CONTROL UPPER ← → STOP LOWER SELECTOR</p>  <p>Hold lever in middle to operate "LOWER" controls.</p>	 <p>Pull lever right to stop operation of both controls.</p>
<p> <b>The Control Selector will function as an emergency stop.</b></p>				
2.	<p>Lower Boom</p>	 <p>Push lever left to "FOLD" lower boom.</p>		 <p>Pull lever right to "UNFOLD" lower boom.</p>
3.	<p>Boom Rotation</p>	 <p>Push lever left to rotate clockwise "CW".</p>		 <p>Pull lever right to rotate counterclockwise "CCW".</p>
4.	<p>Upper Boom</p>	 <p>Push lever left to "FOLD" upper boom.</p>		 <p>Pull lever right to "UNFOLD" upper boom.</p>



# XT PRO SERIES

The following are mounted on the pedestal:

5.	Engine Stop/Start (Optional)		<p>Push and hold to start engine. Release when engine starts. Push and release to stop engine.</p> <p> <b>Can also be used to stop the Aerial Device in an emergency.</b></p>
6.	Two-Speed Throttle  *Auxiliary Let Down Power (Optional)	  	<p>With engine running, the throttle is activated. Push and release to increase engine RPM. Push and release to return to engine idle.</p> <p>With engine "OFF", the auxiliary let down power is activated. Push and hold to turn on auxiliary let down power. Release to shut off auxiliary let down power.</p>
<p><b>NOTE: *Can be included with two-speed throttle circuit. When vehicle engine is disabled, the auxiliary let down power can be activated by the two-speed throttle switch.</b></p> <p><b>NOTE: *Do not operate longer than 30 seconds. Continuous operation will drain battery and/or overheat pump motor.</b></p>			

## ACCESSORIES

### ENGINE STOP/START CONTROL (OPTIONAL)

The engine stop/start system allows the truck engine to be stopped and restarted from remote locations. Switches may be located in the cab, at the outrigger control location, at the pedestal or lower controls, or an air plunger at the platform.

Before attempting to start the engine, make sure the transmission is in neutral, the parking brake applied, and the wheels are chocked.

To start the engine make sure the vehicle key is in the run position and the master switch in the cab is "ON". Push the control labeled "ENGINE" and hold until the engine starts, then release.

The engine will crank as long as the control is held in the "START" mode. If it fails to start, release and let the starter cool down. The control toggles between start and stop mode, so it is necessary to push and release, then push again to crank the engine if the engine fails to start.

To stop the engine, push the control and then release. Refer to Emergency Operation for further information on the use of this control in an emergency.

**NOTE: Because of engine emission requirements some engines may not crank immediately when the key or the remote STOP/START buttons are pressed. There may be a delay of several seconds before cranking will begin. Hold the button until the engine cranks.**

### TWO-SPEED THROTTLE CONTROL (OPTIONAL)

The two-speed throttle control allows the engine speed to be increased to a high idle position or reduced to the normal idle speed from remote locations. This gives the operator a choice of an efficient, economical engine idle speed with slower boom movement or a faster engine speed with faster boom movements when required. Controls may be located at the outrigger control location, at the pedestal or lower controls, or in the platform. The control will alternate the engine speed between the high and standard idle speeds.

- To increase engine speed, push the switch or air plunger and release.
- To decrease engine speed to an idle, push the switch or air plunger and release.

**NOTE: If two speed is not installed, the unit may be equipped with an automatic full time high idle engine speed when PTO is activated.**

### AUXILIARY LET DOWN POWER CONTROL (OPTIONAL)

If the power source for the Aerial Device fails, the auxiliary let down power control activates power to stow the Aerial Device if the vehicle electrical system and the hydraulic system is operable. The auxiliary let down power control is combined with the two-speed throttle control. If the engine is not running, the auxiliary let down power is turned on and off by pressing and holding or releasing the two-speed throttle push button. If Aerial Device is not equipped with the two-speed throttle, the control only operates the auxiliary let down power.

**NOTE: The auxiliary let down power system should not be operated longer than 30 seconds continuously. Continuous use will drain the battery and damage (overheat) the auxiliary pump motor.**



### HYDRAULIC TOOLS (OPTIONAL)

Hydraulic tool circuits are used to attach hydraulic powered hand tools to the hydraulic system of the Aerial Device. Quick-disconnect couplings are used to attach hydraulic tools. There may be one or two sets of tool couplers. Only one set of tools can be used at a time.

The tool circuit is for open center hydraulic tools only. Use of closed center hydraulic tools will add excessive heat into the hydraulic system. Operate tools at low engine speed if equipped with two speed throttle. Do not operate tools while moving the boom.

### CONNECTING TOOLS

- Clean off couplers before making connections.
- Ensure the tool is off and in the center (neutral) position. First connect the tool's return hose to the return coupling and then connect the pressure hose to the pressure coupling.
- To remove tools, turn tool off in the center (neutral) position. Disconnect the pressure coupler first then the return coupler.
- Place dust covers on couplers to keep clean when not in use.



**Only use orange hoses marked “non-conductive” on tools. The use of tools with hoses that can conduct electricity may cause serious personal injury or death in the event that such hoses or tools come near or in contact with energized power lines.**

### USE OF TOOLS

- When tools are not required store them in the truck storage compartments. This will prevent damage to the tool and eliminate the chance of the tool falling.
- Remove tools from the platform when storing Aerial Device for transport.
- Turn tool off when not using tool.
- Do not operate hydraulic hand tools continuously. Continuous operation will cause overheating of the Aerial Device's hydraulic system.
- Turn tool circuit off when moving boom or platform.
- Use only orange, non-conductive hoses, on hydraulic tools.
- Be aware of where the tool hoses are to prevent snagging or contact with objects.
- Do not contact any conductor, pole, guy wire, or any objects with tool hoses, tool couplers or tool fittings. Contact can damage tool circuit and cause a leak.



**Contact of tool hose, quick coupler, or hose fittings against conductors can cause an arc that will burn through hose or fitting and result in a fire.**



**Hydraulic oil is flammable.**

The hydraulic tool circuit at the platform will allow the boom to move slowly if the tool is on. This is not to be used in normal operation. Two hands are to be used to control the hydraulic tools. If the tool circuit is left on with no tool connected, the oil will over heat. Always shut tools “OFF” when not in use or moving the booms.

**PLATFORM TILTING OPERATION (OPTIONAL)  
MECHANICAL TILTING (CONTROLS BETWEEN BOOM AND PLATFORM)**

Position booms so the upper boom is down at ground level. (This will allow platform to tilt without hitting boom.)

Stand on firm footing and hold platform securely.



**Do not attempt to dump the platform when inside platform.**

**NOTE: Do not drop platform after disengaging pins. Failure to hold platform could cause platform to tip too fast.**

Return platform to original position, insert both lock pins (1).

**WARNING**



**Fall Hazard**  
Falling can result in death or serious injury.

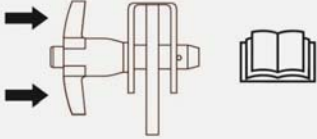

Both lock pins must be in place and pin lock preventing removal without depressing button.

612455

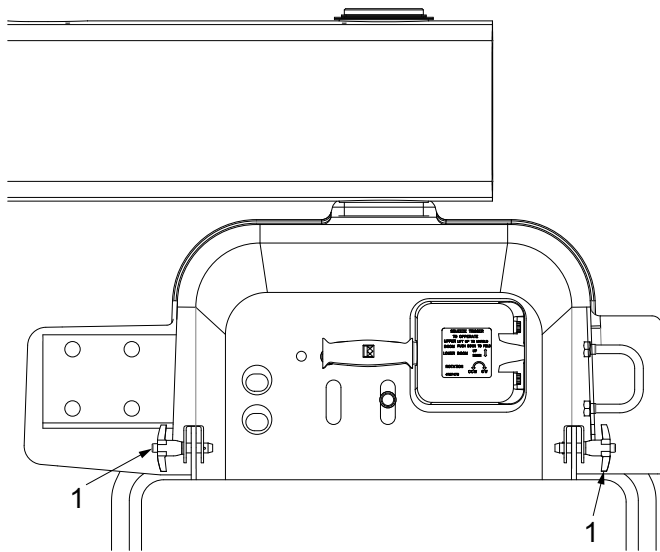

**MECHANICAL TILT**



**LOADING CAPACITIES**

**IMPORTANT:** This unit is designed for personnel lifting only. Do not tie or lift loads with the boom or platform. Platform capacity includes everything lifted in or on the platform including: operator, tools, material and platform liner. Refer to the ID plate for the gross platform capacity.

If the unit is equipped with a platform liner, the weight of the liner must be deducted from the platform capacity shown on the ID placard.

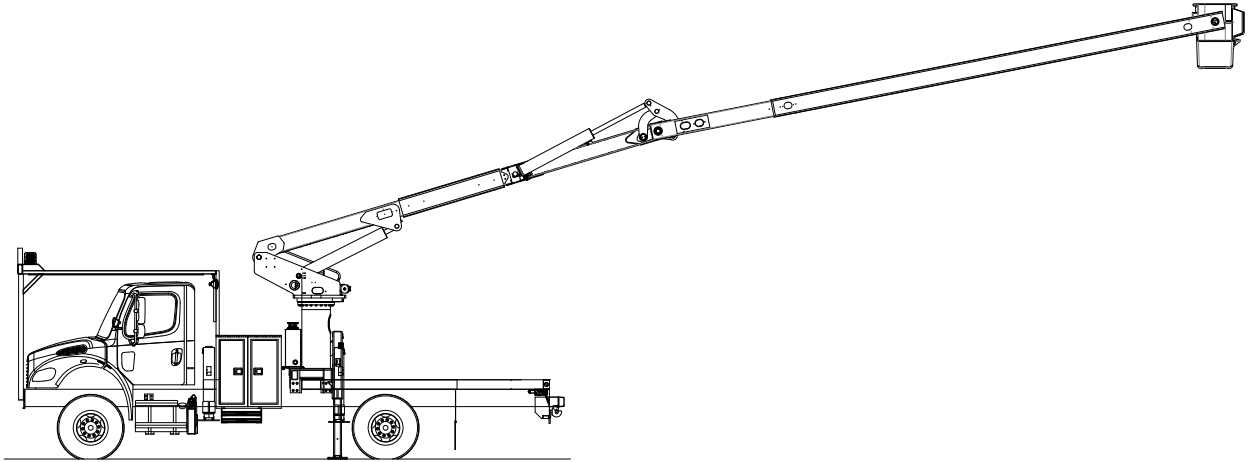

	<p><b>This Aerial Device has been tested for stability on a flat firm surface with a maximum slope of 5 degrees. Working on slopes that exceed 5 degrees may result in Aerial Device tipping over.</b></p>
--	--

Standard plastic platform liner weight for a single person 24 x 24 is 50 lbs.

**HYDRAULIC PLATFORM TILTING (OPTIONAL)**

The optional hydraulic tilt permits the platform to be tilted for cleaning out the platform or for rescue. The control is located in the lower controls.

1. Select lower controls.
2. Position booms so platform is at ground level.
3. Move lever as intended to dump platform.
4. Return to normal position before moving booms.
5. This control is to be used only for cleaning out the platform or rescue only. See Service Manual for procedure to adjust platform level.



**Do not operate with personnel in the platform except in case of emergency.**

**Do not use to adjust platform leveling. See Service Manual for level adjusting procedure.**

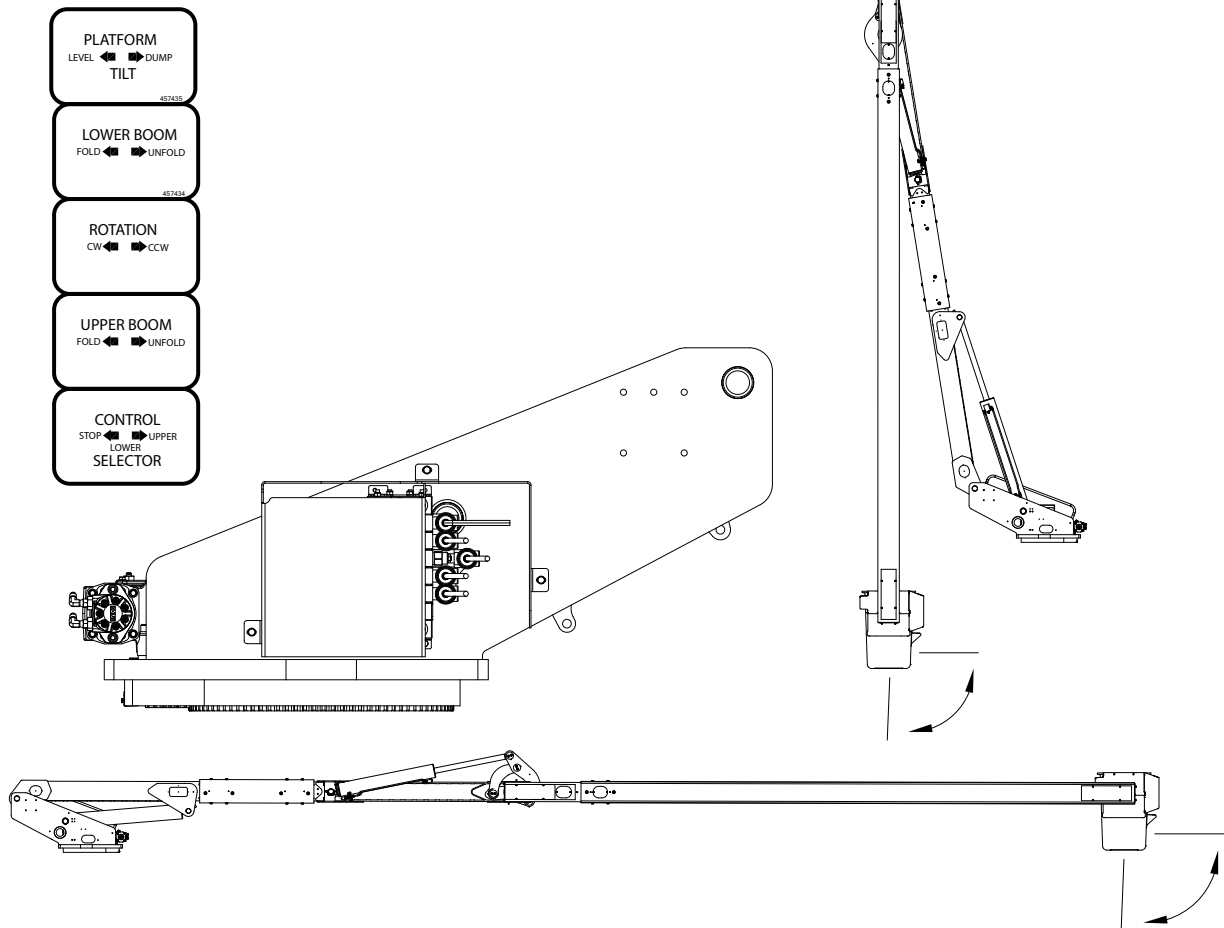

**HYDRAULIC TILT**



## PERSONNEL AND TRAINING

All personnel assigned to an Aerial Device shall be given an opportunity to become familiar with the operation of the equipment before they operate it on a job. The operator and all other personnel should be familiar with the operating procedures. The operator and personnel shall perform training operations until they attain a safe degree of proficiency.

**! DANGER**

**FAILURE TO OBEY THE FOLLOWING WILL RESULT IN DEATH OR SERIOUS INJURY**

- For stationary operation, truck must be securely parked, driveline disengaged, and Aerial Device properly stabilized prior to operation.
- To avoid tip-over, outriggers (when so equipped) must be properly extended on a solid level surface.
- Operate all controls slowly for a smooth platform motion and make sure controls are returned to neutral after desired operation.
- Crew must use proper personal and other protective equipment.
- Never load beyond rated capacity.
- Never operate Aerial Device with personnel under boom or load.
- Never move the truck until the booms and outriggers are in a properly stowed position and secured.
- Refer to the operator's manual for complete instructions. If missing, replace manual.

419262

**! DANGER**

**AN UNTRAINED OPERATOR SUBJECTS HIMSELF AND OTHERS TO DEATH OR SERIOUS INJURY**

**YOU MUST NOT OPERATE THIS MACHINE UNLESS**

- You have been trained in the safe operation of this machine.
- You have read, understand and follow the safety and operating recommendations contained in the machine manufacture's manuals, safety signs attached to equipment, your employer's work rules and applicable government regulations.
- You are sure the machine is operating properly and has been inspected and maintained in accordance with manufacturer's manuals.
- You are sure that all safety signs, guards and other safety features are in place and in proper condition.

419267

Know and understand the operators inspection and field maintenance requirements. Many times simple maintenance procedures can prevent expensive breakdowns. A brief preliminary check of oil levels, operating conditions of the Aerial Device, and visual inspection of pins, fasteners, and the hydraulic system should be made daily before each shift.

**! If a deficiency is found during the inspection, perform maintenance or repair immediately. Malfunction of one component can cause catastrophic failure resulting in serious injury or death if not corrected immediately.**

Continuous training and experience is required to achieve the proficiency and proper technique of operation necessary to efficiently and safely operate your Aerial Device.

**! The ground crew must be trained to operate the Aerial Device in case of emergency.**

**A WELL TRAINED CREW IS A PRODUCTIVE CREW!**



## PRE-OPERATION

### DAILY PRE-OPERATION CHECKS

Perform all daily inspections as shown in Frequent and Periodic Inspection immediately prior to first use at the beginning of each shift.

### JOB SITE SURVEY

Before positioning the vehicle to work, perform a complete survey of the job site. During the survey, look for items including the following:

- Ambient conditions including temperature.
- Consider the slope of the ground. Unit is tested on maximum 5 degree ground slope.
- Determine if the ground is firm enough to support the Aerial Device. If the vehicle must be parked on a slope, always keep the boom on the uphill side, chock the wheels, and work off the rear of the vehicle. If the ground is not firm enough, use pads under the outriggers and crib as needed to distribute the load.
- If unit is not equipped with outriggers, or only has one set of outriggers, evaluate the tire contact area. All tires and axle suspension springs must be equally loaded prior to setting outriggers.
- Look for ditches, drop-offs, holes, debris, and overhead utility and power lines.
- If grass or other combustible materials will be underneath when the vehicle is setup, follow company policies to prevent a fire.
- Determine the vehicle position needed to accomplish the work safely. If it is not safe to proceed use another method or setup.





## **OPERATING TEMPERATURE RANGE**

The ambient operating temperature range of the unit is given on the ID plate. Operation at the extremes of the temperature range requires extra precautions.

Cold weather operation below 10 degrees F (-12 degrees C) requires:

- The hydraulic system must be filled with hydraulic fluid having a pour point suitable for the temperature.
- The hydraulic system must be properly warmed up:
  - Operate the pump at idling speed to allow the oil to warm up gradually. Cold, thick, sluggish oil may not move fast enough and will starve the pump, thus causing severe damage.
  - Circulate the oil through the outrigger system by cycling each outrigger several times before setting up for boom operation.
  - Circulate the oil through the system by cycling each function from the lower controls before operation from the platform.
  - The addition of oil heaters may be required.
- Operate the boom and functions slowly to prevent jerking and shock loading.
- Functions may operate sluggish and not be as responsive, so allow more time and distance when starting and stopping movements.

Hot weather operation above 100 degrees F (38 degrees C) may require intermittent operation to allow the oil to cool or the addition of oil coolers. Do not exceed an oil temperature of 150 degrees F (66 degrees C).

## **WIND SPEED**

Do not operate the Aerial device or Digger Derrick at any wind speed that would create a potential hazard or does not allow safe operation for the work to be performed.

Allow for platform, boom and work-area movement, electrical line sway or sag during windy conditions.

Always account for windy conditions during the worksite inspection or survey.

NOTE: OSHA 1910.269 (x) (5) allows the use of Aerial devices and Digger Derricks up to a wind speed of 30 MPH (48 km/h). The OSHA general duty clause also requires the user to determine if conditions are safe before proceeding with work.

It is both the user's and operator's responsibility to conduct a thorough worksite inspection and determine if the work can be performed and the equipment operated safely in the conditions at the site. It is the responsibility of both the user and operator to also continuously monitor the worksite conditions and if conditions adversely change, to halt all operations until conditions allow for safe operation.

**JOB SITE SETUP**

Before locating the vehicle in position to work, perform a complete survey of the job site. Select a truck position that has a ground slope of less than 5 degrees. This Aerial Device has been tested for stability on a flat firm surface with a maximum slope of 5 degrees. Working on slopes that exceed 5 degrees may result in the Aerial Device tipping over. The chassis as built may have torsion bars only, one set of outriggers, or two sets of outriggers or a combination of torsion bars and outriggers. The unit has been tested for stability as equipped. The vehicle can only be used with the stability components as originally installed and tested. If the unit has outriggers they must all be used and set up properly for stability of the unit. If the unit has torsion bars they must be inspected and maintained to provide the force needed for stability.

- Determine if the vehicle is parked on a slope of 5 degrees or less by looking at the level indicator located by the outrigger controls or on the front of the truck body on units without outriggers and also evaluate the axle angle to the truck. The level indicators are only an operator aid, it will show if the angle at the indicator location is over 5 degrees but will not show if the ground is less than 5 degrees or how much the frame is twisted. The operator must visually verify the ground condition and that the truck axles uniformly support the truck weight. If the tires are hanging on one suspension spring, barely touching the ground, and the opposite suspension spring is up against the rubber stop, the frame angle is different than the axle angle. The axle suspension is not loaded uniformly and may not provide proper stability.
- The unit will be equipped with a level indicator, shown below. The ball must be in the green area. If the ball is in the red area, the truck is at an angle greater than 5 degrees and the truck position must be changed before use. Change the position of the truck by repositioning the truck or by cribbing the tires of the truck until it is less than 5 degrees and the suspension on each axle is uniformly loaded. If the truck is parked in a location with less than a 5 degrees slope and the tires equally support the truck and load, proceed to setup the unit.

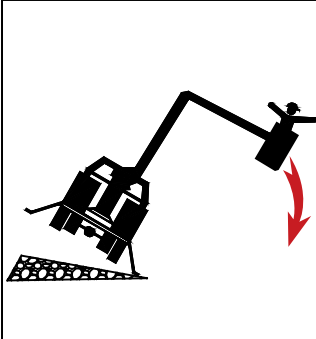

**! DANGER**

**OVERTURNING HAZARD  
DEATH OR SERIOUS INJURY**

May result from overturning machine

- This unit has been tested for stability on a maximum slope of 5 degrees.
- Working on slopes that exceed 5 degrees may result in truck tipping over.
- All tires must remain on the ground.
- Position or park truck so indicator is in the green area.
- Set Outriggers (if equipped) so indicator remains in green area.

458696A



**LEVEL INDICATOR**



**Working on slopes that exceed 5 degrees may result in vehicle tipping over. The level indicators are only an operator aid, it will show if the angle is over 5 degrees at the indicator location but will not show if the ground is less than 5 degrees or frame twisted. The operator must visually verify the ground condition.**

- If unit is not equipped with outriggers, or only has one set of outriggers the tires and suspension on each side of each axle must uniformly support the truck and load because they are part of the stability system when operating the Aerial Device. If one tire and axle spring is not loaded the same as the opposite, on that axle, it will not be able to provide the stability needed.
  - A tire cannot be in a hole or depression even if the truck is parked and the indicators show less than 5 degree angle.

If unit is equipped with two sets of outriggers, the axles not between the outriggers must equally support the load of the truck so the suspension on each side is equally loaded.

	<b>On Aerial Devices with no outriggers or only one set of outriggers the tires and truck suspension are a very important part of the stability system.</b>
	<ul style="list-style-type: none"><li>• Tires must not be parked in holes or depressions.</li><li>• Truck suspension must be equally loaded on each axle to provide support prior to setting outriggers.</li><li>• Tire pressures must be correct.</li></ul>

**Use the following procedure after the vehicle is in position at the work site:**

- Turn on warning lights as you approach the work site or after the Aerial Device is in position according to your employer’s policies.
- Place vehicle in neutral and set brakes before leaving cab.
- Chock the wheels.
- Position and use signs, warning lights, and barricades in accordance with OSHA, ANSI, state, and company rules and regulations.
- When work is to be performed on or near power lines, ground and/or barricade vehicle according to your company policy. If using a temporary ground connect grounding cable clamped to a static line or neutral, or use drive or screw type ground rod to ground truck according to your company policy. Unroll ground cable fully and spread out so cable does not cross over.
- Engage the power take-off (PTO) following the directions given with the specific PTO installed on the truck.
- Turn master switch on to energize unit electrical systems. (May also function as PTO Switch.)
- Set the outriggers (if equipped).

	<b>If the unit is equipped with outriggers, all outriggers must be set properly to provide adequate stability.</b>
---	--

## SETTING THE OUTRIGGERS

Before lifting or rotating the Aerial Device, all outriggers (if equipped) must be lowered firmly to the ground on a surface that can support the load, and kept there until all work is complete and the Aerial Device is stowed for travel. The stability of the Aerial Device depends on the gross weight of the vehicle, platform, the slope of the ground in the work area, and whether the ground is firm enough to support the load imposed. The condition of the truck tires, axles, torsion bars, outriggers and outrigger pads or cribbing all contribute to proper stability. These conditions are widely variable, so the operator must exercise good judgment and caution when setting the outriggers before utilization of the Aerial Device.

The method of setting the outriggers will vary depending on the number of outriggers and configuration. If the vehicle is equipped with one set of outriggers, the tires and the spring force of the truck axle work with the outriggers to provide stability. The location of the outriggers relative to the truck axles and the pedestal will determine how much the outriggers can be extended.

When lowering the outriggers:

- Determine if truck is properly parked with brakes applied and wheels chocked.
- Position the outrigger pads and verify that the surface will support the outrigger force, crib as required.
- Before lowering the outriggers, check the area where the outriggers will extend to verify no personnel or other objects are in the path. Operator must watch the outrigger while in motion.

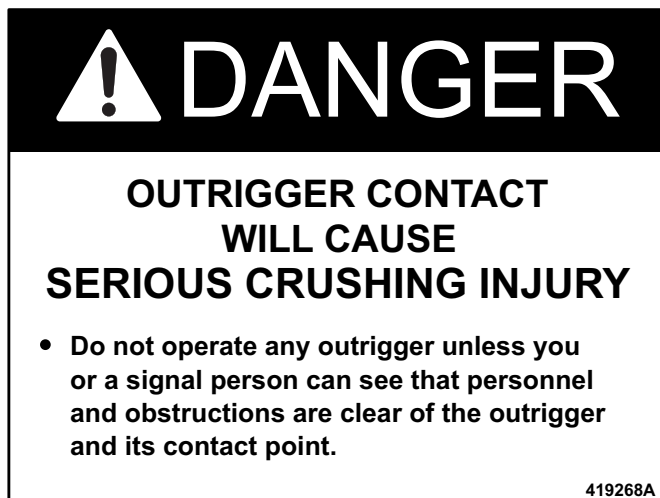

- Units with one set of outriggers behind the rear axles on rear axle mounts, extend the outriggers until the weight of the vehicle is off the springs. Rear tires must remain on the ground.
- Units with one set of outriggers between the axles on behind-the-cab mounts, set the outriggers firmly on the ground, but do not raise the weight of the vehicle off the springs. Tires must remain on the ground with the truck suspension providing equal support on each side of each axle.
  - Do not attempt to correct the ground slope with the outriggers; this unloads the low side tires and suspension. The suspension may not provide enough force for stability.
  - After setting the outriggers evaluate the truck position and setup. Determine if the tires are equally supporting the load by looking at the clearance to the fenders, body, or bed and the axle location to the axle stop, (rubber bumper) and overload springs. If one tire is closer to the body and the other tires on the opposite side of the same axle is further away from the body the unit is not set up properly. The spring deflection on each side must be the same or the overload springs or rubber bumper both in contact with their stops. Tires on the low side must be cribbed to equalize the truck suspension, providing the tire force needed for stability.



- Two sets of outriggers: The outriggers are extended to support the weight of the unit. The tires must remain in contact with the ground.
  - The vehicle can be leveled slightly with the outriggers.
  - The axles not located between the outriggers must equally support the load of the truck so the suspension on each side is equally loaded.



**The outrigger moving alarm will sound when the outrigger control is activated. If the alarm does not sound, it must be repaired.**

**SETTING UP ON A SLOPE**

If the chassis is set-up across the slope as shown below, the surface can be up to 5 degrees from level but must be firm and flat where tires are located. If one side of the chassis is low, extend the high side outrigger first and make sure that firm contact is made. If full extension does not make firm contact, the outrigger pad must be blocked up. Always chock the wheels. If the slope exceeds 5 degrees before setting the outriggers the tires must also be blocked and cribbed so the truck is parked at less than 5 degrees. If the unit has one set of outriggers do not level the truck with the outriggers. On units with one set of outriggers using the outriggers to level the truck does not change the slope, it reduces the truck suspension's ability to support the load and provide stability.

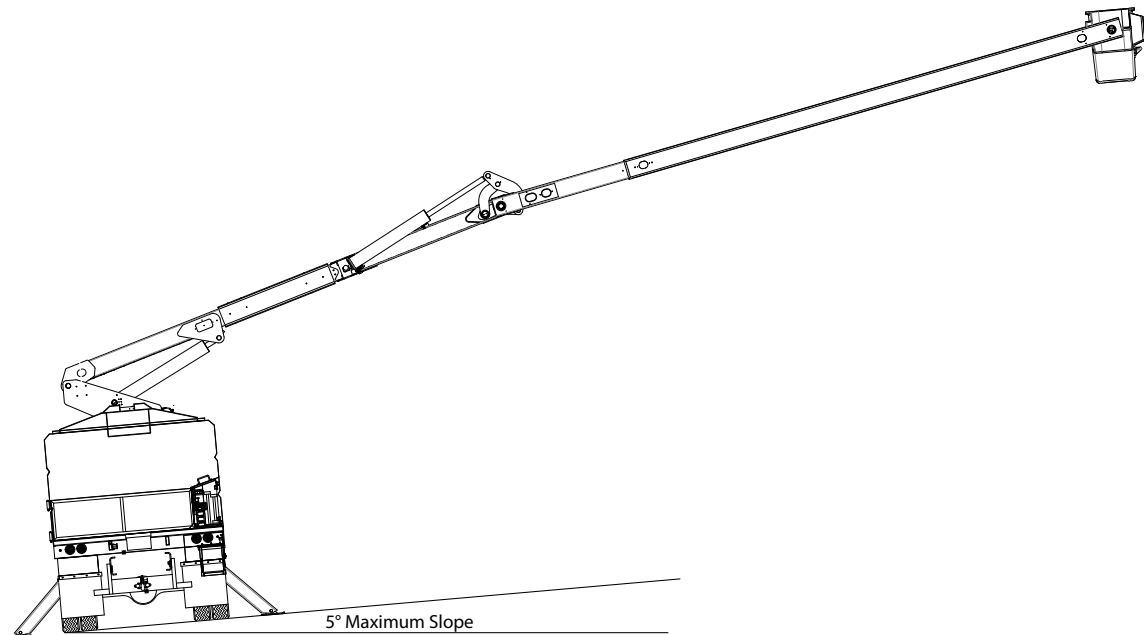

**CHASSIS SETUP ACROSS THE SLOPE**



**Working on slopes that exceed 5 degrees may result in Aerial Device tipping over.**

If the chassis must be set up with the slope, always keep the boom on the uphill side of the chassis, always chock the wheels, and always work off the rear of the chassis.

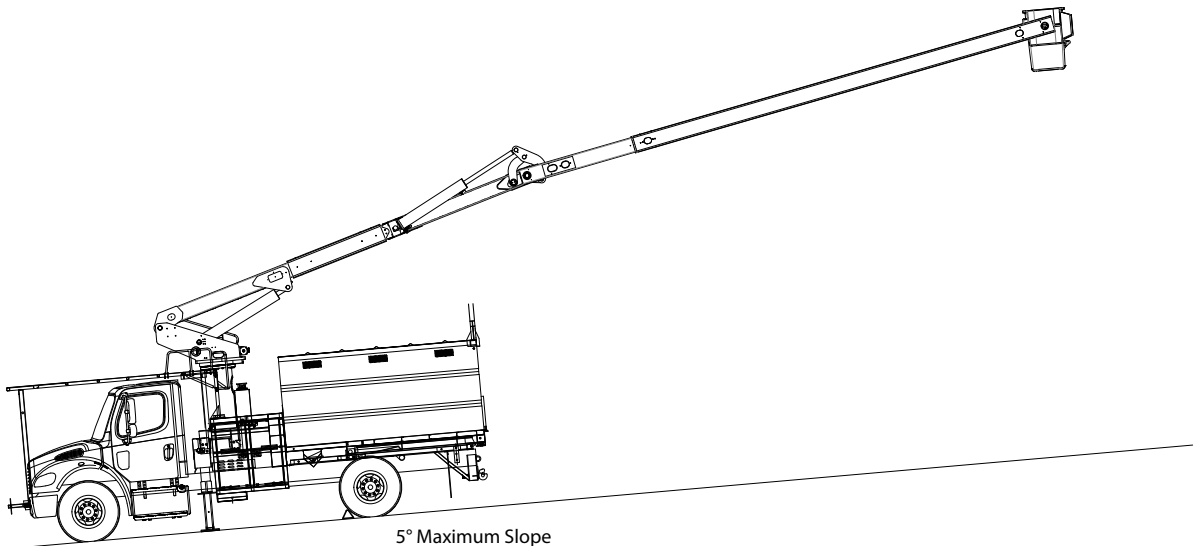

**CHASSIS SETUP WITH THE SLOPE**



**Working on slopes that exceed 5 degrees may result in Aerial Device tipping over.**

If the outrigger support surface is not level with the truck, the bank may need to be cut away or brought up to a level so the outrigger will provide proper support. The ground must be able to support the load of the outrigger without sinking. If the chassis must be set up where an outrigger extends into a ditch or gutter and the full extension does not make firm contact, the outrigger must be blocked or cribbed up. If the vehicle must be set up so an outrigger would be set on a curb with the vehicle in the street, the outrigger span will be shortened and the stability will be affected over that outrigger. Reposition the vehicle. All of the above conditions may affect the stability of the vehicle.

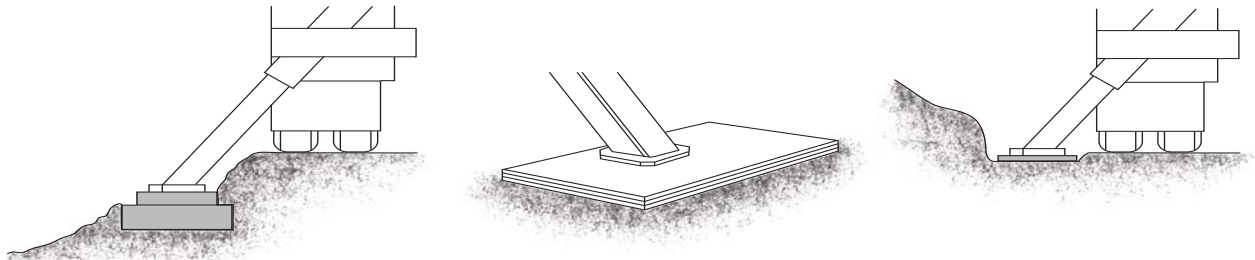

Chock the wheels to prevent motion of the truck. Cribbing (if required) must provide stable support for the Aerial Device.

If the chassis must be set up so an outrigger rests on a curb with the Aerial Device in the street, the outrigger span will be shortened and stability is reduced. The curb must have sufficient strength to support the load.

The conditions above may effect the stability of the Aerial Device, proceed with caution to prevent over-turning.

**SETTING UP ON A SOFT SURFACE**

If the ground is too soft to support the outrigger load or wheel load, mats or pads must be used. If the ground will not support the load the unit cannot be used at that location. Make certain the tires and outriggers are centered on the pads and the cribbing provides stable support as the booms are moved.



## SETTING UP FOR OPERATION ON SNOW AND ICE

Operation on snow and ice adds an additional problem due to the slippery conditions. Normal traction is greatly reduced. Just as you need to maintain traction to walk and drive, it is required to keep Digger Derricks and Aerial Devices in a stable position. Rotating and moving the booms may cause the truck to jerk and move. If the unit is not set up securely the truck can slide on ice and snow while operating. When planning your work remember that driving in snow causes snow dust to be deposited on all surfaces. The outriggers and outrigger pads will get snow covered and slippery. Also, as you put pressure on snow, the snow packs down and turns to ice. The person setting the unit up for operation has the entire responsibility for a stable position. The person on the site is the only one who can evaluate the conditions and terrain.

### Proper set up requires:

- Evaluate the terrain to determine the most flat and level set up position.
- Set up truck so if the truck does move slightly, the result isn't catastrophic.
- Set the parking brakes
- Chock wheels as required, to prevent movement down hill. Evaluate chock location to prevent the truck pivoting around one chock.
- Outrigger feet to not slide on the outrigger pads during use.
- Outrigger pads do not slide on the ground during use.
- Set units with one set of outriggers so all tires remain on the ground.
- Follow Operators manual for set up instructions. Do not place outriggers on Ice as slippage may occur regardless of solid footing.

### To properly set up you may need to:

- Remove snow and ice down to bare ground to prevent sliding and to evaluate the support available. Don't set outriggers on a manhole cover or the edge of a slope or drop off.
- Move as far as required into the street or road so if the truck does move, the tires and outriggers will not slide into the ditch or other hazards.
- Choose a location for the truck that gives the best stability for the work to be done.
- Come back later, to do the work, if the roads are not cleared sufficiently.
- Use traction aids under the tires and outriggers such as sand and gravel or mats.
- Operate the unit smoothly by "feathering" the controls, not jerking the levers.

## OUTRIGGER/UNIT CONTROL SELECTOR

The Outrigger/Unit Control Selector must be in the "OUTRIGGER" position to raise or lower the outriggers. The lever must be in the "UNIT" position to operate the boom functions. If equipped with hydraulic tools at the outrigger valve, the tools will have priority over other operations. When the tools are "on", the "UNIT" and "OUTRIGGERS" will not get hydraulic oil flow and will not operate.



**Do not use, connect, or disconnect the lower hydraulic tool if the booms are in or near energized lines. Death or serious injury may result if the truck becomes energized.**



## OUTRIGGER INTERLOCK

If the completed unit requires outriggers for stability it will be equipped with Outrigger Interlock. Outrigger Interlock will prevent boom operation unless the outriggers are extended. The booms will not operate if the outriggers are not extended past a predetermined point. The operator is responsible to set the outriggers properly to provide stability. If the booms do not operate and the Outrigger/Unit Control Selector is selected to "UNIT" then verify the outriggers are properly extended. The boom interlock does not assure Aerial Device stability, it is only an operator aid. It only serves to remind the operator that the outriggers have not been deployed.

To verify operation of the interlock:

- With o/r's retracted, select unit and try to operate the boom. It must not operate.
- Lower all outriggers and verify boom operation.
- Retract one outrigger and try to operate the boom. It must not operate.
- After verifying operation, extend the outrigger before moving on to the next outrigger.
- Repeat for each outrigger. If the boom operates with any outrigger retracted, repair before use.

## TORSION BARS (OPTIONAL)

Torsion bars may be installed on the rear axle, front axle, or both; alone or in addition to outriggers. If the vehicle has torsion bars, the tires and suspension are important because they are providing the stability. Check the tire pressure and condition before each use of the Aerial Device. The tires must be on solid footing, with each tire equally loaded. If not, use pads and cribbing as required, or reposition the vehicle to solid ground. Refer to the level indicators to be sure the vehicle is parked at less than 5 degrees from level. If not, wheels must be cribbed to level the vehicle to less than 5 degrees slope. Verify the tires are not in a depression. All tires must be equally loaded to provide support. To determine if the tires are equally loaded, check the spring deflection on each side. The deflection must be the same or the overload springs or rubber bumper both in contact with their stops. Also the tire clearance to the body on each side needs to be similar.

## STABILITY

The stability of a vehicle equipped with a rotating aerial device depends on the gross weight of the vehicle and platform capacity, the slope of the work area, and whether the ground is firm enough to support the force on the outrigger pads. These conditions are widely variable, so the operator must exercise good judgement.

**IMPORTANT: Know the platform capacities of your unit which includes operator(s), liner, tools, and debris.**



**This Aerial Device has been tested for stability on a flat firm surface with a maximum slope of 5 degrees. Working on slopes that exceed 5 degrees may result in vehicle tipping over.**



**Verify that you have the proper tire pressure stated by the vehicle manufacturer.**



## OPERATION

### UNSTORE THE BOOM

Before attempting to raise the booms, remove all boom hold down straps. Verify that the area overhead is clear before lifting the upper boom than the lower boom off the rest and elevate it high enough to clear all body obstructions before rotating.

### BOOM OPERATION

All boom movements should be smooth. Avoid jerking by slowly metering the control valves when starting and stopping all motions. Start and stop all boom movements by “feathering” the controls for smooth operation, allowing enough distance to slow the boom and safely stop when approaching obstacles. Be aware of the elbow and boom positions to prevent contact during all boom operations.

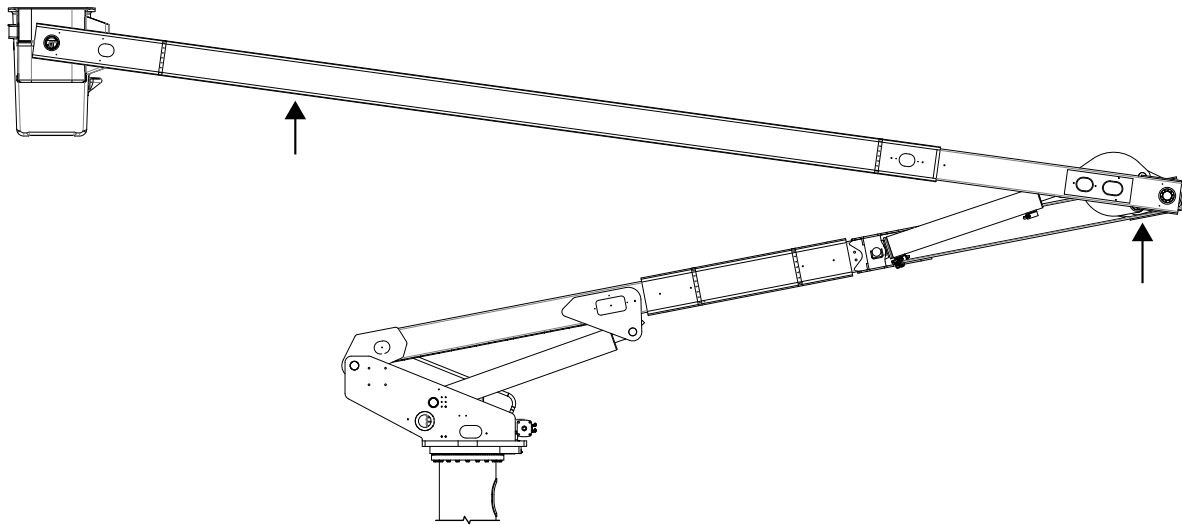

**CLEAR ALL OBSTRUCTIONS BEFORE ROTATING**



**Make certain that all personnel are safely out of the work zone and that there is sufficient overhead clearance before operating the Aerial Device.**

**AERIAL OPERATION**

Before using the Aerial Device, the operator must perform the pre-operational checks and inspections at the start of each shift. Verify the vehicle is properly positioned with outriggers (if equipped) firmly in place.



**Your safety is involved when elevated. Inspect and maintain the unit according to manufacturer's and your employer's policies.**

Before entering the platform, place the outrigger control selector (if equipped) to UNIT, and the lower control selector to the upper controls.

**ENTERING THE PLATFORM**

Use steps and handhold's for safe access to the platform. Each person will have different methods of entering based on there physical attributes. Once at the platform use the top lip as a handhold when getting into platform. There are several step options both inside and outside the platform, if needed such as liners with steps, hanging steps, or scuff pads for the platform with steps. Do not locate or hang tools, tool bag, or equipment that will interfere with safe access.



**When entering or exiting the platform be aware of where your lanyard is to prevent tangling with your feet or legs causing tripping.**

After entering the platform, connect your lanyard to the anchor located on the platform bracket. An OSHA Approved Fall Arrest System must be used.

The indicated number of lanyards may be attached to the lanyard anchor provided, one as indicated by X1 on decals.

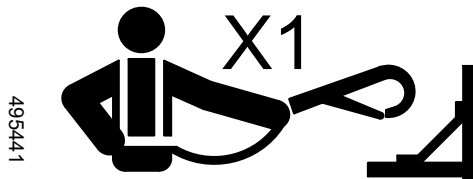



**DANGER**

**READ CAREFULLY**

- OCCUPANTS OF THE BASKETS OF THIS AERIAL DEVICE HAVE ABSOLUTELY NO ELECTRICAL PROTECTION FROM CONTACT BY THE HUMAN BODY WITH TWO ENERGIZED CONDUCTORS OR BETWEEN AN ENERGIZED CONDUCTOR AND A GROUNDED CONDUCTOR.
- It makes no difference if this contact is accidental or deliberate or whether contact is made through metallic parts of the basket, basket support, metal tools or equipment brought into the basket. The insulating components of this aerial device do not offer protection in the event of such contact.
- Proper conductor cover up, insulated sleeves and gloves shall be worn when working near energized lines or equipment.

**DEATH OR SERIOUS INJURY WILL RESULT FROM SUCH CONTACT OR INADEQUATE CLEARANCE**

414590A



**! DANGER**

**FALLING FROM PLATFORM WILL RESULT IN DEATH OR SERIOUS INJURY**

- Platform personnel must wear an OSHA approved fall protection system with lanyard attached to anchor provided.
- Platform doors, if provided, must be securely latched.



419264A

**! DANGER**

**ELECTROCUTION HAZARD THIS MACHINE IS NOT INSULATED**

**DEATH OR SERIOUS INJURY**

Will result from contact with or inadequate clearance to electrical power lines and apparatus

- Maintain safe clearance from electrical power lines in accordance with applicable government regulations. Allow for boom, platform, electrical line and load line sway.
- This machine does not provide protection from contact with or proximity to an electrically charged power line.
- Boom and platform must be kept below all electric power lines.
- Do not use for work on electric power lines.

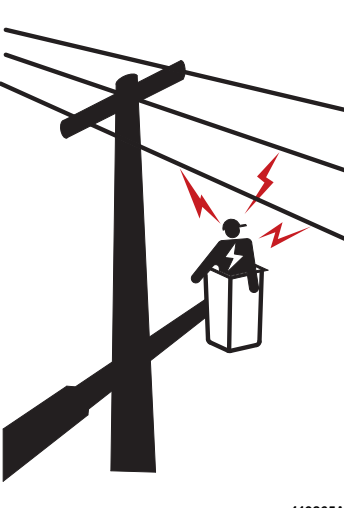

419265A



ARROWS  
BOOM TIP  
(ALL PARTS PAST ARROWS)

**! DANGER**

**ELECTROCUTION HAZARD**

**CONTROLS ARE NOT INSULATED OR ISOLATED**

All metal at boom tip is electrically connected. Operator contact with ANY, live or grounded, line or object while operator touches CONTROLS or BOOM TIP COMPONENTS and boom tip contacts any other line or object can result in

**DEATH OR SERIOUS INJURY**

Comply with OSHA, ANSI, & NESC requirements

- Maintain proper CLEARANCE to all lines and objects
- Wear Personal Protective Equipment: Fall protection; Eye protection; Insulating: gloves, sleeves, and hard hat; & Special clothing
- Cover all lines with insulated line hose or insulating blankets
- DO NOT Depend on machine covers for insulation. Plastic or fiberglass covers offer limited electrical insulation. Covers are NOT tested, certified, or maintained as insulating.

463602A

**! Do not allow any part of the Aerial Device to come in contact with any electrical conductors, either energized or non-energized.**



Use protective equipment suitable for the work being performed.

Follow your employer's policies for personal protective equipment. Failure to wear proper PPE can result in death or serious injury.

- Wear insulating gloves and sleeves when working on or near electrical equipment.
- Install hose, covers, and mats on all energized and grounded conductors.
- Wear protective and insulating headgear.
- Use a platform liner.



**Do not move the vehicle with personnel in the platform. This Aerial Device is not designed for mobile operation or travel with the platform occupied. Only the seating areas specified by the vehicle manufacturer with seat belts are suitable for use during travel.**

Determine the movements required to reach the work location. Feather the controls to smoothly start and stop the Aerial Device movements. Use slow deliberate movements, when approaching the aerial job site. Use high speeds only when traveling to and from the job site in open areas with no obstacles. Use slower, controlled speeds when moving in the job site or around obstacles. Look in the direction the Aerial Device is traveling to be certain there is clearance for the boom(s), platform, and operator.

Be aware of any obstacles the booms; including elbow, and platform, may strike if rotated or elevated, and any objects that the booms may come close to as movements are made.



**Do not leave the platform to build trestles between the platform and another work location.**



**Avoid careless handling of tools and equipment while elevated. Use a non-conductive tool tray to help prevent dropping items. Keep all ground personnel away from the area directly under the work zone unless absolutely necessary, and caution them that it is necessary to be constantly on the alert for possible falling items.**



**Use orange hose marked NON-CONDUCTIVE for tool hoses, at the boom tip, and areas that bridge the insulation gap.**



**Do not let hoses hang where they can catch on or contact energized conductors or grounded conductors on any structure.**



**The Aerial Device upper control station has metallic parts, which are necessary to provide the structural support for the various components. These metallic parts are interconnected. The main shaft that supports the platform and controls must also support other load carrying options that can be added to the boom tip.**

**The fiberglass upper and lower boom, in a well maintained condition, provides electrical insulation between the boom tip and the truck as a potential to earth ground. This fiberglass will not protect the operator in the platform if any portion of the boom tip, including options, is brought into contact with an energized or non-energized conductor and the operator is in contact with a different potential, such as, a grounded non-energized conductor. This type of contact can energize or ground the controls because as stated before, all components of the boom tip are interconnected. The fiberglass will not provide protection for the operator in phase to phase contact or a phase to earth ground contact, nor will it protect the vehicle from becoming energized if the steel boom section below the lower boom insert, if so equipped, is brought into contact with an energized conductor.**

 **Do not depend on Aerial Device covers for insulation. Covers are not tested, certified or maintained as insulating.**

### DUMPING CHIP BOX

Set outriggers per the outrigger setup in this manual. Using the lower controls elevate the upper boom to clear obstructions and lower boom to approximately 45 degrees.

To elevate the chip box open the rear gate securing the gate to the side of the body. The selector shall be in the outrigger position. Elevate the chip box by using the dump up control.

 **All personnel shall not be under chip box without safety strut in position to prevent chip box from falling and causing crushing injury.**

Once the chip box is emptied lower the chip box fully into the stored position before storing the booms per the boom storage procedure in this manual.



## EMERGENCY OPERATION

Emergency operation may be required if an operator is injured or the equipment malfunctions. In any emergency, the first priority is always the safety of the personnel involved. It is always important to remember to follow the standard work practices and the safety regulations that apply. If the Aerial Device is operable, move the platform away from the danger and into the shortest, clear path of descent to get the operator on the ground. If the Aerial Device is inoperable, consider using another Aerial Device to rescue the operator from the platform. If the equipment is damaged or malfunctioning, do not allow anyone to enter the platform. Instead if the situation allows safe operation from the lower controls, override the upper controls and carefully lower the platform to the ground. Operate only one lower control at a time when overriding the upper control.

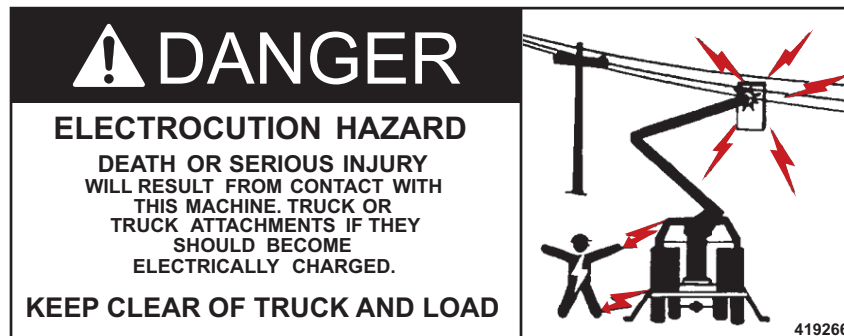

**Do not touch the truck or attachments and the ground at the same time. If the truck, including Aerial Device or any attachment connected to the truck, contacts a power line, you will be a path for the current. Death or serious injury will result.**

## POWER LINE CONTACT ON GROUND

### VEHICLE IS TOUCHING A POWER LINE

Follow your companies policies for emergency situations. Company policies take precedence over this manual. Take these steps if your vehicle makes contact with a live power line while you are in or on the vehicle:

- Treat any line, as live unless you know for sure it is not.
- Stay inside or on the vehicle until the power is disconnected or turned off.
- Warn others to stay away from the vehicle and any trailers or attachments.
- If you must get away from the vehicle because of fire or other danger:
  - Jump out and away from vehicle.
  - Do not touch the vehicle and ground at the same time.
  - Land with your feet close together.
  - Shuffle away taking very small steps keeping feet together.
- Do not try to help others out of the vehicle. Contact with the machine or someone on the machine will create a path through you to ground causing serious injury or death.

### STANDING ON GROUND CLOSE TO FALLEN POWER LINE

You must shuffle keeping feet together, do not run. The voltage is highest where contact is made and decreases as you get farther away from the point of contact. The distance will depend on the ground conditions and conductivity of the ground. If you run, your legs will bridge from higher to lower voltage and current will pass through your feet and legs. Keep your feet together and shuffle to go from one voltage gradient to the next gradually. This will decrease the chance of electrocution as you move away from the vehicle or fallen wire.

- Never touch a fallen power line unless you are trained and properly equipped to handle it safely.
- Shuffle away using very small steps keeping feet together; do not run.
- Do not touch anything as you leave the area.
- Warn other people to stay away from the area.
- Immediately notify the proper authorities or people to correct the problem.



**In an electrical emergency: Stay calm and think before you act. Don't become a victim while helping someone else.**

### APPROACHING A VEHICLE THAT MAY BE ENERGIZED

In an emergency situation, it may be necessary for ground personnel to operate the Aerial Device. The entire vehicle and any attachments must be considered energized any time the booms are in the vicinity of power lines.



**Ground personnel must know the proper operation and emergency procedures for the Aerial Device. If there is an accident or the operator is incapacitated, the ground personnel will be required to assist in rescue operations following your company policies.**

If you must approach a vehicle to perform a rescue operation, understand and follow your company policy. It will take precedence over these instructions. You must be very careful not to touch the vehicle and the ground at the same time or your body will be in a circuit and current may pass from foot to foot or foot to hand. The condition of the ground and subsurface will determine the electric gradient around the vehicle.

Follow your employer's policies for emergency situations.

**BEFORE TRYING TO GET ON OR APPROACHING A VEHICLE THAT MAY BE ENERGIZED:**

- Is it necessary to approach the vehicle? Can the operator handle the problem from the platform?
- The best procedure is to disconnect or shut off the power to the lines.
- Do not let anyone approach the vehicle until you evaluate where the power line contacts the Aerial Device.
  - Is it above the insulated section of the upper boom?
  - Is it above the lower boom insulated section?
  - Is it below any insulated sections and a direct short to the vehicle?
- If the vehicle is grounded properly:
  - Use a hot stick or hot line tool to perform the operation.
  - Approach the vehicle using shuffling steps, keeping feet close together.
  - Lay a rubber blanket down by the vehicle and step on it before attempting to jump on the vehicle.
  - Do not touch the ground and the vehicle at the same time. Even a properly grounded vehicle may have a lethal voltage difference between the truck and ground.
- If the vehicle is not grounded:
  - Do not approach the vehicle unless you use insulated blankets to step on as you approach the vehicle. Stepping from one rubber blanket to the next.
  - Use a hot stick or hot line tool to perform the rescue operation while standing on the rubber blanket.
  - As a last resort, jump onto the vehicle.
  - Do not touch the ground and the vehicle at the same time.





### CONTROL SELECTOR

To operate the lower controls or the platform controls, the control selector must be in the position for the desired controls to be operated. When a situation requires use of lower controls to override the upper controls (such as, injured personnel in the platform), use the control selector at the lower controls to select the “lower” controls for operation of the Aerial Device. This will make the upper controls inoperable. Then “lower” controls can be used to lower the operator to the ground, provided the upper controls are intact. The Control Selector functions as an emergency stop by taking oil flow away from the active controls. Operate only one lower control at a time when overriding the upper control.

If the operator is unable to operate the Aerial Device, determine if any damage has occurred to make the Aerial Device inoperable. If the situation allows safe operation from the lower controls, override the upper controls and carefully lower the platform to the ground. If the Aerial Device will not operate due to the damage incurred, consider one of the other auxiliary operating procedures presented in this section to solve the problem.



### MANUAL ROTATION

If all the hydraulic power sources become inoperable, the Aerial Device rotation system can be actuated manually. Use a 7/8 in. hex socket, an extension, and a ratchet to rotate the input shaft on the gearbox. Actuating the lower rotation control will reduce the effort required for the rotation.

### AUXILIARY LET DOWN POWER (OPTIONAL)

The auxiliary let down power system provides power from a DC motor-pump for operation of the Aerial Device in case of a prime power source failure. Controls for auxiliary let down power may be located at the platform, pedestal (optional), and outrigger (optional).

At the platform, the auxiliary let down power is operated by an air cylinder located with the upper controls. To activate this system, push and hold the air cylinder’s plunger knob (labeled “Auxiliary Power”) then operate the controls. The pump will engage after a 10 second delay. To turn “off” the power, release the air cylinder’s plunger knob. The auxiliary let down power system should not be continuously operated longer than 30 seconds. Continuous use will drain the battery and damage (overheat) the motor.

At the pedestal and the outrigger controls (if equipped), the auxiliary let down power is operated by a push button switch. To activate this system, push and hold the switch, the pump will engage after a 10 seconds delay. To turn “off” the power, release the switch. The auxiliary let down power system should not be continuously operated any longer than 30 seconds. Continuous use will drain the battery and damage (overheat) the motor.

Do not use the let down pump as an auxiliary pump. Use the let down pump only to lower the booms and/or raise the outriggers when either the main pump or engine malfunctions. Using the pump to raise the booms may cause damage to the let down pump motor.

Test the auxiliary let-down system daily to ensure the system will operate properly when needed.



## HYDRAULIC LINE FAILURE

Hydraulic line failure during Aerial Device operation presents numerous hazards. Be aware that a hydraulic oil mist caused by a leak or hydraulic line failure is conductive even though nonconducting oil is used.



**A spray or mist produced by a hydraulic leak under pressure is very hazardous to personnel. This spray or mist can puncture the skin or become embedded beneath the skin. This condition would require immediate medical attention.**

**WARNING**

**Escaping fluid under pressure can penetrate skin causing serious injury.**

**Relieve pressure before disconnecting hydraulic lines. Keep away from leaks and pin holes. Use a piece of cardboard or paper to search for leaks. Do not use your hand.**

**Fluid injected into skin must be surgically removed within a few hours by a doctor familiar with this type injury or gangrene will result.**

H23877A

### WHAT CAN CAUSE A HYDRAULIC LINE TO FAIL?

- Poorly maintained hydraulic system.
- Improperly assembled and installed hydraulic lines.
- Weather damaged hose assemblies.
- Hydraulic tool hoses that contact energized conductors phase to phase or phase to ground.
- Boom contact with phases causing a short circuit, which overheats the hydraulic line.
- Improper system pressure setting.
- Overheating the hydraulic system.
- Snagging of hydraulic lines on fixed objects.



### WHAT CAN HAPPEN WHEN HYDRAULIC LINES FAIL?

Hydraulic oil, when confined within the hydraulic system and properly maintained, is non-conductive and not subject to being ignited. There are numerous hazards that develop when there is a hydraulic line separation:

- Personnel may suffer burns from contact with hot oil.
- A vacuum may be created in the line and breach the insulated portion of the booms causing the Aerial Device to be conductive.
- If the hydraulic line failure creates a mist of oil, it very easily can be ignited by any outside source of ignition; such as, electric arcing, sparks, and flames.
- The reservoir may be drained of oil, which will make the Aerial Device inoperable.

### WHAT TO DO IF HYDRAULIC LINES FAIL?

A quick response to stop oil flow caused by a hydraulic line failure is important to prevent further damage and prevent injury.

The following sequence can be used to stop the flow.

From The Platform

- Release the function being operated. Shut off tool valve if tool, tool hoses, or tool connections are involved.
- Activate the emergency stop control, which will divert the flow back to the tank.
- Activate the engine stop/start switch, if so equipped. This will stop the engine driving the pump.
- Get ground assistance if all of these fail to stop the flow of oil.



**The vehicle may be energized. If mounting or operating the vehicle from the ground, use proper personal protective equipment; such as insulating rubber gloves, rubber boots, rubber mats, and/or a hot stick. See Emergency Operation section for procedure to approach vehicle.**

From The Vehicle Bed

- Move the control selector at the lower controls to the lower control position. This will stop all flow to upper controls.
- Push the engine stop/start switch, if so equipped. This will stop the engine driving the pump.

From The Ground

- Shut off the pump engine. This will stop the pump.
- Disengage the power take-off. This will stop the pump.
- Move the control selector at the outrigger control valve to the outrigger position. This will stop all flow to the Aerial Device and send it to the outrigger circuit.
- Push the engine stop/start, if so equipped. This will stop the engine driving the pump.

Once the flow is stopped, determine where the line failure is located. The following examples describe some emergency procedures that can be followed for some specific types of hydraulic line failures:

- If the line failure is between the upper and lower controls, overriding the upper controls and only operating from the lower controls may reduce the rate of hydraulic oil loss. The intermittent loss of hydraulic oil may allow the Aerial Device to be stored.
- It may be necessary to use another Aerial Device to bring the operator down.

**NOTE: Oil spills may require notifying Local, State, or Federal Authorities.**



**The Aerial Device must not be operated until repairs have been completed and the Aerial Device cycled from the lower controls to purge air.**

**ENGINE FAILURE**

If the prime power source fails, the optional auxiliary let down power system can be used for emergency operation. If the auxiliary let down power system is not installed and the vehicle has a manual transmission, then use the engine stop/start control (if so equipped) to crank the engine.

**HYDRAULIC PUMP FAILURE**

If the primary hydraulic pump fails, use the auxiliary let down power system, if equipped.

**CONTROL VALVE FAILURE**

A control valve malfunction could develop in either the individual control levers or the multifunction single stick control.

If the Aerial Device motion cannot be stopped because the control valve will not return to the centered or neutral position, activate the emergency stop mode by pushing down the emergency stop. The emergency stop position will disable the boom controls, which will stop the Aerial Device's motion. If the engine stop/start control is installed, shut off the engine. The engine and the Aerial Device's motion will cease. Then manually attempt to center the spring-loaded control lever before restarting the engine. If the spring-loaded control lever at the platform will not return to neutral, the Aerial Device can be returned to a stowed position by overriding the upper controls from the lower controls.

After any emergency situation, it is the operator's responsibility to notify appropriate maintenance personnel to make sure the Aerial Device is repaired and adjusted.

Identifying the problem and initiating the recommended emergency procedures will help to minimize or possibly prevent injuries.

**OPERATIONAL LIMITATIONS****PLATFORM LEVELING SYSTEM**

The platform leveling system is designed to carry the rated load of the platform. Collision of the platform(s) with a fixed object, including the ground, or attachment of any load lifting devices to the platform(s) can damage or break the leveling system, causing the platform to be overturned. Avoidance of these hazards and use of OSHA approved fall arrest system for all personnel in the platform is essential for protection against this type of accident.



Do not allow booms or platform to make contact with fixed objects including the ground. Look for possible contact of booms or platform with fixed objects if you feel the platform is not staying level.



The platform leveling mechanism is designed to carry the rated platform capacity, applied standing over the center of the platform floor. Hoisting of material from the outer edge of the platform, from a pole attached to and extending over the top of the platform, places excessive loads on the leveling mechanism. This procedure could cause overturning of the platform(s) and ejection of personnel.



All platform occupants must wear OSHA approved fall arrest system.

**FALL ARREST**

Fall arrest is required whenever in an aerial or digger derrick platform. An OSHA compliant fall arrest system with the lanyard attached to the provided anchor at the boom tip must be used. The issue is not falling from the platform; but being ejected. You can be ejected by failure of a component causing unexpected motion, sudden release of energy from catching or snagging and releasing, or an external force on the vehicle, boom or boom tip. Perform daily inspection of your fall arrest harness and lanyard following the fall arrest manufacturer’s instructions. Retire any harness and lanyard after a fall incident.

**RESPONSE TO A FALL**

ANSI and OSHA state that no more than 6 minutes should pass from the time a worker falls to when he is reached. These time limits are to mitigate the risks of unconsciousness or further injury of the suspended worker. Each company must have a rescue plan in place to recover a suspended worker. Practice the rescue plan with all workers including the ground persons in this training, who may be the only ones available to perform the rescue. Train all employees to follow your rescue plan to recover the fallen person as quickly as safely possible without endangering the rescue personnel. Determine whether first aid is required as quickly as possible. Notify emergency services if the worker needs to be transported to the hospital according to your companies policies.

One of the dangers of being suspended in a safety harness is suspension trauma (orthostatic intolerance). Immobile workers suspended in their harness may lead to fainting or an unconscious state. Depending on the length of time, anywhere from few minutes to about 20 minutes, the suspended worker may become unconscious and depending on the level of venous pooling, the result may lead to death. Because the person will have limited ability to move their legs, blood will pool and not be available for circulation to the other parts of the body and brain. Communicate with the fallen worker to encourage them to move their arms and legs to promote blood circulation to the extremities. If the worker has signs of physical injury, or signs of suspension trauma such as; dizziness, fainting, nausea, sweating, paleness, hot flashes, increased heart rate, breathlessness, unusually low heart rate, unusually low blood pressure, or loss of vision contact emergency medical services immediately. A dangerous condition that sometimes occurs with suspension trauma is compartment syndrome. Also watch the fallen person carefully after rescue. A condition known at Reflow Syndrome can occur. The return of pooled, hypoxic blood and its metabolic byproducts from the extremities to the heart can cause medical issues even after rescue. Refer to your safety department, rescue plan, or local health providers for more information.



**STORING BOOMS FOR TRANSPORT**

The booms must be stored for transport in sequence to prevent damage to the booms. The lower boom must be lowered fully before lowering the upper boom into the boom rest.

Storing the unit:

1. Rotate the booms so the alignment marks on the pedestal line up with the mark on the turntable (if equipped) or the lower boom rest aligns.
2. Lower the lower boom fully.
3. Lower the upper boom into the rest.
4. Always tie down the upper boom in the rest.
5. Remove tools and equipment from platform and truck bed so they do not fall on roadway.
6. Install platform cover if used or ensure liner is retained in platform.



### LEAVING THE JOB SITE

1. Place upper and lower booms in the proper stored position for traveling. Upper boom must be locked in place with hold-down latch. Store booms in rests so boom deflection is removed and boom weight is supported. Do not stow lower boom so it deflects downward in the middle.

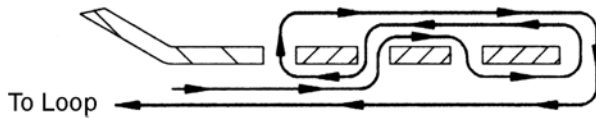
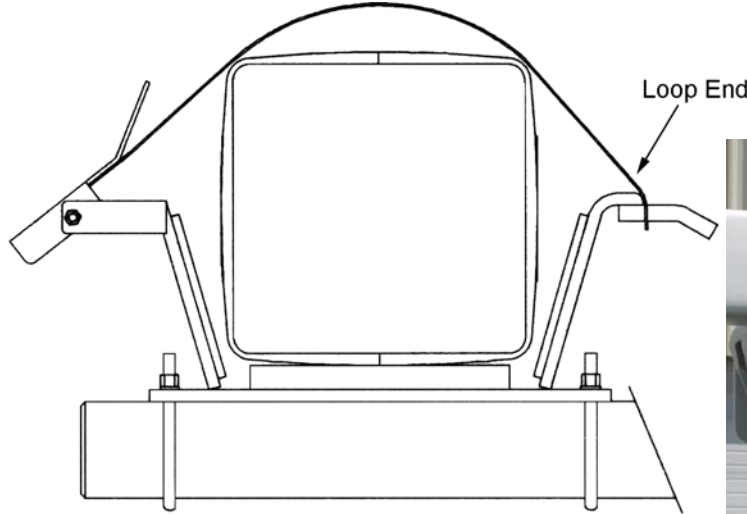

**STRAP MUST BE THREADED AS SHOWN**

 **The upper boom must be completely secured with the hold-down strap in its rest before travel. If the upper boom is allowed to bounce in its rest, the fiberglass may craze, shatter, and eventually buckle.**

2. Retract all outriggers and properly store outrigger pads and chocks.
3. Stow all loose tools and equipment.

 **Do not travel with tools or other items stored in the platform. Loose items may damage the platform or fall on the roadway during road travel. Personnel are not allowed to ride in the platform during travel.**

4. Install and secure platform cover (if equipped) or ensure liner is securely retained in platform.
5. Disengage PTO before travel to prevent damage.
6. Shut off master switch.
7. Make final inspection that everything is properly stored.
8. Turn off vehicle warning lights.
9. Disengage brakes.
10. When traveling, remember the overall height of the unit.
11. Report any operational problems during operation to qualified personnel for evaluation and repair.
12. Follow the vehicle manufacturer's instructions for operating the vehicle.
13. All personnel need to be in cab of truck while traveling.

**Drive carefully!**







## **SECTION 2**

# **MAINTENANCE GUIDELINES**

### **PREVENTATIVE MAINTENANCE**

A preventative maintenance program based on the manufacturer's recommendations shall be established. Dated and detailed inspection and repair records shall be maintained.



**Failure to inspect and maintain equipment endangers operators and crew. Not performing inspections and maintenance is false economy.**

It is recommended that the replacement parts for your Aerial Device be obtained from a Terex South Dakota, Inc. distributor or Terex South Dakota, Inc.

### **MAINTENANCE PROCEDURE**

Before maintenance, adjustments, and repairs are started the following precautions shall be taken as applicable:

- You must be authorized by owner to operate unit.
- Place vehicle where it will cause the least interference with other equipment or operations in the area.
- All controls at the off position.
- Starting means rendered inoperative.
- Warning or "OUT OF ORDER" signs placed on the vehicle.
- Power plant stopped or disconnected at power takeoff.
- Relax all hydraulic cylinders used for boom lift and articulation.
- Relieve hydraulic oil pressure from all hydraulic circuits before loosening or removing hydraulic components.

After adjustments and repairs have been made, the Aerial Device shall not be operated until all guards have been reinstalled, trapped air removed from hydraulic system, safety devices reactivated, and maintenance equipment removed.

Warning or "OUT OF ORDER" signs shall be placed and removed by authorized personnel only.

### **ADJUSTMENTS AND REPAIRS**

Any unsafe conditions disclosed by the inspection requirements of this section shall be corrected before operation of the Aerial Device is resumed. Adjustments and repairs shall be done only by qualified personnel.

Adjustments shall be maintained to assure correct functioning of components. The following are examples:

- All functional operating mechanisms.
- Safety devices.
- Control systems.
- Power plants.

Repairs or replacements shall be provided promptly as needed for safe operation. The following are examples:

- All critical parts of functional operating mechanisms which are cracked, broken, corroded, bent or excessively worn. This is for all parts of the Aerial Device, pedestal, subframe, outrigger, and attachments to the vehicle.
- All critical parts of the vehicle structure which are cracked, bent, broken or excessively corroded.
- Hooks showing damage, disclosed by "Frequent Inspection" requirements in the maintenance manual, shall be discarded. Field repairs by welding or re-shaping shall not be permitted.



All replacement parts or repairs shall have at least the original safety factor. Do not alter, modify, remove or replace any part of the Aerial Device without the approval of the manufacturer.

**NOTE: Do not use hoses having less than the working pressure for the function, see maintenance manual for specific hose requirements. Only use orange hoses marked "Non-Conductive" for hydraulic tools at the boom tip and in areas that bridge the insulation gap.**

**LUBRICATION**

All moving parts of the Aerial Device and vehicle, for which lubrication is specified, shall be regularly lubricated. Lubricating systems shall be checked for proper delivery of lubricant. Particular care should be taken to follow manufacturer’s recommendations as to points and frequency of lubrication, maintenance of lubricant levels and types of lubricant to be used.

The preferred lubes are listed in the lube chart. The following are acceptable for the Aerial Device:

1. Gun Grease: Lithium, Sodium, or Calcium base with EP additives, with no more than 5% molybdenum or graphite filled white grease. Do not use fluorocarbon based lubricants or zinc oxide filled white grease.
2. Gear Grease: If Mobil EP023 is not available, EP85W-140 can be used. More seal leakage may result because of thinner consistency.

Machinery shall be stationary while lubricants are being applied and protection provided as called for in “Maintenance Procedure”.



**The modification, rework, replacement, or substitution of any part of the Aerial Device with a means not equal to the original equipment provided by the manufacturer may cause serious personal injury.**

**GENERAL INFORMATION**

1. Keep inspection records up-to-date.
2. Record and report all discrepancies to your supervisor.
  - a. Records of frequent inspections do not need to be retained unless a discrepancy is found. In that case, a record of the discrepancy and the corrective action must be retained for five (5) years.
  - b. Periodic inspections must be dated, signed and kept for five (5) years.
3. A dirty Aerial Device and vehicle cannot be properly inspected. Keep your Aerial Device and vehicle clean!
4. Follow vehicle manufacturer’s requirements for inspection, maintenance, and repairs.
5. Only qualified personnel shall do repairs and inspections.
6. Oil spills may require notifying Local, State, or Federal Authorities.
7. A post event inspection or test is required if the unit has been overloaded, shock loaded, overturned, in an accident, experienced electrical contact or applications of unintended external force.



**The following checklists must be used daily prior to each shift, 180 days (1000 hours), 12 months (2,000 hours), 5 years (10,000 hours) and 10 years (20,000 hours). Failure to do so could endanger the life of the operator. Always remember, scheduled maintenance can save much more than it costs.**

**NOTE: The following check points listed are the minimum recommended by Terex South Dakota, Inc. They are subject to supplementation to conform with your own company regulations.**

**NOTE: Remember that the safety of all personnel and the operational efficiency of the Aerial Device are dependent upon thorough inspections and maintenance practices.**

**NOTE: Dirty or dusty conditions or unusual weather conditions may require more frequent maintenance.**



**Changes to the vehicle computer settings could affect equipment operation and could result in crushing or tip over that could cause death or serious injury.**

- Do not alter computer settings without full knowledge of affect of changes.
- See information supplied with truck manuals and contact final stage manufacturer for required settings.



## **FREQUENT AND PERIODIC INSPECTION INTERVALS**

### **DAILY, PRIOR TO EACH SHIFT**

1. Check controls at platform and lower controls for proper operation.
2. Inspect fall arrest equipment and attachments.
3. Inspect visual and audible devices.
4. Verify operation of interlocks.
5. Check cleanliness and dryness of fiberglass components.
6. Visually check for missing, damaged, or loose covers and guards.
7. Check for missing and illegible warning, operational, or instructional markings.
8. Visually check oil level in hydraulic reservoir.
9. Visually inspect for leaks in hydraulic system.
10. Visually check all cylinders for leaks.
11. Visually inspect leveling system. (Chains and Insulator Assemblies)
12. Visually inspect all pin retainers and all fasteners for tightness.
13. Visual inspection of all structural members for cracks and permanent deformation.
14. Check for rotational obstructions.
15. Visual inspection of all electrical wires.
16. Operational test of all boom functions.
17. Inspect winch line, hook, and slings.
18. Visually inspect all sprockets, chains, pulleys, and pins.
19. Repair or replace items found to be worn or damaged.

### **180 DAYS (1,000 HOURS)**

1. Inspect exposed hoses.
2. Clean hydraulic tank breather.
3. Check tightness of rotation bearing bolts, turntable to bearing, and bearing to pedestal for proper torque. (see maintenance manual)
4. Daily inspections.
5. Replace return filter. (First 180 day inspection only)
6. Check tension on leveling system.
7. Lubricate all points per lubrication chart recommendations.
8. Apply lubricant to rotation gearbox pinion and turntable bearing.

### **12 MONTHS (2,000 HOURS)**

1. Inspect and lubricate PTO drive shaft to pump.
2. Take samples of hydraulic oil and test.
3. Check all system pressure adjustments for proper setting.
4. Perform cylinder drift tests.
5. Perform structural and critical weld inspections.
6. Perform dielectric tests.
7. Visually inspect any vacuum prevention system and verify proper operation.
8. Daily and 180 days (1,000 hours) inspections.
9. Inspect leveling chain, master links, and leveling rods.
10. Replace return filter.

### **10 YEARS (20,000 HOURS)**

1. Remove leveling chain and leveling rods for inspection. Replace all chains including master links marked Hitachi 80. Inspect all other chains, and leveling rods, replace if inspection requires.
2. Daily, 180 days (1,000 hours), and 12 months (2,000 hours) inspections.

## CONTROL SYSTEM

1. Check that control handle returns to neutral when released from any position with the exception of tool detents and emergency stops.
2. Check that all movements can be made to start smoothly, without jerking or sudden motion when control handle is moved slowly.
3. Verify that no movement of the boom occurs unless the enable system is activated.

## OPERATIONAL TESTS

Perform the following tests and checks, verifying all cycle times are within the stated limits.

1. Check that boom(s) operate smoothly over full travel, without grinding, cracking, or grating.
2. Check that all movable hydraulic and control hoses operate over full range of boom and turntable movements without stretching, kinking or rubbing on sharp corners.

## ELECTRICAL TESTS

Dielectric integrity of the booms must be tested periodically. A dielectric test must also be performed if insulating components are replaced or if the insulation value is in question.



**Platform insulation must never be depended upon when operating in an electrical environment, and platform must be considered as having no insulation value without a tested and certified liner installed.**

Follow dielectric test specifications as prescribed by ANSI A92.2 for proper test procedure for the classification of unit being tested. See Maintenance Manual for proper dielectric testing.

## POST EVENT INSPECTION AND TEST

After any event where the aerial is subject to excessive loading or stress such as; overturning, unintended external mechanical or electrical forces, shock loading or overload, the aerial device shall be removed from service and a periodic inspection performed. In addition to the periodic inspection other non-destructive inspection procedures may be required to detect possible structural damage. All damaged items shall be replace or repaired before the unit is returned to service. Return to service shall be approved by a qualified person and the inspection and repair information recorded and retained.

**LUBRICATION CHART**



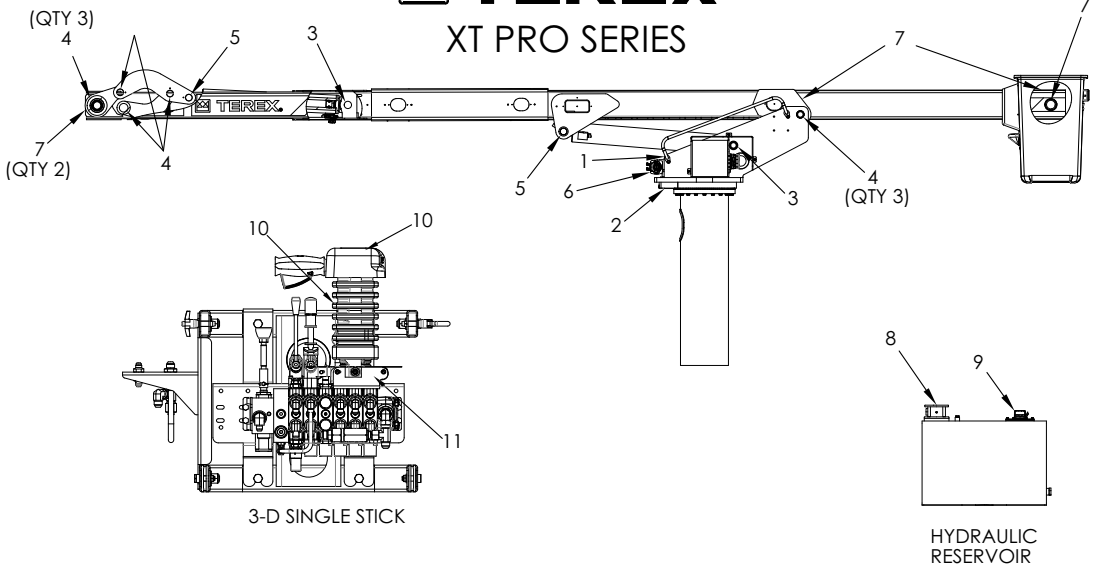

3-D SINGLE STICK

HYDRAULIC RESERVOIR

ITEM	LUBRICATION POINT		LUBRICANT RECOMMENDED	SERVICE	
				INTERVAL	METHOD
1	ROTATION BEARING	**	LITHIUM-BASE EP #2 GREASE	180 DAYS 1000 HRS	GREASE GUN
2	ROTATION GEAR TEETH				
3	CYL. BALL BUSHINGS				
4	PIVOT BUSHINGS				
5	CYL. BUSHINGS				
6	ROTATION SPEED REDUCER		MOBILUX® EP 023	180 DAYS 1000 HRS	+ FILL IF LOW
7	CHAINS		NON-DETERGENT SAE 30	180 DAYS 1000 HRS	BRUSH
8	RETURN LINE FILTER		SEE MAINTENANCE MANUAL		
9	HYDRAULIC RESERVOIR	*	PREMIUM ISO 15 HYDRAULIC FLUID	DAILY	+ FILL IF LOW
10	CONTROL HANDLE PIVOTS		LUBRICATING OIL	AS REQ'D.	SPRAY
11	VALVE LINKAGE				
12	BASKET SHAFT				

USE THE ABOVE PRODUCTS OR EQUIVALENT:

+ ALWAYS DRAIN AND REFILL WHEN DISASSEMBLED OR REBUILT.

NOTE: ALL MOVING PARTS NOT EQUIPPED WITH GREASE FITTINGS SHOULD BE LUBRICATED WITH A PENETRATING TYPE LUBRICANT AS REQUIRED.

DUSTY AND DIRTY CONDITIONS WILL REQUIRE MORE FREQUENT LUBRICATION.

\* DRAIN & FILL WHEN CONTAMINATED.

\*\* LUBRICATE SPARINGLY EVERY 1/8 REVOLUTION, FOR TWO REVOLUTIONS IF UNIT HAS CONTINUOUS ROTATION.

FOR COLD WEATHER APPLICATIONS:  
USE AIRCRAFT HYDRAULIC FLUID  
MIL-5606A - SEE MANUAL FOR PROPER FLUID SELECTION.

611901B

## STORAGE PROCEDURE

When a unit will not be used for a period of time, it should be prepared for storage to reduce the deteriorating effects of the environment. This includes the following:

- Wash and clean to remove accumulated road grime. It can discolor the paint if left on for long periods of time.
- Clean and wax the fiberglass components. If storage is in the sun, cover the booms.
- Clean and coat the exposed cylinder rods with grease, preservative spray or heavy preservative oil.
- Clean and grease the exposed valve spools and linkage.
- Lubricate the entire Aerial Device following the lube chart.
- Check the oil for pH level and water content. Acidic oil or water in the oil may settle out during storage and can rust the interior of the hydraulic system.
- Cover the platform to prevent water from accumulating. A platform full of water can weigh over 900 lbs. (408 kg) and exceed the capacity of the platform.
- Ensure the hydraulic tank filler-breather filter is intact to prevent dirt entering the tank when the temperature changes.
- Grease all sliding surfaces where there is metal contact to prevent rust.
- Touch up any bare metal and where the paint is chipped or cracked.
- Spray the electric collector commutators with LPS 1 or CRC 5-56 to prevent corrosion of the surface.
- Service the truck as recommended by the manufacturer.

**NOTE: The period of time between uses when the unit should be prepared for storage varies with the location. If the climate is temperate and dry it may be 4 months. If it is in a humid area next to the ocean with the salt air it may be only 2 weeks. Cylinders which are not cycled fully in normal use must be cycled through a full stroke weekly to maintain an oil film on the exposed rod surface.**

## RETURNING TO SERVICE

Perform the 180 day inspection upon returning the unit to service after storage.



# APPENDIX - A

## STANDARDS AND REGULATIONS

In addition to the operational instructions provided herein, various standards and governmental regulations must be followed in the use and operation of your Terex South Dakota, Inc. unit.

### ANSI STANDARDS

ANSI standards that are applicable to the operation and maintenance of your unit:

1. ANSI A92.2 (latest revision) Vehicle Mounted Elevating and Rotating Aerial Devices,
2. ANSI A10.31 (latest revision) Digger Derricks - Safety Requirements, Definitions and Specifications (A partial extraction is included in this appendix),
3. ANSI C2, Part 4 (latest revision) (National Electric Safety Code®) Rules for the Operation of Electric Supply and Communication Lines and Equipment,
4. ANSI Z133.1 (latest revision) Safety Requirements for Tree Pruning, Trimming, Repairing, or Removal.

For complete, current copies of ANSI standards, you must annually write to the following:

American National Standards Institute  
11 West 42nd Street  
New York, NY 10036

Copies of the standards can also be found on the Internet at:

[www.ansi.org](http://www.ansi.org)

### OSHA REGULATIONS

OSHA regulations that are applicable to the operation and maintenance of your unit:

1. OSHA Subpart V, Power Transmission and Distribution,
2. OSHA 1910.67, Vehicle Mounted Elevating and Rotating Cable Placers,
3. OSHA 1910.268, Telecommunications,
4. OSHA 1910.269, Electrical Power Generation, Transmission and Distribution,
5. OSHA Subpart M, Fall ,
6. OSHA 1910.147, The Control Of Hazardous Energy (Lockout/Tagout),
7. OSHA Subpart S, Electrical,
8. OSHA 1910.333, Selection and use of work practices.
9. OSHA Subpart CC, - Cranes and Derricks in Construction

For complete, current copies of OSHA regulations, you must annually write to the following or contact your OSHA Regional Office.

Technical Data Center  
Frances Perkins Department Of Labor Building  
Room N2439  
200 Constitution Avenue  
Washington, DC 20210

Copies of the standards can also be found on the Internet at:

[www.osha.gov](http://www.osha.gov)

These are not all inclusive of the applicable codes, standards, or regulations. It is your responsibility and your employer's responsibility to identify and comply with applicable codes, standards and regulations.

The information provided herein is accurate as of the date your Terex South Dakota, Inc. unit was manufactured. You must comply with the codes, standards and regulations as they are updated over time. It is your employer's responsibility to obtain copies and comply with all standards and regulations.



**OSHA EXCERPTS: (CLEARANCE DISTANCE)**

The following are excerpts from OSHA Standards. They are not complete and do not cover all safety work rules. Refer to the most current version of OSHA regulations available at [www.osha.gov](http://www.osha.gov) for any changes since this manual was printed.

**PARTIAL EXCERPT FROM SUBPART S - ELECTRICAL: (02-01-1998 EDITION)**

1910.333 Selection and use of work practices.

(c), (i) Unqualified person.

(A) When an unqualified person is working in an elevated position near overhead lines, the location shall be such that the person and the longest conductive object he or she may contact cannot come closer to any unguarded, energized overhead line than the following distances:

1. For voltages to ground 50kV or below - 10 feet (3.05 m);
2. For voltages to ground over 50kV - 10 feet (3.05 m) plus four inches (101.6 mm) for every 10kV over 50kV.

(B) When an unqualified person is working on the ground in the vicinity of overhead lines, the person may not bring any conductive object closer to unguarded, energized overhead lines than the distances given in paragraph (c)(3)(i)(A) of this section.

**NOTE: For voltages normally encountered with overhead power line, objects which do not have an insulating rating for the voltage involved are considered to be conductive.**

**EXCERPT FROM OSHA SUBPART V - POWER TRANSMISSION AND DISTRIBUTION (11-14-1990 EDITION)**

1926.950 General Requirements (c) Clearances. The provisions of paragraph (1) or (2) of this section shall be observed.

(1) No employee shall be permitted to approach or take any conductive object without an approved insulating handle closer to exposed energized parts than shown in Table R-6, unless:

- (i) The employee is insulated or guarded from the energized part (gloves or gloves with sleeves rated for the voltage involved shall be considered insulation of the employee from the energized part), or
- (ii) The energized part is insulated or guarded from him and any other conductive object at different potential, or
- (iii) The employee is isolated, insulated, or guarded from any other conductive object(s), as during live-line bare-hand work.

(2)(i) The minimum working distance and minimum clear hot stick distances stated in Table R-6 shall not be violated. The minimum clear hot stick distance is that for the use of line-line tools held by lineman when performing live-line work. (e)(15) The minimum clearance distances for live-line bare-hand work shall be as specified in Table R-7. These minimum clearance distances shall be maintained from all grounded objects and from lines and equipment at a different potential than that to which the insulated Cable Placer is bonded unless such grounded objects or other lines and equipment are covered by insulated guards. These distances shall be maintained when approaching, leaving and when bonded to the energized circuit.

**1926.960(c)(1)(i)**

The employer shall establish minimum approach distances no less than the distances computed by Table V-2 for ac systems or Table V-7 for dc systems.

**1926.960(g)(2)**

Estimate of available heat energy. For each employee exposed to hazards from electric arcs, the employer shall make a reasonable estimate of the incident heat energy to which the employee would be exposed.

**1926.960(g)(3)**

Prohibited clothing. The employer shall ensure that each employee who is exposed to hazards from flames or electric arcs does not wear clothing that could melt onto his or her skin or that could ignite and continue to burn when exposed to flames or the heat energy estimated under paragraph (g)(2) of this section.





NOMINAL VOLTAGE (KV) (PHASE TO PHASE)	DISTANCE			
	PHASE-TO-GROUND EXPOSURE		PHASE-TO-PHASE EXPOSURE	
	M	FT	M	FT
0.050 TO 0.300 <sup>2</sup>	AVOID CONTACT		AVOID CONTACT	
0.301 TO 0.750 <sup>2</sup>	0.33	1.09	0.33	1.09
0.751 TO 5.0	0.63	2.07	0.63	2.07
5.1 TO 15.0	0.65	2.14	0.68	2.24
15.1 TO 36.0	0.77	2.53	0.89	2.92
36.1 TO 46.0	0.84	2.76	0.98	3.22
46.1 TO 72.5	1.00	3.29	1.20	3.94
<p>1. Employers may use the minimum approach distances in this table provided the worksite is at an elevation of 900 meters (3,000 feet) or less. If employees will be working at elevations greater than 900 meters (3,000 feet) above mean sea level, the employer shall determine minimum approach distances by multiplying the distances in this table by the correction factor in Table R-5 corresponding to the altitude of the work.</p> <p>2. For single-phase systems, use voltage-to-ground.</p>				

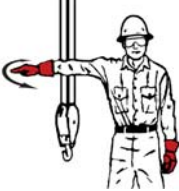



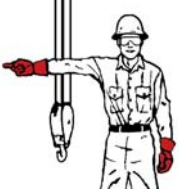

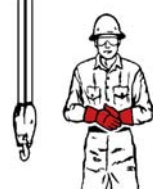

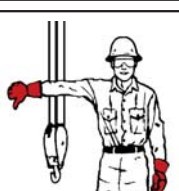

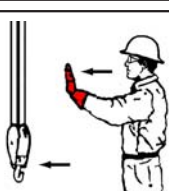

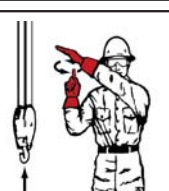
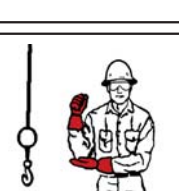



TABLE R-6 - ALTERNATIVE MINIMUM APPROACH DISTANCES FOR VOLTAGES OF 72.5 KV AND LESS

VOLTAGE RANGE PHASE TO PHASE (KV)	PHASE-TO-GROUND EXPOSURE		PHASE-TO-PHASE EXPOSURE	
	M	FT	M	FT
72.6 TO 121.0	1.13	3.71	1.42	4.66
121.1 TO 145.0	1.30	4.27	1.64	5.38
145.1 TO 169.0	1.46	4.79	1.94	6.36
169.1 TO 242.0	2.01	6.59	3.08	10.10
242.1 TO 362.0	3.41	11.19	5.52	18.11
362.1 TO 420.0	4.25	13.94	6.81	22.34
420.1 TO 550.0	5.07	16.63	8.24	27.03
550.1 TO 800.0	6.88	22.57	11.38	37.34
<p>1. Employers may use the minimum approach distances in this table provided the worksite is at an elevation of 900 meters (3,000 ft) or less. If employees will be working at elevations greater than 900 meters (3,000 feet) above mean sea level, the employer shall determine minimum approach distances by multiplying the distances in this table by the correction factor in Table R-5 corresponding to the altitude of the work.</p> <p>2. Employers may use the phase-to-phase minimum approach distances in this table provided that no insulated tool spans the gap and no large conductive object is in the gap.</p> <p>3. The clear live-line tool distance shall equal or exceed the values for the indicated voltage ranges.</p>				

TABLE R-7 ALTERNATIVE MINIMUM APPROACH DISTANCES FOR VOLTAGES OF MORE THAN 72.5 KV

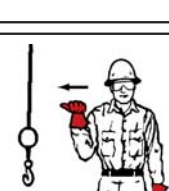

**STANDARD HAND SIGNALS**

 <p><b>STOP.</b> With arm extended horizontally to the side, palm down, arm is swung back and forth.</p>	 <p><b>EMERGENCY STOP.</b> With both arms extended horizontally to the side, palms down, arms are swung back and forth.</p>	 <p><b>HOIST.</b> With upper arm extended to the side, forearm and index finger pointing straight up, hand and finger make small circles.</p>	 <p><b>RAISE BOOM.</b> With arm extended horizontally to the side, thumb points up with other fingers closed.</p>	
 <p><b>SWING.</b> With arm extended horizontally, index finger points in direction that boom is to swing.</p>	 <p><b>RETRACT TELESCOPING BOOM.</b> With hands to the front at waist level, thumbs point at each other with other fingers closed.</p>	 <p><b>RAISE THE BOOM AND LOWER THE LOAD.</b> With arm extended horizontally to the side and thumb pointing up, fingers open and close while load movement is desired.</p>	 <p><b>DOG EVERYTHING.</b> Hands held together at waist level.</p>	 <p><b>LOWER.</b> With arm and index finger pointing down, hand and finger make small circles.</p>
 <p><b>LOWER BOOM.</b> With arm extended horizontally to the side, thumb points down with other fingers closed.</p>	 <p><b>EXTEND TELESCOPING BOOM.</b> With hands to the front at waist level, thumbs point outward with other fingers closed.</p>	 <p><b>TRAVEL/TOWER TRAVEL.</b> With all fingers pointing up, arm is extended horizontally out and back to make a pushing motion in the direction of travel.</p>	 <p><b>LOWER THE BOOM AND RAISE THE LOAD.</b> With arm extended horizontally to the side and thumb pointing down, fingers open and close while load movement is desired.</p>	 <p><b>MOVE SLOWLY.</b> A hand is placed in front of the hand that is giving the action signal.</p>
 <p><b>USE AUXILIARY HOIST (WHIPLINE).</b> With arm bent at elbow and forearm vertical, elbow is tapped with other hand. Then regular signal is used to indicate desired action.</p>	 <p><b>CRAWLER CRANE TRAVEL, BOTH TRACKS.</b> Rotate fists around each other in front of body; direction of rotation away from body indicates travel forward; rotation toward body indicates travel backward.</p>	 <p><b>USE MAIN HOIST.</b> A hand taps on top of the head. Then regular signal is given to indicate desired action.</p>	 <p><b>CRAWLER CRANE TRAVEL, ONE TRACK.</b> Indicate track to be locked by raising fist on that side. Rotate other fist in front of body in direction that other track is to travel.</p>	 <p><b>TROLLEY TRAVEL.</b> With palm up, fingers closed and thumb pointing in direction of motion, hand is jerked horizontally in direction trolley is to travel.</p>

**NOTE: Not all signals can be used on Digger Derricks or Aerial Devices. Method of signaling must be agreed upon by ground person and operator before work begins.**

# APPENDIX - B

## RESPONSIBILITIES

**ANSI A92.2-2015** became effective June 2016. It became the responsibilities of Dealers and Installers, Owners, Users, Operators, Lessors or Lessees, and Brokers to follow the requirements of this standard after June 2016, regardless of the date of manufacture.

### ANSI A92.2-2015 (PARTIAL)

**Table of Contents:**

7.	Responsibilities of Dealers and Installers.	B - 1
8.	Responsibilities of Owners.	B - 2
9.	Responsibility of Users.	B - 5
10.	Responsibilities of Operators.	B - 7
11.	Responsibilities of Lessors or Lessees.	B - 9
12.	Responsibilities of Brokers.	B - 10

## 7. RESPONSIBILITIES OF DEALERS AND INSTALLERS.

**7.1 General Responsibilities.** Each dealer or installer as applicable shall comply with the requirements of this section.

**7.2 Vehicle Specifications.** Each dealer or installer, or both, who sells an aerial device shall inform the owner or user, or both, of the manufacturer’s minimum vehicle specifications.

**7.3 Vehicle Weight Distribution.** The installer shall be responsible for the weight distribution of the completed mobile unit (MEWP) in accordance with the requirements of the aerial device and the applicable regulations. Allowance shall be made for the weight of readily removable tools and material specified by the user.

**7.4 Manuals.** Upon delivery of the equipment to the owner or user, the dealer or installer shall provide the manuals as required by Paragraph 6.4 of this standard and manuals for auxiliary equipment added by the installer.

**7.5 Installations.** The installer shall comply with Sections 5 and 6 of this standard relating to proper installation and shall follow the instructions of the manufacturer. In the event the original manufacturer no longer exists, an equivalent entity may provide these instructions. The installer shall maintain access to the lower controls as described in section 4.3.3. The installer of the aerial device shall, before the mobile unit (MEWP) is placed in operation, perform stability tests in accordance with the requirements of 4.5.1 and 4.5.2, the operational and visual tests in accordance with the requirements of 6.6.1 and 6.6.2, and the appropriate electrical tests required in 5.4 of this standard. For insulating aerial devices, the installer shall assure conformance to the Qualification test requirements of 5.3.2 by either obtaining a certification of the test and performing a periodic test after installation, or by performing the Qualification test. The installer shall, when installing an aerial device on a chassis which is a highway vehicle, comply with all requirements of the applicable Federal Motor Vehicle Safety Standards in effect at the time of installation. Certification as a manufacturer (alteration, intermediate or final) of a motor vehicle under the Federal Motor Vehicle Safety Standards is required. The travel height of the mobile unit (MEWP) shall be posted in a location that is readily visible to the vehicle operator.

**7.5.1 Locking Pins.** Any locking pins shall be secured against unintentional disengagement and loss.

**7.5.2 Unauthorized Use.** Mobile Units (MEWPs) shall be equipped with a device to prevent unauthorized use.

### 7.6 Ingress/Egress

**7.6.1 Steps/Ladders.** Distance between the ground or lower platform surface to the top surface of the first step should not exceed 27 inches where possible. Distance between the top surface of steps or rungs should not exceed 16 inches where possible. Each step or rung should have a minimum width of 6 inches for placement of one foot or 12 inches for placement of two feet and minimum rung diameter of 1 inch.



**7.6.2 Access Opening/Passage.** Access opening/passage should have a minimum width of 18 inches and minimum opening height of 30 inches.

**7.6.3 Three Point Support.** Steps or ladders whose inclined angle from horizontal is greater than 50 degrees should incorporate supports that would permit a person to use simultaneously two hands and one foot or two feet and one hand for support while ascending or descending.

**7.7 Quality Assurance.** The installer shall have a documented quality assurance program that will ensure compliance with this standard.

**7.8 Weldings.** All welds made by the installer, whose failure could result in motion of the platform(s) shall meet the Structural Welding Code AWS D1.1-2006 and AWS D1.2-2003. The installer shall establish applicable welding quality assurance procedures for all weldments.

**7.9 Training.** The dealer or installer shall offer training or training materials that aid owners, users, lessors and lessees in the operation, inspection, testing and maintenance of the aerial device. This training shall be offered initially and subsequently on request.

**7.9.1 Dealer or Installer as User.** Whenever a dealer or installer directs personnel to operate an aerial device (inspecting, sales demonstrations, or any form of use), the dealer or installer shall assume the responsibilities of users as specified in Section 9 of this standard. All personnel authorized to operate the aerial device shall have been trained in a program that meets the requirements of this standard.

**7.10 Maintenance Training.** Dealer maintenance personnel shall be trained in inspection, testing and maintenance of the aerial device in accordance with the manufacturer's recommendations.

## 8. Responsibilities of Owners.

**8.1 General Responsibilities.** Each owner shall comply with the requirements of this section. The following responsibilities pertain to the owner's inspection, testing, maintenance, modification, training and transfer of ownership. These activities shall be performed by qualified person(s).

### 8.2 Inspection and Testing Classifications.

**8.2.1 Initial Inspection and Test.** Prior to initial use, all new or modified mobile units (MEWP) shall be inspected and tested to ensure compliance with the provisions of this standard. Certification by the manufacturer, dealer, final installer or an equivalent entity(s), meets this requirement.

**8.2.2 Regular Inspection and Tests.** The inspection procedure for mobile units (MEWP) is divided into two classifications based upon the intervals at which inspections and tests shall be performed. Intervals shall be set by the owner in accordance with the manufacturer's recommendations. Such intervals are dependent upon component function and exposure to wear, deterioration and other agents which adversely affect component life. Two classifications are designated:

- (1) Frequent Inspection and Test: Daily to monthly intervals.
- (2) Periodic Inspection and Test: One to twelve month intervals.

**8.2.3 Frequent Inspection and Test.** Items determined by the owner in accordance with the manufacturer's recommendations for each specific aerial device shall be inspected. The following inspections and tests shall be performed by the operator prior to first use at the beginning of each shift:

- (1) Conduct walk around visual inspection looking for damaged components, cracks or corrosion, excessive wear and any loose, deformed or missing bolts, pins, fasteners, locking devices and covers.
- (2) Check all controls and associated mechanisms for proper operation to include, but not limited to, the following:
  - (a) Proper operation of interlocks.
  - (b) Controls return to neutral when released and not sticking.
  - (c) Control functions and operation clearly marked.
- (3) Check visual and audible safety devices for proper operation.
- (4) Visually inspect fiberglass and insulating components for visible damage or contamination.
- (5) Check for missing or illegible operational and instructional markings.
- (6) Check hydraulic and pneumatic systems for observable deterioration and excessive leakage.
- (7) Check electrical systems related to the aerial device for malfunctions, signs of excessive deterioration, dirt and moisture accumulation.



## APPENDIX B

(8) Perform functional test to include, but not limited to, the following:

- (a) Set-up the aerial device for operation, including stabilizers.
- (b) Cycle the aerial device functions through the complete range of motion from the lower controls, except where operation through the complete range of motion would create a hazard.
- (c) Check functionality of emergency controls.

Any suspected items shall be carefully examined or tested and a determination made by a qualified person as to whether they constitute a safety hazard. All unsafe items shall be replaced or repaired before use.

**8.2.4 Periodic Inspection or Test.** An inspection of the mobile unit (MEWP) shall be performed at the intervals defined in 8.2.2 depending upon its activity, severity of service, and environment, or as specifically indicated below. (These inspections shall include the requirements of 8.2.3):

- (1) Structural members for deformation, cracks or corrosion.
- (2) Parts, such as pins, bearings, shafts, gears, rollers, locking devices, chains, chain sprockets, wire and synthetic ropes and sheaves for wear, cracks or distortion.
- (3) Hydraulic and pneumatic relief valve settings.
- (4) Hydraulic system for proper oil level.
- (5) Hydraulic and pneumatic fittings, hoses and tubing for evidence of leakage, abnormal deformation or excessive abrasion.
- (6) Compressors, pumps, motors and generators for loose fasteners, leaks, unusual noises or vibrations, loss of operating speed and excessive heating.
- (7) Hydraulic and pneumatic valves for malfunction and visible cracks in the external valve housing, leaks and sticking spools.
- (8) Visually inspect any vacuum prevention systems and verify function of such systems.
- (9) Hydraulic and pneumatic cylinders and holding valves for malfunction and visible damage.
- (10) Hydraulic and pneumatic filters for cleanliness and the presence of foreign material in the system indicating other component deterioration.
- (11) Electrical systems and components for deterioration or wear including those not readily visible on a frequent inspection.
- (12) Performance test of all boom movements.
- (13) Condition and tightness of bolts and other fasteners in accordance with the manufacturer's recommendation.
- (14) Welds, as specified by the manufacturer.
- (15) Legible and proper identification, operational and instructional markings.
- (16) If the aerial device is rated as an insulating device, the electrical insulating components and system(s) shall be thoroughly inspected for lack of cleanliness and other conditions that compromise insulation. Then these components and system(s) shall be tested for compliance with the rating of the aerial device in accordance with one of the applicable methods and procedures as outlined in Section 5.4.3 of this standard:
  - (a) If the aerial device is used for AC bare-hand work, the before use tests outlined in 5.4.3.1 (11) (c) may be relied upon when performed quarterly, however the unit shall undergo an AC voltage test at least every three years in accordance with Table 2 criteria;
  - (b) If the aerial device is used for DC bare-hand work, the "in the field" tests outlined in 5.4.3.1 (11) (c) may be relied upon when performed quarterly, however the unit shall undergo an appropriate DC over voltage test at least every three years;
  - (c) After repair or replacement of any component that crosses the insulating system(s), or the repair or replacement of an insulating component(s), (e.g., hoses, leveling rods, boom coating, etc.), the unit shall be dielectrically tested in accordance with Section 5.4.3;
  - (d) An insulated replacement boom shall be tested to ensure conformance to 5.3.3 by the supplier;
  - (e) Bare-hand work units shall be tested for the applicable unit rating in accordance with Table I (or appropriate DC test for units used on direct current lines, see Appendix B) after any major repair to the insulating boom or any insulating boom replacement. Major repair to the insulating boom shall include resurfacing or repainting of the exterior or interior boom surfaces. The removal and subsequent reinstallation of a gradient control device is not considered a "major repair" provided proper reinstallation





of the gradient control device is performed by a qualified person in accordance with the manufacturer's instructions.

(17) If the aerial device has upper controls equipped with high electrical resistance components and the manufacturer so indicates, they shall be maintained as high electrical resistance components and should be electrically tested per 5.4.3.6.

Any suspected items shall be carefully examined or tested and a determination made by a qualified person as to whether they constitute a safety hazard. All unsafe items shall be replaced or repaired before use.

**8.2.5 Post Event Inspection or Test.** After any event during which structural members of an aerial device or mobile unit (MEWP) are suspected of being subjected to excessive loading or stress such as overturning of the mobile unit (MEWP) or application of unintended external mechanical or electrical forces to the aerial device, the aerial device shall be removed from service and subjected to the applicable periodic inspection requirements in 8.2.4. In addition to the periodic inspection, supplemental non-destructive examination procedures or other tests to assist in detecting possible structural damage to the aerial device may be required. All damaged items shall be replaced or repaired before the unit is returned to service. Return to service shall be approved by a qualified person.

### 8.3 Inspection and Test Records.

**8.3.1 Frequent.** Items to be inspected shall be designated to the operator or other authorized person making frequent inspections. Records of frequent inspections need not be made. However, where a safety hazard is found, it shall be reported in writing to a person responsible for the corrective action and that report and a record of the correction shall be maintained for five years, or as required by applicable regulations. (Appropriately archived electronic, dated and signed records meet this requirement.)

**8.3.2 Periodic.** Written, or appropriately archived electronic, dated and signed reports and records shall be made of periodic inspections and tests and retained for a period of five years or as required by applicable regulations. The Periodic Electrical Test required under Section 5.3.4 shall be documented by the entity performing such, with a report provided to the owner and a placard indicating proof of test applied to the MEWP.

**8.4 Maintenance.** Maintenance and frequency of maintenance shall be determined by the owner in accordance with the manufacturer's recommendations.

**8.4.1 Maintenance Training.** The owner shall train their maintenance personnel in inspection and maintenance of the aerial device in accordance with the manufacturer's recommendations and Section 8 of this standard.

**8.4.2 Welds.** Welding repairs of components or welds, designated as critical in the manufacturer's manual shall be made in accordance with the manufacturer's recommendations and shall meet the Structural Welding Code AWS D1.1-2006 or AWS D1.2-2003. Should the original manufacturer no longer exist, and equivalent entity may determine the required procedure.

**8.5 Modifications.** No modifications or additions which affect the stability, mechanical, hydraulic, or electrical integrity or the safe operation of the aerial device shall be made without the written approval of the manufacturer. If such modifications or changes are made, the capacity, operation and maintenance instruction markings shall be changed accordingly. In no case shall the safety factors be reduced below those specified in this standard or below the manufacturers design safety factors, whichever are greater. Should the original manufacturer no longer exist, an equivalent entity may approve required modification.

**8.5.1 Alterations.** Altering or disabling the function of safety devices, guards, or interlocks, if so equipped, is prohibited.

**8.5.2 Overriding Safety Devices.** Overriding of safety devices is prohibited, whether during normal operation or rescue, except in accordance with the manufacturer's prescribed safety override procedures. The overriding of safety devices during the testing, repair, or maintenance of an aerial device shall be carried out in accordance with the manufacturer's recommendations and procedures. Procedures for overriding safety devices shall be designed to minimize the possibility that an unsafe condition could exist.

**8.6 Weight Distribution.** Changes in loading or additions made to the mobile unit (MEWP) after the final acceptance that affect weight distribution shall meet applicable regulations by governmental agencies. In no case shall axle loads of the fully loaded vehicle exceed the Gross Axle Weight Ratings (GAWR) assigned by the manufacturer. **Note: Any change in weight distribution may adversely affect stability.**

## APPENDIX B

**8.7 Transfer of Ownership.** When a change in ownership of an aerial device occurs, it shall be the responsibility of the seller to provide the manufacturer's manual(s) for that aerial device to the purchaser. It is the responsibility of the purchaser to notify the manufacturer of the unit model and serial number and the name and address of the new owner within 60 days. If the owner uses other entities as agents (e.g., Brokers) for the sale or the arrangement of a sale of an aerial device(s) their responsibilities under this section continue.

**8.8 Markings.** The markings on the aerial device shall not be removed, defaced, or altered. All missing or illegible markings shall be promptly replaced.

**8.9 Parts.** When parts or components are replaced they shall be identical in specification and function to the original aerial device parts or components or shall provide an equal or greater factor of safety.

**8.10 Safety Bulletins.** Owners shall comply with safety related bulletins as received from the manufacturer, dealer or installer.

**8.11 Manuals.** The owner shall ensure that the operating manual(s) is stored on the mobile unit (MEWP).

**8.12 Training, Retraining and Familiarization of Operators.**

**8.12.1 General Training.** Only personnel who have received general instructions regarding the inspection, application and operation of aerial devices, including recognition and avoidance of hazards associated with their operation, shall operate an aerial device. Such items covered shall include, but not necessarily be limited to, the following issues and requirements:

- (1) The purpose and use of manuals.
- (2) That operating manuals are an integral part of the aerial device and must be properly stored on the vehicle when not in use.
- (3) A pre-start inspection.
- (4) Responsibilities associated with problems or malfunctions affecting the operation of the aerial device.
- (5) Prohibition of overriding safety devices except as approved by the manufacturer (see 8.5.2).
- (6) That secondary operating systems shall not be used for purposes other than test or recovering the work platform.
- (7) Factors affecting stability.
- (8) The purpose of placards and decals.
- (9) Workplace inspection.
- (10) Applicable safety rules and regulations, such as Part 4, ANSI C2-2007, National Electrical Safety Code (applies to utility workers as defined in ANSI C2). The above standard is an example; other industries using aerial devices have safety rules pertinent to that industry.
- (11) Authorization to operate.
- (12) Securing the aerial device and mobile unit (MEWP) from unauthorized use.
- (13) Operator warnings and instructions.
- (14) Proper use of personal fall equipment. Fall systems criteria and practices are covered in 29 CFR 1926.502.
- (15) Actual operation of the Aerial Device. Under the direction of a qualified person, the trainee shall operate the aerial device for a sufficient period of time to demonstrate proficiency in the operation of all control functions of the aerial device and safe use at operating height and reach.
- (16) Stowing the aerial device for transport and precautions related to moving the mobile unit (MEWP).

**8.12.2 Retraining.** The operator shall be retrained, when so directed by the user, based on the following:

- (1) The user's observation and evaluation of the operator. This evaluation of the operator shall include evaluating the operator's proficiency of operating the aerial device in a safe manner.
- (2) After an accident or near miss while operating an aerial device.

**8.12.3 Familiarization.** When an operator is directed to operate an aerial device they are not familiar with, the operator, prior to operating, shall be instructed regarding the following items:

- (1) The location of the manuals.
- (2) The manufacturer's warnings and instructions.



- (3) The purpose and function of all controls.
- (4) Safety devices and operating characteristics specific to the aerial device.

The operator shall operate the aerial device for a sufficient period of time to achieve proficiency in the actual operation of the aerial device.

Where authorized by the user, a qualified person may self-familiarize if the items above are completed.

**8.13 Owner as a Lessor.** When owners function as lessors, they shall have the same responsibilities as specified under Section 11 of this standard.

## 9. Responsibility of Users.

**9.1 General Responsibilities.** Each User shall comply with the requirements of this section.

**9.2 Personnel.** Only trained and authorized personnel shall be permitted to operate the aerial device.

**9.3 Training, Retraining and Familiarization of Operators.**

**9.3.1 General Training.** Only personnel who have received general instructions regarding the inspection, application and operation of aerial devices, including recognition and avoidance of hazards associated with their operation, shall operate an aerial device. Such items covered shall include, but not necessarily be limited to, the following issues and requirements:

- (1) The purpose and use of manuals.
- (2) That operating manuals are an integral part of the aerial device and must be properly stored on the vehicle when not in use.
- (3) A pre-start inspection.
- (4) Responsibilities associated with problems or malfunctions affecting the operation of the aerial device.
- (5) Prohibition of overriding safety devices except as approved by the manufacturer (see 8.5.2).
- (6) That secondary operating systems shall not be used for purposes other than test or recovering the work platform.
- (7) Factors affecting stability.
- (8) The purpose of placards and decals.
- (9) Workplace inspection.
- (10) Applicable safety rules and regulations, such as Part 4, ANSI C2-2007, National Electrical Safety Code (applies to utility workers as defined in ANSI C2). The above standard is an example; other industries using aerial devices have safety rules pertinent to that industry.
- (11) Authorization to operate.
- (12) Securing the aerial device and mobile unit (MEWP) from unauthorized use.
- (13) Operator warnings and instructions.
- (14) Proper use of personal fall equipment. Fall systems criteria and practices are covered in 29 CFR 1926.502.
- (15) Actual operation of the Aerial Device. Under the direction of a qualified person, the trainee shall operate the aerial device for a sufficient period of time to demonstrate proficiency in the actual operation of the aerial device and safe use at operating height and reach.
- (16) Stowing the aerial device for transport and precautions related to moving the mobile unit (MEWP).

**9.3.2 Retraining.** The operator shall be retrained, when so directed by the user, based on the following:

- (1) The user's observation and evaluation of the operator. This evaluation of the operator shall include evaluating the operator's proficiency of operating the aerial device in a safe manner.
- (2) After an accident or near miss while operating an aerial device.

**9.3.3 Familiarization.** When an operator is directed to operate an aerial device with which they are not familiar, they shall receive prior instruction regarding the following items:

- (1) The location of the manuals.
- (2) The manufacturer's warnings and instructions.





## APPENDIX B

- (3) The purpose and function of all controls.
- (4) Safety devices and operating characteristics specific to the aerial device.

The operator shall operate the aerial device for a sufficient period of time to achieve proficiency in the actual operation of the aerial device. Where authorized by the user, a qualified person may self-familiarize if the items above are completed.

**9.3.4 Proof of Training.** Users providing training should provide successful trainees a means to evidence their training and should provide such proof if requested by the trainee. The document evidencing training shall include the following information:

- (1) Name of trainee.
- (2) Name of entity providing training or retraining.
- (3) Name of trainer(s).
- (4) Clear identification of the make(s) and model(s) of the mobile unit (MEWP)(s) on which the operator has been trained.
- (5) The date of training.
- (6) The specific period of time the training is valid.

**9.3.5 Record Keeping.** Records of the person(s) trained in the operation of an aerial device should be retained by the training entity. These records should be retained for at least the period of time the training is valid.

**9.4 Application.** The employer and authorized operator(s) shall ensure that the aerial device is used only for intended applications as defined in the operating manual and that all recognized safety practices are observed. The aerial device shall not be operated while the mobile unit is positioned on trucks, trailers, railway cars, floating vessels, scaffolds, or similar equipment unless the application is approved in writing by the manufacturer or a qualified person.

**NOTE: The User is directed to Appendix C for guidance as to appropriate applications.**

**9.5 Electrical Hazard.** All applicable safety related work practices intended to protect from electrical hazards shall be defined and explained to the operator by a qualified person. The operator shall maintain the appropriate Minimum Approach Distance (MAD) from energized conductors and apparatus commensurate with the operator's qualification. See Appendix F for the information on the Minimum Approach Distances and other precautions.

**9.6 Bare-Hand Work.** For bare-hand work, a Category A aerial device shall be used.

**9.7 Lower Controls.** The lower controls of aerial devices shall not be used with personnel in the platform except for operator rescue or platform recovery.

**9.8 Manufacturer's Safety Bulletins.** The user shall comply with the applicable safety-related bulletins as received from the manufacturer, installer, dealer or owner.

## 10. Responsibilities of Operators.

**10.1 General Responsibilities.** Each operator shall comply with the requirements of this section.

**10.2 Personnel.** Only trained, familiarized, and authorized personnel shall be permitted to operate the aerial device.

**10.3 Operation.** During operation of the aerial device.

- (1) The operator shall make decisions on the use and operation of the aerial device with due consideration for the fact that their own safety as well as the safety of others is dependent on those decisions.
- (2) The operator shall immediately report to an authorized person (or supervisor) any safety related problem(s) or malfunction(s) that become evident. The operator shall ensure all problems and malfunctions that affect the safety of operations are repaired prior to continued use.
- (3) All platform occupants shall use appropriate fall connected to the aerial device anchorage(s).

**10.4 Work Platform.** Personnel shall maintain a firm footing on the platform floor while working thereon. Climbing by occupants on the mid-rail or top-rail of the work platform is prohibited. The occupant shall not use railings, planks, ladders, or any other device in or on the work platform for achieving additional working height or reach.



**10.5 Brakes.** The vehicle parking brake(s) shall be set at all times that the boom is elevated except when the aerial device is being used in accordance with 10.11.

**10.6 Loading.**

(1) Any loading which includes a horizontal load shall be avoided unless the mobile unit is designed for that application.

(2) Adding material or personnel loads at height may be done provided the manufacturer of the aerial device being used does not prohibit such activities. The addition of such loads shall not exceed the rated capacity for the configuration being used. Note: Load sensing systems may not provide in these situations.

**10.6.1 Vacating or Entering an Elevated Aerial Device.** Personnel shall only vacate or enter a raised aerial platform if not prohibited by the manufacturer and by complying with current OSHA regulations and IEEE 1307 standard for transferring from an elevated platform to a structure.

**10.6.2 Carrying Materials Larger than the Platform.** The operator shall ensure that only properly secured and distributed tools and materials which can be handled by a person(s) working from the platform, shall be moved. Such operations shall be performed in accordance with the manufacturer's instructions and limits.

**10.7 Alterations.** Altering or disabling the function of safety devices, guards, or interlocks if so equipped, is prohibited.

**10.7.1 Overriding Safety Devices.** Overriding of safety devices is prohibited, whether during normal operation or rescue, except in accordance with the manufacturer's prescribed safety override procedures. The overriding of safety devices during the testing, repair, or maintenance of an aerial device shall be carried out in accordance with the manufacturer's recommendations and procedures. Procedures for overriding safety devices shall be designed to minimize the possibility that an unsafe condition could exist.

**10.8 Observations.** Observations during operation for any malfunctions shall be conducted on an ongoing basis.

**10.8.1 Pre-start Inspection.** Items determined by the owner in accordance with the manufacturer's recommendations for each specific aerial device shall be inspected prior to each day's operation. The following tests and inspections shall be performed by the operator once daily, prior to first use:

(1) Conduct walk around visual inspection, looking for damaged components, cracks or corrosion, excessive wear and any loose, deformed or missing bolts, pins, fasteners, locking devices and covers.

(2) Check all controls and associated mechanisms for proper operation to include, but not limited to, the following:

- (a) Proper operation of interlocks.
- (b) Controls return to neutral when released and not sticking.
- (c) Control functions and operation clearly marked.

(3) Check visual and audible safety devices for proper operation per the manufacturer's requirements.

(4) Visually inspect fiberglass and other insulating components for visible damage and contamination.

(5) Check for missing or illegible operational and instructional markings.

(6) Check hydraulic or pneumatic systems for observable deterioration and excessive leakage.

(7) Check electrical systems related to the aerial device for malfunction, signs of excessive deterioration, dirt and moisture accumulation.

(8) Perform functional test to include, but not limited, to the following:

- (a) Set-up aerial device for operation, including stabilizers.
- (b) Cycle each aerial device boom function through its complete range of motion from the lower controls, except where operation through the complete range of motion would create a hazard.
- (c) Check functionality of emergency controls.

Any suspected items shall be carefully examined or tested and a determination made by a qualified person as to whether they constitute a safety hazard. All unsafe items shall be replaced or repaired before use.

**10.8.2 Transporting.** The aerial device, including its stabilizers, if so equipped, shall be in the manufacturer's recommended configuration when being transported.



## APPENDIX B

**10.9 Worksite.** Before the aerial device is used the worksite shall be surveyed for hazards such as:

- (1) Insufficient supporting surfaces such as soft ground or tamped earth fills.
- (2) Ditches.
- (3) Excessive slopes, drop-offs, curbs, and floor obstructions.
- (4) Debris.
- (5) Overhead obstructions and electrical conductors.
- (6) Weather conditions.
- (7) Presence of unauthorized persons.
- (8) Road or worksite traffic.
- (9) Subsurface chambers such as underground utility components or septic systems.
- (10) Hazardous locations and environments.

**10.10 Precautions.** Before and during each use the operator shall:

- (1) Check for overhead obstructions and electrical conductors.
- (2) Maintain adequate clearance from obstructions and electrical apparatus.
- (3) Ensure that the load and its distribution on the platform and/or load lifting device is in accordance with the manufacturer's requirements.
- (4) Ensure that outriggers and stabilizers are used if the manufacturer's instructions require their use.
- (5) Ensure that guardrails are properly installed, and the gates are closed.
- (6) Use outrigger pads when necessary to provide firm footing.
- (7) Cease operation of the aerial device and request further information from the user should the operator encounter any suspected malfunction of the aerial device or any hazard or potentially unsafe condition.
- (8) If the platform or elevating assembly becomes caught, snagged, or otherwise prevented from normal motion by external obstacles such that control reversal does not free the platform, all personnel should be removed from the platform before attempts are made to free the platform or elevating assembly.

**10.11 Mobile Operation.** Before engaging in mobile operation the operator shall determine that the aerial device is specifically designed for mobile operation.

**10.11.1 Driver Precautions.** Before and during driving, the driver shall:

- (1) Avoid traveling on any surface that adversely affects vehicle stability.
- (2) Maintain a safe distance from obstacles and overhead lines.
- (3) Maintain communications between driver and operator.
- (4) Under all travel conditions, the driver shall limit travel speed in accordance with condition of the ground surface, congestion and slope.

**10.12 Training, Retraining and Familiarization of Operators.**

**10.12.1 General Training.** Only personnel who have received general instructions regarding the inspection, application and operation of aerial devices, including recognition and avoidance of hazards associated with their operation, shall operate an aerial device. Such items covered shall include, but not necessarily be limited to, the following issues and requirements:

- (1) The purpose and use of manuals.
- (2) That operating manuals are an integral part of the aerial device and must be properly stored on the vehicle when not in use.
- (3) A pre-start inspection.
- (4) Responsibilities associated with problems or malfunctions affecting the operation of the aerial device.
- (5) Prohibition of overriding safety devices except as approved by the manufacturer. (see 8.5.2).
- (6) That secondary operating systems shall not be used for purposes other than test or recovering the work platform.
- (7) Factors affecting stability.



- (8) The purpose of placards and decals.
- (9) Workplace inspection.
- (10) Applicable safety rules and regulations, such as Part 4, ANSI C2-2007, National Electrical Safety Code (applies to utility workers as defined in ANSI C2). The above standard is an example; other industries using aerial devices have safety rules pertinent to that industry.
- (11) Authorization to operate.
- (12) Securing the aerial device and mobile unit (MEWP) from unauthorized use.
- (13) Operator warnings and instructions.
- (14) Proper use of personal fall equipment. Fall systems criteria and practices are covered in 29 CFR 1926.502.
- (15) Actual operation of the aerial device. Under the direction of a qualified person, the trainee shall operate the aerial device for a sufficient period of time to demonstrate proficiency in the operation of all control functions of the aerial device and safe use at operating height and reach.
- (16) Stowing the aerial device for transport and precautions related to moving the mobile unit (MEWP).

**10.12.2 Retraining.** The operator shall be retrained, when so directed by the user, based on the following:

- (1) The user's observation and evaluation of the operator. This evaluation of the operator shall include evaluating the operator's proficiency of operating the aerial device in a safe manner.
- (2) After an accident or near miss while operating an aerial device.

**10.12.3 Familiarization.** When an operator is directed to operate an aerial device they are not familiar with, the operator, prior to operating, shall be instructed by a qualified person regarding the following items:

- (1) The location of the manuals.
- (2) The manufacturer's warnings and instructions.
- (3) The purpose and function of all controls.
- (4) Safety devices and operating characteristics specific to the aerial device.

The operator shall operate the aerial device for a sufficient period of time to achieve proficiency in the actual operation of the aerial device. Where authorized by the user, a qualified person may self-familiarize if the items above are completed.

**10.13 Electrical Hazard.** All applicable safety related work practices intended to protect personnel from electrical hazards shall be defined and explained to the operator by a qualified person. The operator shall maintain the appropriate Minimum Approach Distance (MAD) from energized conductors and apparatus commensurate with the operator's qualification. Aerial device or apparatus used to lift energized lines require use of an insulating device; that has been rated, tested and maintained for the appropriate line voltage to prevent energizing the boom tip. See Appendix F for information on the Minimum Approach Distance, handling energized apparatus and other precautions.

## 11. Responsibilities of Lessors or Lessees.

**11.1 General Responsibilities.** Each renter or lessor or lessee shall comply with the requirements of the applicable section or sections below.

**11.1.1 Lessor or Lessee as Dealer or Installer.** When a lessor or lessee uses the aerial device as a dealer or installer they shall have the same responsibilities as specified under Section 7 of this standard.

**11.1.2 Lessor or Lessee as Owner.** When a lessor or lessee uses the aerial device as an owner they shall have the same responsibilities as specified under Section 8 of this standard.

**11.1.3 Lessor or Lessee as User.** When a lessor or lessee uses the aerial device as a user they shall have the same responsibilities as specified under Section 9 of this standard.

**11.1.4 Lessor or Lessee as Operator.** When a lessor or lessee uses the aerial device as an operator they shall have the same responsibilities as specified under Section 10 of this standard.

**11.2 Ownership Responsibilities.** The lessor shall carry out the responsibilities of ownership specified in this standard which are not assigned to the lessee as the user.



## APPENDIX B

**11.3 Obligations.** Upon delivery each lessor of an aerial device shall provide the operators manual and the ANSI/SIA A92.2-2009 Manual of Responsibilities for dealers, owners, users, operators, lessors, lessees and brokers of Vehicle Mounted Elevating and Rotating Aerial Devices. These manuals shall be stored on the mobile unit (MEWP).

**11.3.1 Inspection and Test.** Prior to delivery, the lessor of an aerial device shall perform a frequent inspection as specified in Section 8.2.3 of this standard.

**11.3.2 Responsibilities.** Upon delivery, each lessor of an aerial device shall inform the lessee of their responsibilities in accordance with Section 8 as to inspection, testing and maintenance requirements; Section 9 as to user's responsibilities; and Section 10 as to operator's responsibilities.

**11.4 Training.** The lessor shall offer training or training materials that aid the lessee in the operation, inspection, testing and maintenance of the aerial device. This training shall be offered initially and subsequently on request.

**11.4.1 General training.** Only personnel who have received general instructions regarding the inspection, application and operation of aerial devices, including recognition and avoidance of hazards associated with their operation, shall operate an aerial device. Such items covered shall include, but not necessarily be limited to, the following issues and requirements:

- (1) The purpose and use of manuals.
- (2) That operating manuals are an integral part of the aerial device and must be properly stored on the vehicle when not in use.
- (3) A pre-start inspection.
- (4) Responsibilities associated with problems or malfunctions affecting the operation of the aerial device.
- (5) Prohibition of overriding safety devices except as approved by the manufacturer (see 8.5.2).
- (6) That secondary operating systems shall not be used for purposes other than test or recovering the work platform.
- (7) Factors affecting stability.
- (8) The purpose of placards and decals.
- (9) Workplace inspection.
- (10) Applicable safety rules and regulations, such as Part 4, ANSI C2-2007, National Electrical Safety Code (applies to utility workers as defined in ANSI C2). The above standard is an example; other industries using Aerial Devices have safety rules pertinent to that industry.
- (11) Authorization to operate.
- (12) Securing the aerial device and mobile unit (MEWP) from unauthorized use.
- (13) Operator warnings and instructions.
- (14) Proper use of personal fall equipment. Fall systems criteria and practices are covered in 29 CFR 1926.502.
- (15) Actual operation of the aerial device. Under the direction of a qualified person, the trainee shall operate the aerial device for a sufficient period of time to demonstrate proficiency in the operation of all control functions of the aerial device and safe at operating height and reach.
- (16) Stowing the aerial device for transport and precautions related to moving the mobile unit (MEWP).

**11.4.2 Retraining.** The operator shall be retrained when so directed by the user, based on the following:

- (1) The user's observation and evaluation of the operator. This evaluation of the operator shall include evaluating the operator's proficiency of operating the aerial device in a safe manner.
- (2) After an accident or near miss while operating an aerial device.

**11.4.3 Familiarization.** When an operator is directed to operate an aerial device they are not familiar with, the operator, prior to operating, shall be instructed by a qualified person regarding the following items:

- (1) The location of the manuals.
- (2) The manufacturer's warnings and instructions.
- (3) The purpose and function of all controls.
- (4) Safety devices and operating characteristics specific to the aerial device.



The operator shall operate the aerial device for a sufficient period of time to achieve proficiency in the actual operation of the aerial device. Where authorized by the user, a qualified person may self-familiarize if the items above are completed.

**11.5 Communications.** In the event the manufacturer or installer provides the lessor manuals, bulletins, or other materials for the information of the user of an aerial device, the lessor shall pass them on to the user without delay.

**11.6 Use of Brokers.** If Brokers are employed in leasing, the responsibility of lessors and lessees as specified in this Section continue even though a Broker may be involved in the transaction.

## **12. RESPONSIBILITIES OF BROKERS.**

**12.1 Broker Involved In a Sale.** A broker involved in a sale shall:

- (1) Assure that the entity actually transferring ownership knows the proper location and identification of proper of the purchasing entity.
- (2) Confirm that operations and maintenance manuals are provided to the new owner.
- (3) Confirm that all parties are aware of their responsibilities under Section 8.7 of this standard.

**12.2 Broker Involved In a Lease.** A broker involved in a lease shall:

- (1) Assure that the entity actually transferring possession know the proper location and identification of the proper personnel of the lessee or user of the aerial device.
- (2) Confirm that the operators' manual, maintenance manual, and Manual of Responsibilities are provided to the lessee.
- (3) Confirm that all parties are aware of their responsibilities under Section 11.4 of this standard.



## SURVEY OF JOB SITE

Appendix (This Appendix is not part of American National Standard A92.2-2009 - but is included for information only.)

Construction and electrical workers are subject to certain hazards that cannot be eliminated by mechanical means and must be controlled by care, common sense and intelligence. Terex South Dakota, Inc. realizes the importance of safety and strongly recommends that prior to commencing any operation, the employer make a survey of the conditions of the site to determine the hazards and the kind and number of safeguards that the employer will install.

The survey should include, but not be limited to, the following:

- (1) Safe access and movement
  - (a) Work areas
  - (b) Walkways, runways and passageways
  - (c) Ladders, stairways and elevators
  - (d) for floor and roof openings
  - (e) Illumination
- (2) Vehicles
  - (a) Roads
  - (1) Turn space
  - (2) Parking area
  - (3) Mud areas
    - (b) Materials storage areas and dump areas
    - (c) Signs and signals to route vehicles on the job
    - (d) Maintenance and repairs of vehicles
  - (3) Utilities and service
    - (a) Location of temporary buildings
    - (b) Location and identification of high-voltage lines (identify by signs; move, de-energize or erect barrier to prevent contact)
    - (c) Location of sanitary facilities and drinking water
  - (4) Scheduling work for safety
    - (a) Providing hard hats, life belts, goggles, work vests and the like on the job
    - (b) Establishing liaison among contractors to prevent congestion among trades
    - (c) Providing temporary flooring, safety nets and scaffolding where required
  - (5) Work Procedures
    - (a) Space
    - (b) Equipment such as cranes, hoists, elevators and trucks
    - (c) Rigging procedures
    - (d) Personal protective equipment
  - (6) Tools and equipment
    - (a) Repair, maintenance and care
    - (b) Inspection
    - (c) Supplies of tools for each job
  - (7) Workers and foremen
    - (a) Job assignment
    - (b) Training and supervision





- (c) Number of workers
- (d) Plans for maintaining interest in safety:
  - (1) Safety bulletins, record charts and posters
  - (2) Recognition for groups or individuals
  - (3) Investigation and reporting on reportable accidents
  - (4) Knowledge of safety orders
  - (5) Safety meetings
  - (6) Specific safety instructions for new employees
- (e) Establishment of provisions to take immediate action to correct unsafe conditions or acts
- (f) First aid and medical treatment of injuries