

REELSTRONG[®]

UTILITY FLEET

Reel, Pole and Gas Trailers using ACME-Clamp™, Safelock™, and Securelock™ Technologies

SL20K-T SERIES with SAFELOCK™ TECHNOLOGY

OPERATOR'S MANUAL



BUILT FOR SAFETY. BUILT FOR SPEED. *BUILT TO LAST.*

WARNING

This User's Manual contains safety information and instructions for your trailer.
. **YOU** must read this manual before loading or towing your trailer.
YOU must follow all safety precautions and instructions.

SL20K-T SERIES TRAILER SPECIFICATIONS

Trailer Capacities:

Estimated Unladen Trailer Weight: 3,600 lbs

- Actual trailer weight will vary with options & finishes chosen.

Axle Configuration: Tandem, Sprung, Electric Brakes (air brakes optional)

- (2) 10K Sprung Axle: 22,100 GWVR @ 15% Tongue Weight

Wheels & Tires:

- 10k Axle: (4) 215/75R17.5 LH

Reel Drive Bar Capacity:

- Standard Maximum Reel Diameter: 96" (custom sizes possible)
- Standard Maximum Reel Width: 54" (60" w/ 102" wide trailer)
- Standard Reel Drive Bar: 1.875"O.D. x .5"Wall w/ Centering Collars

Overall Widths Available:

- 96" & 102"

Length:

- Approximately-197.5"', actual length (hitch to outrigger)

Standard Added Value Features:

- Safelock™ Technology - provides industry leading safety, ease of use, low maintenance, and durability
 - Safer because there is nothing to lose and easy to use. No pins, cotters or lanyards to brake, one hand to open and close
 - Faster loading/unloading of reel. Just pull the Safelock™ handle out until it catches load/unload your reel then tap the handle and the mechanism will spring shut.

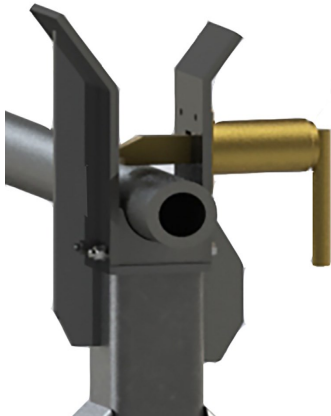

**Safelock™
Technology**

All Specifications / Designs are subject to change without notice

All unladen trailer weights are estimates and may vary depending on options& materials chosen

All GVWR's & reel capacity are de-ratable to your needs.

SL20K-T SERIES TRAILER SPECIFICATIONS

Standard Features:

- Frame 1/4" Thick Wall Heavy Duty Tubular Steel construction, size based on payload options chosen.
- Hitch: 2.5" - 15 Ton Pintle, 6 Position Adjustable
- (2) 3/8" Zinc Plate Grade 70 Alloy Chains with Hook
- (1) A-Frame 12K Static Jack with Spring Return Side Wind Drop Leg
- (4) Stabilizer Jacks (1 at each corner of bed)
- Oil Bath Hubs (Greaseable Optional)
- Electric Brakes - air brakes option available
- Wheel Chock Holders
- Anti-lock Brakes (ABS)

Wiring:

- DOT/ICC Approved LED Lights and Conspicuity Reflective Tape
- Internal Cat Track Protects Wiring (air brakes if applicable)
- Sealed Beam, Rubber Mounted Stop, Turn, Tail, and Marker Lights.
- Wiring Harness Terminated in Junction Boxes with Heat Shrink Connectors (soldering optional)
- Breakaway Kit with Absorbed Glass Mat (AGM) Battery

Paint:

- I.M.P.A.C.T. Intense Metal pH Acid Cleaning Technology
- Hydrofluoric, Sulfuric, Phosphoric ACID BLEND CLEANING PREP.
- Seams Caulked I.M.P.A.C.T. Intense Metal pH Acid Cleaning Technology
- Rust Preventative 2-Part Epoxy Primer
- Standard Colors Red, Black, White & CAT Yellow

Available Options:

- **Galvanizing Option: 3-Step Hot Dip Galvanizing**
(includes 10 year Structural Warranty)

All Specifications / Designs are subject to change without notice

All unladen trailer weights are estimates and may vary depending on options & materials chosen

All GVWR's & reel capacity are de-ratable to your needs.

SL20K-T SERIES TRAILER SPECIFICATIONS

Available Options (cont'd):

- 20" Rotor Hydraulic Controlled Tension Brake System
- 3" Lunette Eye Pintle
- 1/2" Safety Chains Available
- Wiring Connections Soldered and Sealed w/ Heat Shrink Tubing
- Wheel Chocks: Rubber or All Weather Galvanized Grip Strut
- Solar Charged Breakaway Kit
- Plug & Play Wiring System
- 13 HP Honda Driven Hydraulic Power Pack
- Side Access Tool Box

Reel Options:

- 16" Ventilated Tru-Stop Self Cooling Tension Brake 4,200 ft/lbs
- Hydraulic Power Winder (pay-in/pay-out) 3,350 ft/lbs Torque Std.
- Capstan Adapter

All Specifications / Designs are subject to change without notice

All unladen trailer weights are estimates and may vary depending on options & materials chosen

All GVWR's & reel capacity are de-ratable to your needs.

AT REELSTRONG SAFETY IS #1

YOUR PINLESS TRAILER IS ENGINEERED WITH "SAFETY 1ST" IN MIND

However, the operator must read all reel trailer safety information in this manual and on the trailer's warning, caution and informational stickers carefully and fully understand all applications and instructions in this manual before towing the trailer.

PRE-TRANSPORT INSTRUCTIONS

- **MAKE SURE TRAILER IS PROPERLY CONNECTED TO TOW VEHICLE BEFORE LOADING OR UNLOADING REELS. (SEE OPERATING INSTRUCTIONS FOR REEL LOADING/UNLOADING PROCEDURE)**
- **MAKE SURE THE TRAILER AND THE TOW VEHICLE WHEELS ARE PROPERLY CHOCKED AND STABILIZING JACKS ARE LOWERED TO GRADE PRIOR TO LOADING, UNLOADING REEL OR DISTRIBUTING CABLE.**
- MAKE SURE REEL IS CENTERED ON THE REEL BAR AND LOCK COLLARS SECURED BEFORE LOADING & TRANSPORT.
- MAKE SURE BOTH SAFELOCK LATCHES OF EACH REEL BAR POSITION ARE DEPRESSED AND IN THE LOCKED POSITION PRIOR TO LOADING OR TRANSPORT. SEE ILLUSTRATION ON FOLLOWING PAGE.
- MAKE SURE ALL NUTS, LUG NUTS, BOLTS, AND MECHANICAL DEVICES ARE TIGHT, SECURE, AND IN PROPER WORKING CONDITION.
- CONFIRM TIRES PROPERLY INFLATED (see manual for inflation instructions)
- VERIFY THE GVW WEIGHT RATING WILL NOT BE EXCEEDED PRIOR TO LOADING TRAILER. (**18,000 LBS MAX PAYLOAD**)
- CONFIRM FRONT & REAR JACKS ARE RAISED TO THE HIGHEST POSITION PRIOR TO TOWING TRAILER.
- CONFIRM ALL HITCH MECHANISMS AND SAFETY CHAINS ARE PROPERLY ATTACHED AND SECURED.
- CONFIRM ALL ELECTRICAL CONNECTIONS & LIGHTS WORKING PROPERLY.
- CONFIRM BRAKES ARE WORKING PROPERLY BEFORE APPROACHING AN INCLINE, ENTERING TRAFFIC &/OR PUBLIC ROADS.

RECOMENDATIONS & MAINTENANCE

- **ON TRAILERS WITH ON BOARD HYDRAULIC POWER PACK OPTION CLEAR HYDRAULIC FLUID RESERVOIR AND CHANGE FLUID EVERY FALL SEASON**

SAFETY ALERT SYMBOLS AND SIGNAL WORDS

An Owner's Manual that provides general trailer information cannot cover all specific details necessary for the proper combination of every trailer, tow vehicle and hitch. Therefore, you must read, understand and follow the instructions from the tow vehicle and trailer hitch manufacturers, as well as the instructions in this manual.

Our trailers are built with components produced by various manufacturers. Some of these items have separate instruction manuals. Where this manual indicates that you should read another manual, and you do not have that manual or know the manufacturer of that particular part, call Reelstrong at 484-889-8048 to find out how to get a free copy.

The safety information in this manual is denoted by the safety alert symbol: 

Loading/Unloading Procedure:

Loading:

Step 1: Ensure tow vehicle & trailer are on a level grade and trailer is connected securely to tow vehicle per hitch manufacturer's instructions. Connect safety chains crossing them per DOT regulations and securely attach breakaway switch / air brake glad hands to vehicle in such away as to ensure activation if trailer becomes unhitched for any reason. See illustration below as an example of good general practices for hitch connection.

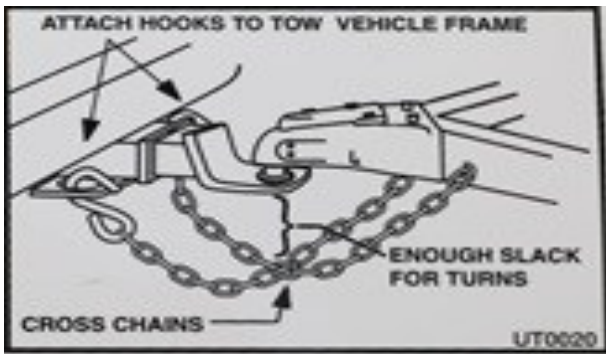

Step 2: Connect trailer electrical connections and ensure all marker lights, brake lights and turn signals are functioning properly.

Step 3: Chock the wheels of the trailer and ensure the tow vehicle is prevented from moving with wheel chocks or other method that will provide safety and stability to the tow vehicle.

Step 4: If your trailer is equipped with front &/or rear stabilizing jacks lower them to grade.

Step 5: Pull the Safelock™ latches located on each end of the reel bar all the way out until the latch catches and is held in the open position. See illustration below.



Step 6: Stabilize the reel on level ground using wheel chocks to prevent reel from rolling. Install the reel bar assuring the drive bar drive pins are fully engaged with the reel and the drive bar is flush against the reel. Secure the reel bar across the reel with the centering collar by tightening the set screws and jam nuts .

Step 7: Using the lifting lug locations secure the reel bar properly with rigging suitable for the weight of the load and lift the reel bar into the saddle.

Step 8: Close the Safelock™ latches located on each end of the reel bar. See illustration below.

Step 9: Close the Safelock™ latches located on each end of the reel bar. See illustration below.



Step 10: Remove the wheel chocks and place in a secure location such as the wheel chock holders typically provided or a tool box. This is good time to conduct a safety walk around and a second check of the hitch, lights and Safelock™ systems on your trailer.

Step 11: Check Brake function before towing trailer.

Unloading Procedure:

Step 1: Make sure vehicle and trailer are on level ground and stabilized from movement with wheel chocks etc.

Step 2: Open Safelock™ Latches & rig reelbar appropriately for estimated weight

Step 3: Lift and place reel on level ground using wheel chocks to stabilize against roll away.

Safety Placards & Decals

Shown below are some of the safety decals or placards used on the trailers. Failure to heed these warnings could result in road hazard, personal injury, or death. You must order replacements if any of these stickers are torn or have been removed or become illegible for any reason. Contact Reelstrong Utility Fleet at 484-889-8048.



Safety Decal located on Reel Bar Seat



Safety Decal located in A-frame of trailer



Safety Decal located in A-frame of trailer

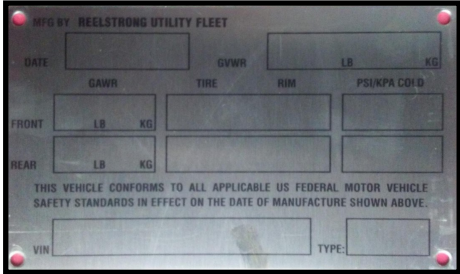

Vin Plate Located in A-frame area of trailer

Starting from the most dangerous at the top, the level of risk is indicated by the following signals:

^DANGER

DANGER—Immediate hazards which WILL result in severe personal injury or death if the warning is ignored.

^WARNING

WARNING—Hazards or unsafe practices which COULD result in severe personal injury or death if the warning is ignored.

^CAUTION

CAUTION—Hazards or unsafe practices which could result in minor or moderate injury if the warning is ignored.

^NOTICE

NOTICE—Practices that could result in damage to the trailer or other property.

HAZARDS

Loss of control of the trailer or trailer/tow vehicle combination can result in death or serious injury. The most common causes for loss of control of the trailer are:

- Improper sizing of the trailer for the tow vehicle, or vice versa.
- Excessive Speed: Driving too fast for the conditions.
- Failure to adjust driving behavior when towing a trailer.
- Overloading and/or improper weight distribution.
- Improper or mis-coupling of the trailer to the hitch.
- Improper braking and steering under sway conditions.
- Not maintaining proper tire pressure.
- Not keeping lug nuts tight

MAINTENANCE OF MECHANICAL PARTS

Your reel trailer is only safe if properly maintained regularly. Always check to make sure all mechanical parts are in proper working condition before transporting reel trailer. Make sure all nuts and bolts are tight and weldments in satisfactory condition. Illustrated below are primary parts to maintain and make certain are in good working condition at all times.

IMPROPER SIZING OF THE TRAILER TO THE TOW VEHICLE

Trailers that weigh too much for the towing vehicle can cause stability problems, which can lead to death or serious injury. Furthermore, the additional strain put on the engine and drivetrain may lead to serious tow vehicle maintenance problems. For these reasons the maximum towing capacity of your towing vehicle should not be exceeded. The towing capacity of your tow vehicle, in terms of maximum Gross Trailer Weight (GTW) and maximum Gross Combined Weight Rating (GCWR) can be found in the tow vehicles Owner's Manual.

^DANGER

Use of tow vehicle with a towing capacity less than the Gross Vehicle Weight Rating of the trailer can result in loss of control, and may lead to death or serious injury.
Be sure your hitch and tow vehicle are rated for the Gross Vehicle Weight Rating of your trailer.

DRIVING TOO FAST

With ideal road conditions, the maximum recommended speed for safely towing a trailer is 60 mph. If you drive too fast, the trailer is more likely to sway, thus increasing the possibility for loss of control. Also your tires may overheat, thus increasing the possibility of a blowout.

^WARNING

Driving too fast for conditions can result in loss of control and cause death or serious injury. Decrease your speed when going downhill or as road, weather and lighting conditions deteriorate.

FAILURE TO ADJUST DRIVING BEHAVIOR WHEN TOWING A TRAILER

When towing a trailer, you will have decreased acceleration, increased stopping distance, and increased turning radius (which means you must make wider turns to keep from hitting curbs, vehicles, and anything else that is on the inside corner). Furthermore the trailer will change the handling characteristics of your towing vehicle, making it more sensitive to steering inputs and more likely to be pushed around in windy conditions or when being passed by large vehicles. In addition, you will need a longer distance to pass, due to slower acceleration and increased length. With these caveats in mind:

- Be alert for slippery conditions. You are more likely to be affected by slippery road surfaces when driving a tow vehicle with a trailer, than driving a tow vehicle without a trailer.
- Anticipate the trailer "swaying." Swaying can be caused by excessive steering, wind gusts, road-way edges, or by the trailer reaction to the pressure wave created by passing trucks and busses.
- When encountering trailer sway take your foot off the gas, and steer as little as possible in order to stay on the road. Use small "trim like" steering adjustments. Do not attempt to steer out of the sway; you'll only make it worse. Also do not apply the tow vehicle brakes to correct trailer swaying. On the other hand, application of the trailer brakes alone will tend to straighten out the combination, especially when going downhill.
- Check rearview mirrors frequently to observe the trailer & traffic.
- Use lower gear when driving down steep or long grades. Use the engine and transmission as a brake. Do not ride the brakes, as they can over heat and become ineffective.
- Be aware of your trailer height, especially when approaching bridges, roofed areas and around trees.

TRAILER NOT PROPERLY COUPLED TO THE HITCH

It is critical that the trailer be securely coupled to the hitch ball or pintle hitch, and that the safety chains and emergency break-away brake cable are correctly attached. Uncoupling may result in death or serious injury to you and to others.

^WARNING

Proper selection and condition of the coupler and hitch are essential to safely towing your trailer. A loss of coupling may result in death or serious injury.

- Be sure the maximum load rating of the hitch on the tow vehicle is equal to or greater than the maximum load rating of the coupler on the trailer.
 - Be sure the hitch ball or pintle hitch size matches the coupler size.
- Observe the hitch for wear, corrosion and cracks before coupling. Replace worn, corroded or cracked hitch components before coupling the trailer to the tow vehicle.
- Be sure the hitch components are tight before coupling the trailer to the tow vehicle.

^WARNING

An improperly coupled trailer can result in death or serious injury.

DO NOT MOVE THE TRAILER UNTIL:

- The coupler is secured and locked to hitch ball;
- The safety chains are secured to the tow vehicle;
 - The trailer jack(s) are fully retracted.

DO NOT TOW THE TRAILER ON THE ROAD UNTIL:

- Tires and wheels are checked;
- The trailer brakes are checked;
- The breakaway switch is connected to the tow vehicle
 - The load is secured to the trailer; and
- The trailer lights are connected and checked.

PROPER USE OF SAFETY CHAINS

If your trailer comes loose from the hitch for any reason, Reelstrong has provided safety chains so that control of the trailer can still be maintained.

^WARNING

Improper rigging of the safety chains can result in loss of control of the trailer and tow vehicle, leading to death or serious injury, if the trailer uncouples from the tow vehicle.

- Fasten chains to frame of tow vehicle. Do not fasten chains to any part of the hitch unless the hitch has holes or loops specifically for that purpose.
- Cross chains underneath hitch and coupler with enough slack to permit turning and to hold tongue up, if the trailer comes loose.

PROPER CONNECTION OF BREAKAWAY BRAKE

If equipped with brakes your trailer will be equipped with a breakaway brake system that can apply the brakes on your trailer if your trailer comes loose from the hitch ball for any reason. You will have a separate set of instructions for the breakaway brake if your trailer is so equipped. The breakaway brake system, including battery, must be in good condition and properly rigged to be effective.

^WARNING

An ineffective or inoperative breakaway brake system can result in a runaway trailer, leading to death or serious injury, if the coupler or hitch fails. The breakaway cable must be connected to the tow vehicle; and NOT to any part of the hitch. Before towing the trailer, test the function of the breakaway brake system. If the breakaway brake system is not working, do not tow the trailer; have it serviced or repaired.

MATCHING TRAILER AND HITCH

^DANGER

Use of a hitch with a load rating less than the load rating of the trailer can result in loss of control and may lead to death or serious injury.

WORN TIRES, LOOSE WHEELS AND LUG NUTS

Just as with your tow vehicle the trailer tires and wheels are important safety items. Therefore, it is essential to inspect the trailer tires before each tow.

If a tire has a bald spot, bulge, cut, cracks, or is showing any cords, replace the tire before towing. If a tire has uneven tread wear, take the trailer to a dealer service center for diagnosis. Uneven tread wear can be caused by tire imbalance, axle misalignment or incorrect inflation.

Tires with too little tread will not provide adequate frictional forces on wet roadways and can result in loss of control, leading to death or serious injury.

Improper tire pressure causes increased tire wear and may reduce trailer stability, which can result in a tire blowout or possible loss of control. Therefore, before each tow you must also check the tire pressure. Remember, the proper tire pressure is listed on the Certification / VIN label, normally mounted on the front Driver's side of the trailer, and should be checked when tires are cold. Allow 3 hours cool-down after driving as much as 1 mile at 40 mph before checking tire pressure.

^WARNING

Improper tire pressure can result in a blowout and loss of control, which can lead to death or serious injury. Be sure tires are inflated to pressure indicated on the Certification / VIN label before towing trailer.

LUG NUT TIGHTNESS

The tightness of the lug nuts is very important in keeping the wheels properly seated to the hub!

Before each tow, check to make sure they are tight.

^WARNING

Metal creep between the wheel rim and hub may cause lug nuts to loosen and could result in a wheel coming off, leading to death or serious injury. Tighten lug nuts before each tow.

The proper tightness (torque) for lug nuts is listed in Section 3.1.1 Use a torque wrench to tighten the lug nuts, use the criss-cross star pattern. If you do not have a torque wrench, use a lug wrench (from your tow vehicle) and tighten the nuts as

much as you can. At the first opportunity, have a service garage or trailer dealer tighten the lug nuts to the proper torque.

Lug nuts are also prone to loosen after first being assembled. When driving a new trailer (or after wheels have been remounted), check to make sure they are tight after the first 10, 25 and 50 miles of driving and before each tow thereafter.

Failure to perform this check can result in a wheel separating from the trailer and a crash, leading to death or serious injury.

^WARNING

Lug nuts are prone to loosen after initial installation, which can lead to death or serious injury. Check lug nuts for tightness on a new trailer or when wheel(s) have been remounted after the first 10, 25 and 50 miles of driving.

^WARNING

Improper lug nut torque can cause a wheel separating from the trailer, leading to death or serious injury. Be sure lug nuts are tight before each tow.

IMPROPER LOADING

The total weight of the load you put in or on the trailer, plus the empty weight of the trailer itself, must not exceed the trailer's Gross Vehicle Weight Rating. If you do not know the empty weight of the trailer plus the cargo weight, you must weigh the loaded trailer at a commercial scale. Your trailer is equipped with a Tire & Loading Information Placard, mounted next to the Certification / VIN label, the cargo capacity weight stated on that placard is only a close estimate. The GVWR and GAWR's are listed on the Certification / VIN label mounted on the front left side of the trailer.

^WARNING

An overloaded trailer can result in loss of control of the trailer, leading to death or serious injury. Do not exceed the trailer Gross Vehicle Weight Rating (GVWR) or an axle Gross Axle Weight Rating (GAWR). Do not load a trailer so that the weight on any tire exceeds its rating.

UNSAFE LOAD DISTRIBUTION

Improper load distribution can lead to poor trailer sway stability or poor tow vehicle handling. Poor trailer sway stability results from tongue weights that are too low, and poor tow vehicle stability results from tongue weights that are too high. Refer to Chapter heading "Loading the Trailer" for more information.

In the table below, the second column shows the rule of thumb percentage of total weight of the trailer plus its cargo (Gross Trailer Weight, or "GTW") that should appear on the tongue of the trailer.

After loading, be sure to check that none of the axles are overloaded.

Tongue Weight as a Percentage of Loaded Trailer Weight	
Type of Hitch	Percentage
Pintle Hitch	10-15%

^WARNING

Improper tongue weight (load distribution) can result in loss of control of the trailer, leading to death or serious injury. Make certain that tongue weight is within the allowable range.

Be sure to: Center distribute the load properly.

SHIFTING REEL

You must center the reel from side-to-side so that it does not shift while the trailer is being towed. Your reel trailer is only safe as long as all local and state speed limits are obeyed and the reel is centered with the centering collars locked in place. Uneven left / right load distribution can cause tire, wheel, axle or structural malfunction and void your manufacturer's warranty.

^WARNING

Shifting reel can result in loss of control of the trailer, and can lead to death or serious injury. Make sure to tighten spool collars so that reel is centered on trailer before transport.

INAPPROPRIATE CARGO

Your trailer is only designed to transport cable reels and accessories. A cable reel trailer must not be used to carry items such as people, containers of hazardous substances and containers of flammable substances.

^WARNING

Do not transport people or any other items that are not intended to be transported by the trailer. The transport of people puts their lives at risk and may be illegal.

^WARNING

Do not transport flammable, explosive, poisonous or other dangerous materials in or on your trailer.

Exceptions:

- Battery stored on trailer used to power electric hydraulic unit.

INOPERABLE BRAKES, LIGHTS OR MIRRORS

Be sure that the electric brakes and all of the lights on your trailer are functioning properly before towing your trailer. Electric brakes and lights on a trailer are controlled via a connection to the tow vehicle, generally a multi-pin electrical connector. Check the trailer tail lights by turning on your tow vehicle headlights. Check the trailer brake lights by having someone step on the tow vehicle brake pedal while you look at trailer lights. Do the same thing to check the turn signal lights.

Your tow vehicle must have an electric brake controller that sends power to the trailer brakes. Before towing the trailer on the road, you must operate the brake controller while trying to pull the trailer in order to confirm that the electric brakes operate. While towing the trailer at less than 5 mph, manually operate the electric brake controller in the tow vehicle cab. You should feel the operation of the trailer brakes.

^WARNING

Improper electrical connection between the tow vehicle and the trailer will result in inoperable lights and electric brakes, and can lead to collision.

Before each tow:

- Check that the taillights, brake lights and turn signals work.
- Check that the electric brakes work by operating the brake controller inside the tow vehicle.

Standard mirrors usually do not provide adequate visibility for viewing traffic to the sides and rear a towed trailer. You must provide mirrors that allow you to safely observe approaching traffic.

HAZARDS FROM MODIFYING YOUR TRAILER

Essential safety items can be damaged by altering your trailer. Even simply adding a small weldment can damage an electrical circuit, or other feature of the trailer.

Before making any alteration to your trailer, contact your dealer or Reelstrong and describe the alteration you are contemplating. Alteration of the trailer structure or modification of mechanical, electrical, or other systems on your trailer must be performed only by qualified technicians who are familiar with the systems installed on your trailer. Any alteration to your Reelstrong trailer without written approval from Reelstrong INTL will void the warranty.

SAFETY WARNING LABELS ON YOUR TRAILER

The following is an assemblage of our trailer warning and caution stickers that must be present on the trailer in order for the trailer operator to understand the safe operation of the reel trailer. If any of these stickers is unreadable, missing or damaged call your local Reelstrong dealer or Reelstrong at 484-889-8048 for a free replacement label.

^WARNING

To protect you and others against death or serious injury, all of the labels shown above must be on the trailer and be legible.

If any of these labels are missing or cannot be read, call Reelstrong at 484.889.8048 for free replacement labels.

GENERAL TRAILER TOWING GUIDE

Driving a vehicle with a trailer in tow is vastly different from driving the same vehicle without a trailer in tow. Acceleration, maneuverability and braking are all diminished with a trailer in tow. It takes longer to get up to speed; you need more room to turn and pass, and more distance to stop when towing a trailer. You will need to spend time adjusting to the different feel and maneuverability of the tow vehicle with a loaded trailer. Because of the significant differences in all aspects of maneuverability when towing a trailer, the hazards and risks of injury are also much greater than when driving without a trailer. You are responsible for keeping your vehicle and trailer in control, and for all the damage that is caused if you lose control of your vehicle and trailer.

As you did when learning to drive an automobile, find an open area with little or no traffic for your first practice traileering. Of course, before you start towing the trailer, you must follow all of the instructions for inspection, testing, loading and coupling. Also, before you start towing, adjust the mirrors so you can see the trailer as well as the area to the rear of it.

Drive slowly at first, 5 mph or so, and turn the wheel to get the feel of how the tow vehicle and trailer combination responds. Next, make some right and left hand turns. Watch in your side mirrors to see how the trailer follows the tow vehicle. Turning with a trailer attached requires more room.

Stop the rig a few times from speeds no greater than 10 mph. If your trailer is equipped with brakes, try using different combinations of trailer/electric brake and tow vehicle brake. Note the effect that the trailer brakes have when they are the only brakes used. When properly adjusted, the trailer brakes will come on just before the tow vehicle brakes.

It will take practice to learn how to back up a tow vehicle with a reel trailer attached. Short length trailers with single axles are difficult to back up without jack-knifing. Take it slow. Before backing up, get out of the tow vehicle and look behind the trailer to make sure that there are no obstacles. Some drivers place their hands at the bottom of the steering wheel, and while the tow vehicle is in reverse, "think" of the hands as being on the top of the wheel. When the hands move to the right (counter-clockwise, as you would do to turn the tow vehicle to the left when moving forward), the rear of the trailer moves to the right. Conversely, rotating the steering wheel clockwise with your hands at the bottom of the wheel will move the rear of the trailer to the left, while backing up. If you are towing a bumper hitch rig, be careful not to allow the trailer to turn too much, because it will hit the rear of the tow vehicle. To straighten the rig, either pull forward, or turn the steering wheel in the opposite direction.

REPORTING SAFETY DEFECTS

If you believe that your vehicle has a defect that could cause a crash or could cause injury or death, you should immediately inform the National Highway Traffic Safety Administration (NHTSA) in addition to notifying Reelstrong.

If NHTSA receives similar complaints, it may open an investigation, and if it finds that a safety defect exists in a group of vehicles, it may order a recall and remedy campaign. However, NHTSA cannot become involved in individual problems between you, your dealer and Reelstrong.

To contact NHTSA, you may either call the Vehicle Safety Hotline toll-free at 1-888-327-4236 (TTY: 1-800-424-9153), go to <http://www.safercar.gov>; or write to: Administrator, NHTSA, 400 Seventh Street, SW., Washington, DC 20590. You can also obtain other information about motor vehicle safety from <http://www.safercar.gov>.

Call Reelstrong at 484-889-8048 should you have any concerns regarding the latter information.

ADDITIONAL SAFE TRAILER TOWING GUIDELINES

- Before towing, check coupling, safety chain, safety brake, tires, wheels and lights.
- Check the lug nuts or bolts for tightness.
- Check coupler tightness after towing 50 miles.
- Adjust the brake controller to engage the trailer brakes before the tow vehicle brakes. Follow the instructions given with the brake controller manufacturer's literature.
- Use your mirrors to verify that you have room to change lanes or pull into traffic.
- Use your turn signals well in advance.
- Allow plenty of stopping space for your trailer and tow vehicle.
- Do not drive so fast that the trailer begins to sway due to speed. Generally never drive faster than 60 m.p.h.
- Allow plenty of room for passing. A rule of thumb is that the passing distance with a trailer is 4 times the passing distance without a trailer.
- Shift your automatic transmission into a lower gear for city driving.
- Use lower gears for climbing and descending grades.
- Do not ride the brakes while descending grades, they may get so hot that they stop working. Then you will potentially have a runaway tow vehicle and trailer.
- To conserve fuel, don't use full throttle to climb a hill. Instead, build speed on the approach.
- Slow down for bumps in the road. Take your foot off the brake when crossing the bump.

- Do not brake while in a curve unless absolutely necessary. Instead, slow down before you enter the curve.
- Do not apply the tow vehicle brakes to correct extreme trailer swaying. Instead, lightly apply the trailer brakes with the hand controller.
- Make regular stops, about once each hour.

Confirm that:

- The coupler is secure to the hitch and is locked,
- Electrical connectors are made,
- There is appropriate slack in the safety chains,
- There is appropriate slack in the breakaway switch pull-pin cable,
- The tires are not visibly low on pressure, and
- The cargo is secure and in good condition.

TIRE SAFETY INFORMATION

This portion of the User's Manual contains tire safety information as required by 49 CFR 575.6.

Section 2.1 contains "Steps for Determining Correct Load Limit - Trailer".

Section 2.2 contains "Steps for Determining Correct Load Limit - Tow Vehicle".

Section 2.3 contains a Glossary of Tire Terminology, including "cold inflation pressure", "maximum inflation pressure", "recommended inflation pressure", and other non-technical terms.

Section 2.4 contains information from the NHTSA brochure entitled "Tire Safety - Everything Rides On It".

This brochure describes the following items;

- Tire labeling, including a description and explanation of each marking on the tires, and information about the DOT Tire Identification Number (TIN).

- Recommended tire inflation pressure, including a description and explanation of:

- Cold inflation pressure.
- Vehicle Placard and location on the vehicle.
- Adverse safety consequences of under inflation (including tire failure).
- Measuring and adjusting air pressure for proper inflation.
 - Tire Care, including maintenance and safety practices.
 - Vehicle load limits, including a description and explanation of the following items:

A. Locating and understanding the load limit information, total load capacity, and cargo capacity.

B. Calculating total and cargo capacities with varying seating configurations including quantitative examples showing / illustrating how the vehicles cargo and luggage capacity decreases

as combined number and size of occupants' increases. This item is also discussed in Section 3.

C. Determining compatibility of tire and vehicle load capabilities.

D. Adverse safety consequences of overloading on handling and stopping on tires.

Actual tire size and weight limits are different than shown below.

TIRE AND LOADING INFORMATION			
The weight of cargo should never exceed XXX kg. or XXX lbs.			
TIRE	SIZE	COLD TIRE PRESSURE	SEE OWNER'S MANUAL FOR ADDITIONAL INFORMATION
FRONT	20.5x8.0-10(E)	621KPA, 90PSI	
REAR			
SPARE	NONE		

STEPS FOR DETERMINING CORRECT LOAD LIMIT—TRAILER

TRAILERS 10,000 POUNDS GVWR OR LESS

1. Locate the statement, "The weight of cargo should never exceed XXX kg or XXX lbs.," on your vehicle's placard. See figure 1-1.

2. This figure equals the available amount of reel weight capacity which is 5,000 lbs.

3. Determine the combined weight of reel being loaded on the vehicle. That weight may not safely exceed the available cargo capacity.

The trailer's placard refers to the Tire Information Placard attached adjacent to or near the trailer's VIN (Certification) label at the left front of the trailer.

GLOSSARY OF TIRE TERMINOLOGY

Accessory Weight

The combined weight (in excess of those standard items which may be replaced) of automatic transmission, power steering, power brakes, power windows, power seats, radio and heater, to the extent that these items are available as factory-installed equipment (whether installed or not).

Bead

The part of the tire that is made of steel wires, wrapped or reinforced by ply cords and that is shaped to fit the rim.

Bead Separation

This is the breakdown of the bond between components in the bead.

Bias Ply Tire

A pneumatic tire in which the ply cords that extend to the beads are laid at alternate angles substantially less than 90 degrees to the centerline of the tread.

Carcass

The tire structure, except tread and sidewall rubber which, when inflated, bears the load.

Chunking

The breaking away of pieces of the tread or sidewall.

Cold Inflation Pressure

The pressure in the tire before you drive

Cord

The strands forming the plies in the tire.

Cord Separation

The parting of cords from adjacent rubber compounds.

Cracking

Any parting within the tread, sidewall, or inner liner of the tire extending to cord material.

CT

A pneumatic tire with an inverted flange tire and rim system in which the rim is designed with rim flanges pointed radially inward and the tire is designed to fit on the underside of the rim in a manner that encloses the rim flanges inside the air cavity of the tire.

Curb Weight

The weight of a motor vehicle with standard equipment including the maximum capacity of fuel, oil, and coolant, and, if so equipped, air conditioning and additional weight optional engine.

Extra Load Tire

A tire designed to operate at higher loads and at higher inflation pressures than the corresponding standard tire.

Groove

The space between two adjacent tread ribs.

Innerliner

The layer(s) forming the inside surface of a tubeless tire that contains the inflating medium within the tire.

Innerliner Separation

The parting of the innerliner from cord material in the carcass.

Intended outboard sidewall

The sidewall that contains a white-wall, bears white lettering or bears manufacturer, brand, and/or model name molding that is higher or deeper than the same molding on the other sidewall of the tire or the outward facing sidewall of an asymmetrical tire that has a particular side that must always face outward when mounted on a vehicle.

Light Truck (LT) Tire

A tire designated by its manufacturer as primarily intended for use on lightweight trucks or multipurpose passenger vehicles.

Load Rating

The maximum load that a tire is rated to carry for a given inflation pressure.

Maximum Load Rating

The load rating for a tire at the maximum permissible inflation pressure for that tire.

Maximum Permissible Inflation Pressure

The maximum cold inflation pressure to which a tire may be inflated.

Maximum Loaded Vehicle Weight

The sum of curb weight, accessory weight, vehicle capacity weight, and production options weight.

Measuring Rim

The rim on which a tire is fitted for physical dimension requirements.

Non-pneumatic Rim

A mechanical device which, when a non-pneumatic tire assembly incorporates a wheel, supports the tire, and attaches, either integrally or separably, to the wheel center member and upon which the tire is attached.

Non-pneumatic Spare Tire Assembly

A non-pneumatic tire assembly intended for temporary use in place of one of the pneumatic tires and rims that are fitted to a passenger car in compliance with the requirements of this standard.

Non-pneumatic Tire

A mechanical device which transmits, either directly or through a wheel or wheel center member, the vertical load and tractive forces from the roadway to the vehicle, generates the tractive forces that provide the directional control of the vehicle and does not rely on the containment of any gas or fluid for providing those functions.

Non-pneumatic Tire Assembly

A non-pneumatic tire, alone or in combination with a wheel or wheel center member, which can be mounted on a vehicle.

Normal Occupant Weight

This means 68 kilograms (150 lbs.) times the number of occupants specified in the second column of Table I of 49 CFR 571.110.

Occupant Distribution

The distribution of occupants in a vehicle as specified in the third column of Table I of 49 CFR 571.110.

Open Splice

Any parting at any junction of tread, sidewall, or innerliner that extends to cord material.

Outer Diameter

The overall diameter of an inflated new tire.

Overall Width

The linear distance between the exteriors of the sidewalls of an inflated tire, including elevations due to labeling, decorations, or protective bands or ribs.

Ply

A layer of rubber-coated parallel cords.

Ply Separation

A parting of rubber compound between adjacent plies.

Pneumatic Tire

A mechanical device made of rubber, chemicals, fabric and steel or other materials, that, when mounted on an automotive wheel, provides the traction and contains the gas or fluid that sustains the load.

Production Options Weight

The combined weight of those installed regular production options weighing over 2.3 kilograms (5 lbs.) in excess of those standard items which they replace, not previously considered in curb weight or accessory weight, including heavy duty brakes, ride levelers, roof rack, heavy duty battery, and special trim.

Radial Ply Tire

A pneumatic tire in which the ply cords that extend to the beads are laid at substantially 90 degrees to the centerline of the tread.

Recommended Inflation Pressure

This is the inflation pressure provided by the vehicle manufacturer on the Tire Information label and on the Certification / VIN tag.

Reinforced Tire

A tire designed to operate at higher loads and at higher inflation pressures than the corresponding standard tire.

Rim

A metal support for a tire or a tire and tube assembly upon which the tire beads are seated.

Rim Diameter

This means the nominal diameter of the bead seat.

Rim Size Designation

This means the rim diameter and width.

Rim Type Designation

This means the industry of manufacturer's designation for a rim by style or code.

Rim Width

This means the nominal distance between rim flanges.

Section Width

The linear distance between the exteriors of the sidewalls of an inflated tire, excluding elevations due to labeling, decoration, or protective bands.

Sidewall

That portion of a tire between the tread and bead.

Sidewall Separation

The parting of the rubber compound from the cord material in the sidewall.

Special Trailer (ST) Tire

The "ST" is an indication the tire is for trailer use only.

Test Rim

The rim on which a tire is fitted for testing, and may be any rim listed as appropriate for use with that tire.

Tread

That portion of a tire that comes into contact with the road.

Tread Rib

A tread section running circumstantially around a tire.

Tread Separation

Pulling away of the tread from the tire carcass.

Treadwear Indicators (TWI)

The projections within the principal grooves designed to give a visual indication of the degrees of wear of the tread.

Vehicle Capacity Weight

The rated cargo and luggage load plus 68 kilograms (150 lbs.) times the vehicle's designated seating capacity.

Vehicle Maximum Load on the Tire

The load on an individual tire that is determined by distributing to each axle its share of the maximum loaded vehicle weight and dividing by two.

Vehicle Normal Load on the Tire

The load on an individual tire that is determined by distributing to each axle its share of the curb weight, accessory weight, and normal occupant weight (distributed in accordance with Table I of CRF 49 571.110) and dividing by 2.

Weather Side

The surface area of the rim not covered by the inflated tire.

Wheel Center Member

In the case of a non-pneumatic tire assembly incorporating a wheel, a mechanical device which attaches, either integrally or separably, to the non-pneumatic rim and provides the connection between the non-pneumatic rim and the vehicle; or, in the case of a non-pneumatic tire assembly not incorporating a wheel, a mechanical device which attaches, either integrally or separably, to the non-pneumatic tire and provides the connection between tire and the vehicle.

Wheel-holding Fixture

The fixture used to hold the wheel and tire assembly securely during testing.

TIRE SAFETY—REELSTRONG RIDES ON IT

The National Traffic Safety Administration (NHTSA) has published a brochure (DOT HS 809 361) that discusses all aspects of Tire Safety, as required by CFR 575.6. This brochure is reproduced in part below. It can be obtained and downloaded from NHTSA, free of charge, from the following web site:

http://www.nhtsa.dot.gov/cars/rules/TireSafetyridesonit/tires_index.html

Studies of tire safety show that maintaining proper tire pressure, observing tire and vehicle load limits (not carrying more weight in your vehicle than your tires or vehicle can safely handle), avoiding road hazards, and inspecting tires for cuts, slashes, and other irregularities are the most important things you can do to avoid tire failure, such as tread separation or blowout and flat tires. These actions, along with other care and maintenance activities, can also:

- Improve vehicle handling
- Help protect you and others from avoidable breakdowns and accidents
- Improve fuel economy
- Increase the life of your tires.

This booklet presents a comprehensive overview of tire safety, including information on the following topics:

- Basic tire maintenance
- Uniform Tire Quality Grading System
- Fundamental characteristics of tires
- Tire safety tips.

Use this information to make tire safety a regular part of your vehicle maintenance routine. Recognize that the time you spend is minimal compared with the inconvenience and safety consequences of a flat tire or other tire failure.

SAFETY FIRST—BASIC TIRE MAINTENANCE

Properly maintained tires improve the steering, stopping, traction, and load-carrying capability of your vehicle. Under-inflated tires and overloaded vehicles are a major cause of tire failure. Therefore, as mentioned above, to avoid flat tires and other types of tire failure, you should maintain proper tire pressure, observe tire and vehicle load limits, avoid road hazards, and regularly inspect your tires.

FINDING YOUR VEHICLE'S RECOMMENDED TIRE PRESSURE AND LOAD LIMITS

Tire information placards and vehicle certification labels contain information on tires and load limits. These labels indicate the vehicle manufacturer's information including:

- Recommended tire size
- Recommended tire inflation pressure
- Vehicle capacity weight (VCW—the maximum occupant and cargo weight a vehicle is designed to carry)
- Front and rear gross axle weight ratings (GAWR—the maximum weight the axle systems are designed to carry).

Both placards and certification labels are permanently attached to the trailer near the left front.

UNDERSTANDING TIRE PRESSURE AND LOAD LIMITS

Tire inflation pressure is the level of air in the tire that provides it with load-carrying capacity and affects the overall performance of the vehicle. The tire inflation pressure is a number that indicates the amount of air pressure—measured in pounds per square inch (psi)—a tire requires to be properly inflated. (You will also find this number on the vehicle information placard expressed in kilopascals (kPa), which is the metric measure used internationally.)

Manufacturers of passenger vehicles and light trucks determine this number based on the vehicle's design load limit, that is, the greatest amount of weight a vehicle can safely carry and the vehicle's tire size. The proper tire pressure for your vehicle is referred to as the "recommended cold inflation pressure." (As you will read below, it is difficult to obtain the recommended tire pressure if your tires are not cold.)

Because tires are designed to be used on more than one type of vehicle, tire manufacturers list the "maximum permissible inflation pressure" on the tire sidewall. This number is the greatest amount of air pressure that should ever be put in the tire under normal driving conditions.

CHECKING TIRE PRESSURE

It is important to check your vehicle's tire pressure at least once a month for the following reasons:

- Most tires may naturally lose air over time.
- Tires can lose air suddenly if you drive over a pothole or

other object or if you strike the curb when parking.

- With radial tires, it is usually not possible to determine under-inflation by visual inspection.

For convenience, purchase a tire pressure gauge to keep in your vehicle. Gauges can be purchased at tire dealerships, auto supply stores, and other retail outlets. The recommended tire inflation pressure that vehicle manufacturers provide reflects the proper psi when a tire is cold. The term cold does not relate to the outside temperature. Rather, a cold tire is one that has not been driven on for at least three hours. When you drive, your tires get warmer, causing the air pressure within them to increase. Therefore, to get an accurate tire pressure reading, you must measure tire pressure when the tires are cold or compensate for the extra pressure in warm tires.

STEPS FOR MAINTAINING PROPER TIRE PRESSURE

- Step 1: Locate the recommended tire pressure on the vehicle's tire information placard, certification label, or in the owner's manual.
- Step 2: Record the tire pressure of all tires.
- Step 3: If the tire pressure is too high in any of the tires, slowly release air by gently pressing on the tire valve stem with the edge of your tire gauge until you get to the correct pressure.
- Step 4: If the tire pressure is too low, note the difference between the measured tire pressure and the correct tire pressure. These "missing" pounds of pressure are what you will need to add.
- Step 5: At a service station, add the missing pounds of air pressure to each tire that is under inflated.
- Step 6: Check all the tires to make sure they have the same air pressure (except in cases in which the front and rear tires are supposed to have different amounts of pressure).

If you have been driving your vehicle and think that a tire is under-inflated, fill it to the recommended cold inflation pressure indicated on your vehicle's tire information placard or certification label. While your tire may still be slightly under-inflated due to the extra pounds of pressure in the warm tire, it is safer to drive with air pressure that is slightly lower than the vehicle manufacturer's recommended cold inflation pressure than to drive with a significantly under-inflated tire. Since this is a temporary fix, don't forget to recheck and adjust the tire's pressure when you can obtain a cold reading.

TIRE SIZE

To maintain tire safety, purchase new tires that are the same size as the vehicle's original tires or another size recommended by the manufacturer. Look at the tire information placard, the owner's manual, or the sidewall of the tire you are replacing to find this information. If you have any doubt about the correct size to choose, consult with Reelstrong.

TIRE TREAD

The tire tread provides the gripping action and traction that prevent your vehicle from slipping or sliding, especially when the road is wet or icy. In general, tires are not safe and should be replaced when the tread is worn down to 1/16 of an inch. Tires have built-in tread-wear indicators that let you know when it is time to replace your tires. These indicators are raised sections spaced intermittently in the bottom of the tread grooves. When they appear "even" with the outside of the tread, it is time to replace your tires. Another method for checking tread depth is to place a penny in the tread with Lincoln's head upside down and facing you. If you can see the top of Lincoln's head, you are ready for new tires.

TIRE BALANCE AND WHEEL ALIGNMENT

To avoid vibration or shaking of the vehicle when a tire rotates, the tire must be properly balanced. This balance is achieved by positioning weights on the wheel to counterbalance heavy spots on the wheel-and-tire assembly. A wheel alignment adjusts the angles of the wheels so that they are positioned correctly relative to the vehicle's frame. This adjustment maximizes the life of your tires. These adjustments require special equipment and should be performed by a qualified technician.

TIRE REPAIR

The proper repair of a punctured tire requires a plug for the hole and a patch for the area inside the tire that surrounds the puncture hole. Punctures through the tread can be repaired if they are not too large, but punctures to the sidewall should not be repaired. Tires must be removed from the rim to be properly inspected before being plugged and patched.

TIRE FUNDAMENTALS

Federal law requires tire manufacturers to place standardized information on the sidewall of all tires. This information identifies and describes the fundamental characteristics of the tire and also provides a tire identification number for safety standard certification and in case of a recall. Information on Passenger Vehicle Tires

Please refer to the diagram below.

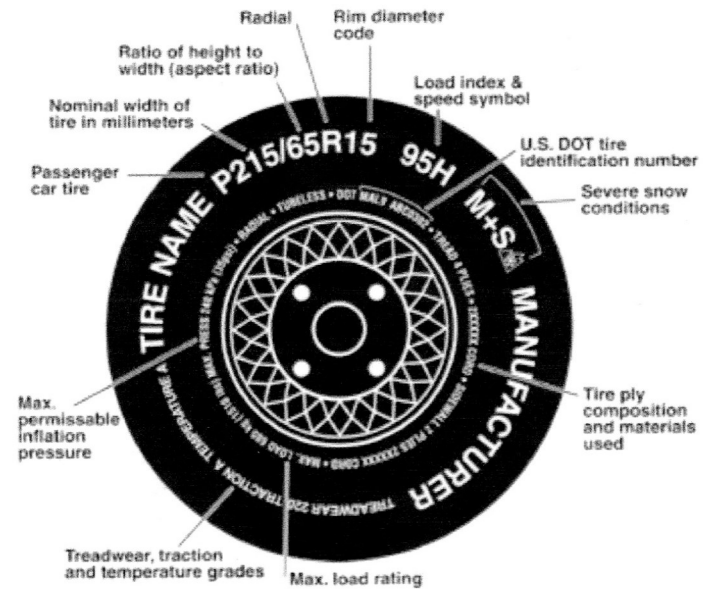

P

The "P" indicates the tire is for passenger vehicles.

Next Number

This three-digit number gives the width in millimeters of the tire from sidewall edge. In general, the larger the number, the wider the tire.

Next Number

This two-digit number, known as the aspect ratio, gives the tire's ratio of height to width. Numbers of 70 or lower indicate a short sidewall for improved steering response and better overall handling on dry pavement.

R

The "R" stands for radial. Radial ply construction tires has been the industry standard for the past 20 years.

Next Number

This two-digit number is the wheel or rim diameter in inches. If you change your wheel size, you will have to purchase new tires to match the wheel diameter.

Tires for light trucks have other markings besides those found on the sidewalls of passenger tires.

LT

The "LT" indicates the tire is for light trucks or trailers.

ST

An "ST" is an indication the tire is for trailer use only.

Max. Load Dual kg (lbs) at kPa (psi) Cold

This information indicates the maximum load and tire pressure when the tire is used as a dual, that is, when four tires are put on each rear axle (a total of six or more tires on the vehicle).

Max. Load Single kg (lbs) at kPa (psi) Cold

This information indicates the maximum load and tire pressure when the tire is used as a single.

Load Range

This information identifies the tire's load-carrying capabilities and its inflation limits.

TIRE SAFETY TIPS

Preventing Tire Damage

- Slow down if you have to go over a pothole or other object in the road.
- Do not run over curbs or other foreign objects in the roadway, and try not to strike the curb when parking.

Tire Safety Checklist

- Check tire pressure regularly (at least once a month), including the spare.
- Inspect tires for uneven wear patterns on the tread, cracks, foreign objects, or other signs of wear or trauma.
- Remove bits of glass & foreign objects wedged in the tread.
- Make sure your tire valves have valve caps.
- Check tire pressure before going on a long trip.
- Do not overload your vehicle. Check the Tire Information and Loading Placard or User's Manual for the maximum recommended load for the vehicle.

COUPLING TO THE TOW VEHICLE

Follow all of the safety precautions and instructions in this manual to ensure safety of persons, cargo, and satisfactory life of the trailer.

USE AN ADEQUATE TOW VEHICLE AND HITCH

If the vehicle or hitch is not properly selected and matched to the Gross Vehicle Weight Rating (GVWR) of your trailer, you can cause an accident that could lead to death or serious injury. If you already have a tow vehicle, know your vehicle tow rating, and Gross Combination Weight Rating (GCWR) and make certain the trailer's rated capacity is less than or equal to the tow vehicle's rated towing capacity. If you already have (or plan to buy) a trailer, make certain that the tow rating of the tow vehicle is equal to or greater than the GVWR of the trailer, and that the GCWR will be within limits.

^DANGER

Use of a hitch with a load rating less than the load rating of the trailer can result in loss of control and may lead to death or serious injury.

Use of a tow vehicle with a towing capacity less than the load rating of the trailer can result in loss of control, and may lead to death or serious injury. Be sure your hitch and tow vehicle are rated for the Gross Vehicle Weight Rating of your trailer.

TRAILER INFORMATION

Certification / VIN Label

The location of the trailer "Certification / VIN Tag" is shown as the sticker on the right below.

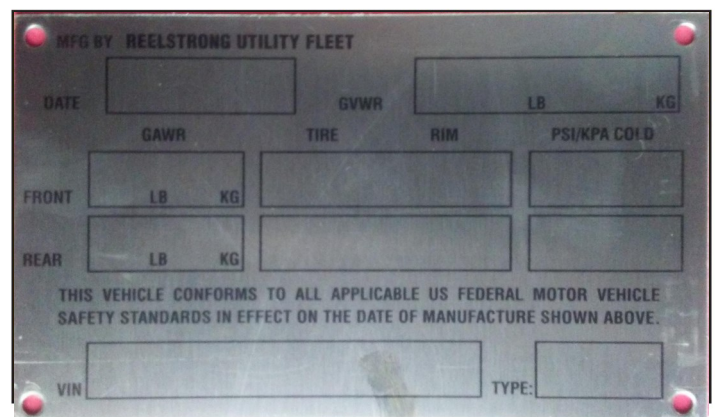

Keep a record of the date and approximate mileage when you check the lug nut torque. Note any lug nut that has lost torque. Investigate the reason(s) if the lug nut torque is not maintained after more than one re-torque application, because this indicates there is something wrong with the lug nuts, nut studs, wheels and/or hubs and should be corrected.

Contact your dealer or Reelstrong immediately if you experience any persistent lug nut loosening or any other lug, wheel or axle problems.

In the event of a wheel separation incident, notify the vehicle manufacturer and dealer. Seek prompt professional assistance in assessing the trailer and its gear, and retain, but don't re-use involved lugs, wheels and studs. Don't repair or service the trailer yourself. Call a trained technician.

Lug Nut Torque—Steel Wheels		
Axle Rating Pounds	Stud Size	Dry Torque Foot-Pounds
3,500 to 7,000	$\frac{1}{2}$ inch	90-120 (max) ft pounds
8,000	$\frac{9}{16}$ inch	170 (max) ft pounds
9,000	$\frac{5}{8}$ inch	325 (max) ft pounds

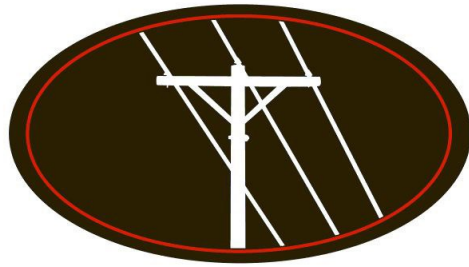

REELSTRONG® ***UTILITY FLEET***

Reel, Pole and Gas Trailers using ACME-Clamp™, Safelock™, and
Securelock™ Technologies

**GENERAL ARRANGEMENT,
BILL OF MATERIALS &
SUBASSEMBLY DRAWINGS
SECTION**

SL20K-T SINGLE REEL TRAILER

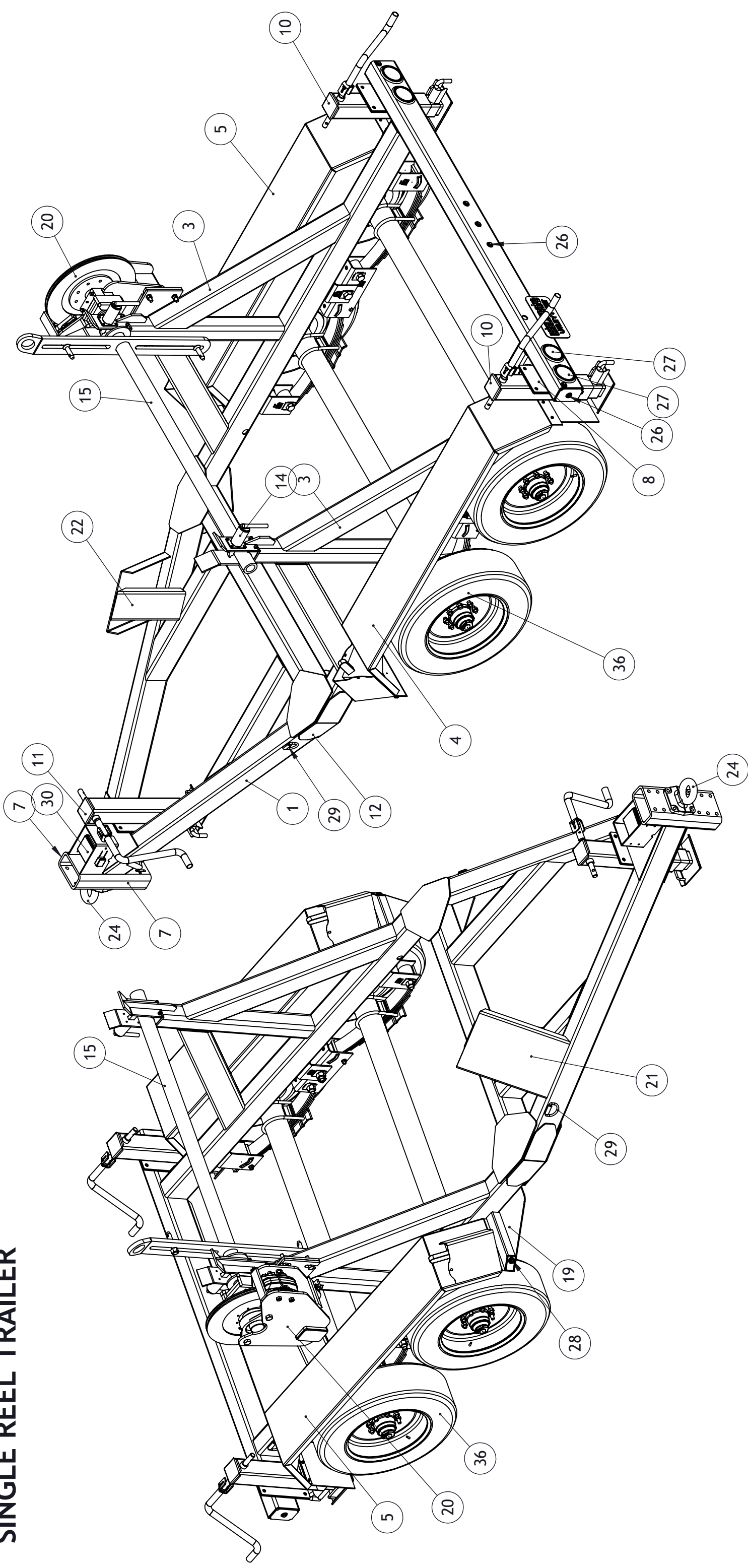

UNLESS OTHERWISE SPECIFIED:

PROPRIETARY AND CONFIDENTIAL
 THE INFORMATION CONTAINED IN THIS DRAWING IS THE SOLE PROPERTY OF ReelStrong, Inc. ANY REPRODUCTION IN PART OR AS A WHOLE WITHOUT THE WRITTEN PERMISSION OF ReelStrong, Inc. IS PROHIBITED.

DIMENSIONS ARE IN INCHES
 TOLERANCE LIMITS
 ANGULAR = $\pm 1.0^\circ$
 DECIMAL .X = ± 0.060
 DECIMAL .XX = ± 0.010
 DECIMAL .XXX = ± 0.005



MATERIAL:
 FINISH:
 APPROX WEIGHT:
 LBS
 DRAWN:

TITLE: SL20K-T Single Reel Trailer	
DATE: 3/17/2018	CUSTOMER:
DRWN: 3/17/2018	DWG. NO.:
DO NOT SCALE DRAWING	
SHEET 1 OF 5	RTD-0000 - TopLevel
REV	1

1 2 3 4 5 6 7 8

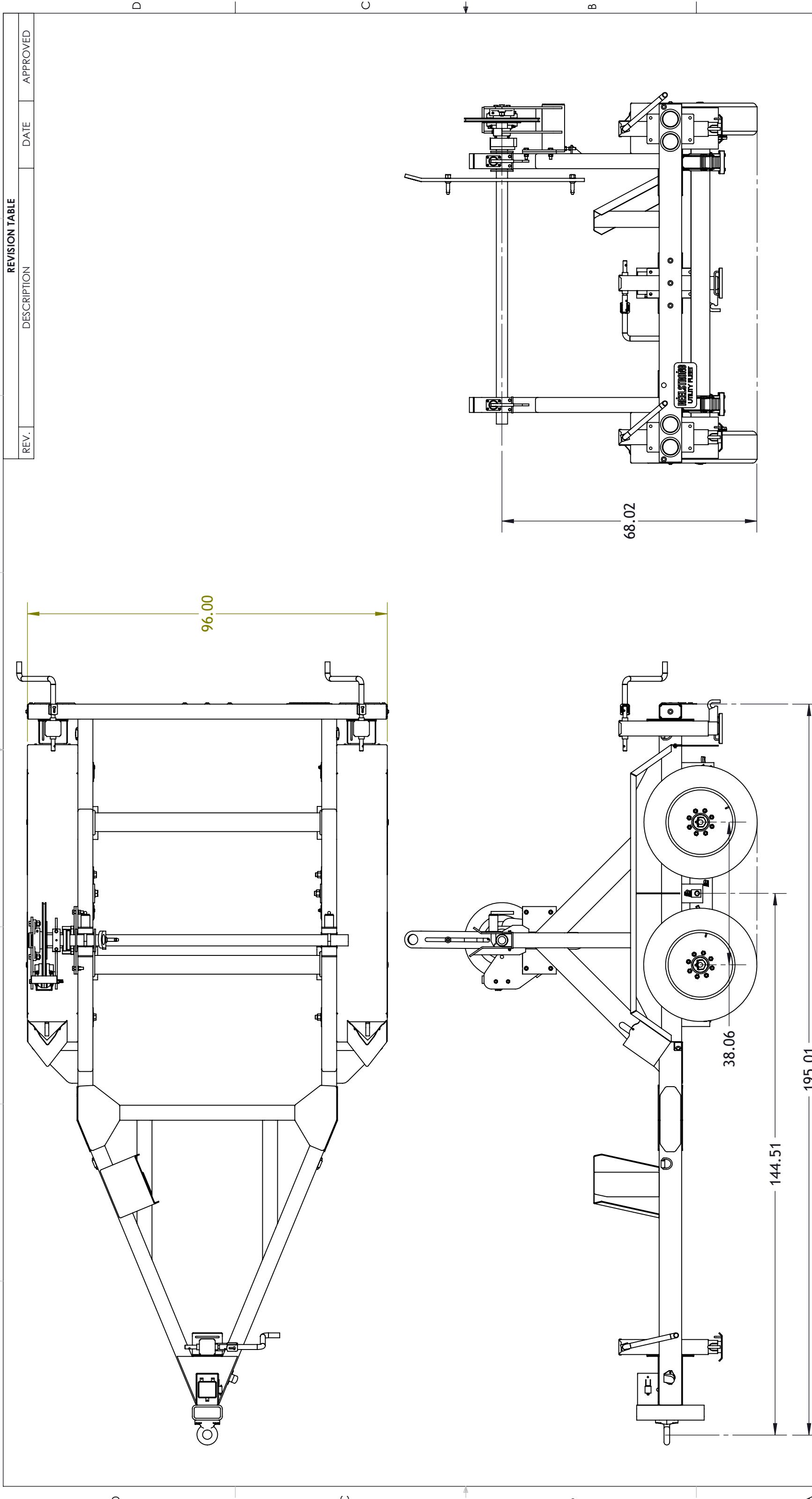

REVISION TABLE			
REV.	DESCRIPTION	DATE	APPROVED

<p>UNLESS OTHERWISE SPECIFIED:</p> <p>PROPRIETARY AND CONFIDENTIAL</p> <p>THE INFORMATION CONTAINED IN THIS DRAWING IS THE SOLE PROPERTY OF ReelStrong, Inc. ANY REPRODUCTION IN PART OR AS A WHOLE WITHOUT THE WRITTEN PERMISSION OF ReelStrong, Inc. IS PROHIBITED.</p>		<p>DIMENSIONS ARE IN INCHES</p> <p>TOLERANCE LIMITS</p> <p>ANGULAR = $\pm 1.0^\circ$</p> <p>DECIMAL .X = ± 0.060</p> <p>DECIMAL .XX = ± 0.010</p> <p>DECIMAL .XXX = ± 0.005</p>	
<p>BEELSTRONG UTILITY FLEET</p> <p>FINLESS REEL POLE PULLING TRAILERS AND SERVICE</p> <p>283 S. Oak St., Manheim, PA 17545</p> <p>V: 484-889-6048 F: 888-380-3932 info@reelstrongutility.com</p>		<p>MATERIAL:</p> <p>FINISH:</p> <p>APPROX WEIGHT: LBS</p> <p>DRWN:</p>	
<p>TITLE:</p> <p>SL20K-T</p> <p>SINGLE REEL TRAILER</p>		<p>CUSTOMER</p> <p>DATE: 3/17/2018</p> <p>DO NOT SCALE DRAWING</p>	
<p>SHEET 2 OF 5</p>		<p>RTD-0000 - TopLevel</p>	
<p>REV</p> <p>1</p>		<p>1</p>	

8

D

C

B

A

8

7

6

5

4

3

2

1

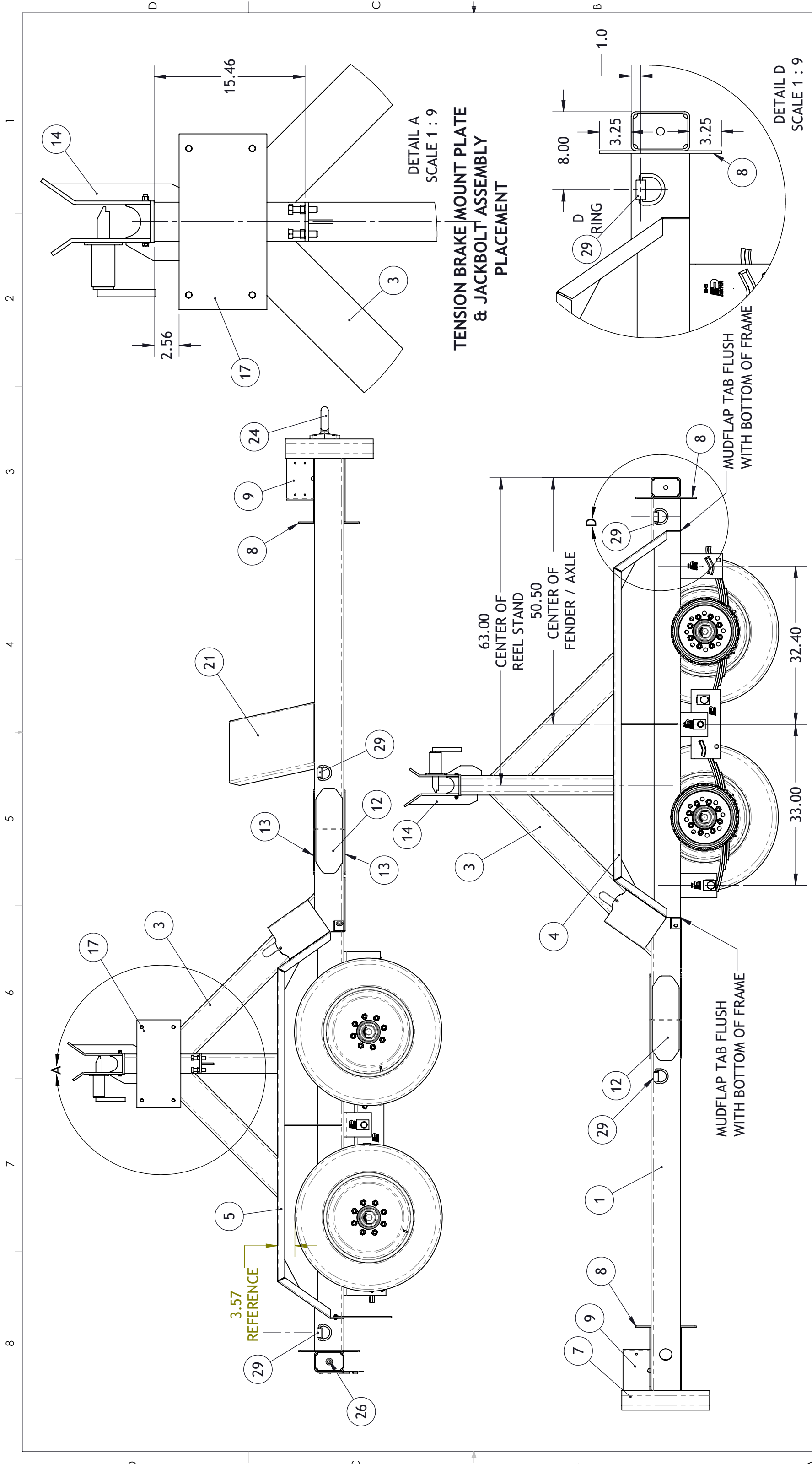

**TENSION BRAKE MOUNT PLATE
& JACKBOLT ASSEMBLY
PLACEMENT**

DETAIL A
SCALE 1 : 9

DETAIL D
SCALE 1 : 9

UNLESS OTHERWISE SPECIFIED:

PROPRIETARY AND CONFIDENTIAL

THE INFORMATION CONTAINED IN THIS DRAWING IS THE SOLE PROPERTY OF ReelStrong, Inc. ANY REPRODUCTION IN PART OR AS A WHOLE WITHOUT THE WRITTEN PERMISSION OF ReelStrong, Inc. IS PROHIBITED.

DIMENSIONS ARE IN INCHES
TOLERANCE LIMITS
ANGULAR = $\pm 1.0^\circ$
DECIMAL .X = ± 0.060
DECIMAL .XX = ± 0.010
DECIMAL .XXX = ± 0.005

REELSTRONG
UTILITY FLEET

PINLESS REEL POLE PULLING TRAILERS AND SERVICE
283 S. Oak St., Manheim, PA 17545
V: 484-889-8048 F: 888-380-3932 info@reelstrongutility.com

MATERIAL:
FINISH:
APPROX WEIGHT:
LBS
DRAWN:
DATE: 3/17/2018
CUSTOMER:
DO NOT SCALE DRAWING

TITLE: SL20K-T Single Reel Trailer Chassi

SHEET 3 OF 5
RTD-0000 - TopLevel
REV 1

ITEM NO.	Vendor	QTY.	PART NUMBER	DESCRIPTION	Material	Length	WIDTH	Thickness	STEP 1	STEP 2	STEP 3
1	Alro	1	SL20KT-0100	Frame Weldment - see weldment cutlist	Rect Tube 6.000 x 4.000 x .250				Saw / Miter	Plasma	
2	Alro	2	SL20KT-0097	Bumper Cap	Sheet Steel, 0.250	5.625	3.625		Plasma		
3	Alro	2	SL20KT-0101	Tower Assy, Reel Support	Galvanized Steel				Saw/Miter		
4		1	SL20KT-01004	Fender Assy, Driver Side							
5		1	MirrorSL20KT-01004								
6		2	SL20KT-0021	GUSSET, TONGUE TO HITCH TUBE	Sheet Steel, 0.250	16.077	13.000	0.250	PLASMA		
7	ALRO	1	SL20KT-0008	HITCH TUBE	Rect Tube, 8.000 x 4.000 x 0.500	18.000			SAW	PLASMA	
8	Alro	3	SL20KT-0099	Mounting Plate, Front Jack	Sheet, 0.250	7.875	12.500	0.250	Plasma		
9		1	BATTERY GUARD	BATTERY GUARD, BREAKAWAY	SHEET, 0.250	22.368	5.500		PLASMA	BEND	
10		2	5016-0000-RearJack	Rear Jack Assembly w. Plate							
11		1	5016-0000-FrontJack	Front Stabilizer							
12	ALRO	2	SL20KT-0102	FISH PLATE	Sheet Steel, 0.250				PLASMA	BEND	
13	Alro	4	SL20KT-0103 GUSSET	Gusset	Sheet Steel 0.250				Plasma		
14		2	RS01-0403	Safelock Assy							
15	xxx	1	SL20KT-0500	Reel Shaft Assy							
16		1	SL20KT-0514	JACKING BOLT ASSY							
17	Alro	1	SL20KT-0031	Mounting Plate Tension Brake	Sheet, 0.500				Plasma		
18	Alro	1	SL20KT-0058	Gusset Step Tread Plate	Tread Plate, 0.250				Plasma	Bend	
19	Alro	1	SL20KT-0058Mirror	Gusset Step Tread Plate	Tread Plate, 0.250				Plasma		
20		1	SL20KT-TensionBrake-1000	Assembly, Tension Brake							
21	Alro	1	SL20KT-0081	Operators Station	Sheet Steel 0.250				Plasma	Bend	
22	Alro	1	SL20KT-0083	Support, Operators Station	Sheet Steel 0.250				Plasma	Bend	
23		2	MudFlapAssy	Mud Flap Assy							
24	Nuera	1	17-111	Pintle					PURCHASED		
25	Nuera	7	12-11-404	7-way Socket							
26	Nuera	7	11-267-OP	3/4" Red LED Light					Purchase		
27	Nuera	4	11-900-OP, 11-102-2-OP, and 11-107-P-OP	4" Red LED Taillight, 4" Grommet, and Pigtail					Purchase		
28	Nuera	6	11-268-OP	3/4 Amber Marker Light							
29	Nuera	4	08-410	5/8 D-ring					PURCHASED		
30	Nuera	1	20-236-4L (Part 1)	Breakaway Kit - Battery					PURCHASED		
31	Nuera	1	20-236-4L (Part 2)	Breakaway Kit - Kill Switch	Material <not specified>				PURCHASED		
32		4	HHBOLT 0.6250-18x2.5x1.25-N								
33		4	LW, 5/8 NOM DIA.	LOCK WASHER, 5/8 NOM DIA.							
34		4	HNUT 0.6250-18-D-N								
35		1	License Plate	License Plate							
36		1	10KGD Axle Assembly	10KGD Axle Assembly							

TITLE: **SL20K-T SINGLE REEL TRAILER BOM**

DATE: 3/17/2018 CUSTOMER: RTD-0000 - TopLevel

SHEET 5 OF 5 DWG. NO. REV: **1**



AEEELSTRONG
UTILITY FLEET
PINLESS REEL POLE PULLING TRAILERS AND SERVICE
283 S. Oak St., Manheim, PA, 17545
V: 484-889-6048 F: 888-380-3932 info@reelstrongfleet.com

UNLESS OTHERWISE SPECIFIED:

PROPRIETARY AND CONFIDENTIAL

THE INFORMATION CONTAINED IN THIS DRAWING IS THE SOLE PROPERTY OF Reelstrong, Inc. ANY REPRODUCTION IN PART OR AS A WHOLE WITHOUT THE WRITTEN PERMISSION OF Reelstrong, Inc. IS PROHIBITED.

DIMENSIONS ARE IN INCHES
TOLERANCE LIMITS
ANGULAR = ± 1.0°
DECIMAL .X = ±0.060
DECIMAL .XX = ±0.010
DECIMAL .XXX = ±0.005

DO NOT SCALE DRAWING

8 7 6 5 4 3 2 1

ITEM NO.	QTY.	Vendor	VendorNO	PART NUMBER	DESCRIPTION	STEP 1	STEP 2	STEP 3
1	1			SL20KT-TensionBrake-0100	Frame Assy, Tension Brake	See Drawing		
2	1			SL20KT-0300	Bearing Block Assy, Top			
3	1			SL20KT-TB-0061	Hub Assy, Tension Brake			
4	1	The Big Bearing Store	UCFL215-48	LA24K - UCFL215-48	Bearing, 3" FLANGE BEARING	Purchase		
5	1	HYDRO AIR	02-520-265	02-520-260	DISK BRAKE CALIPER	PURCHASED		
6	1	Stockbridge Engineering	300320	300320-1	20" Aluminum Bronze Disc, 1" thk	Purchase		
7	2	MCMASTER	91247A459	91247A459	HHCS 5/8-18 X 8-1/2, PRT THRD, GR5	Purchase		
8	2			HHBOLT 0.7500-16x2.5x1.375-N				
9	2			LW 3/4 NOM DIA.	LOCK WASHER, 3/4 NOM DIA.			
10	2			HHNUT 0.7500-16-B-N				
11	3			HNUT 9/16-12 LUG NUT	HEX HEAD LUG NUT, 9/16-12 LUG NUT			

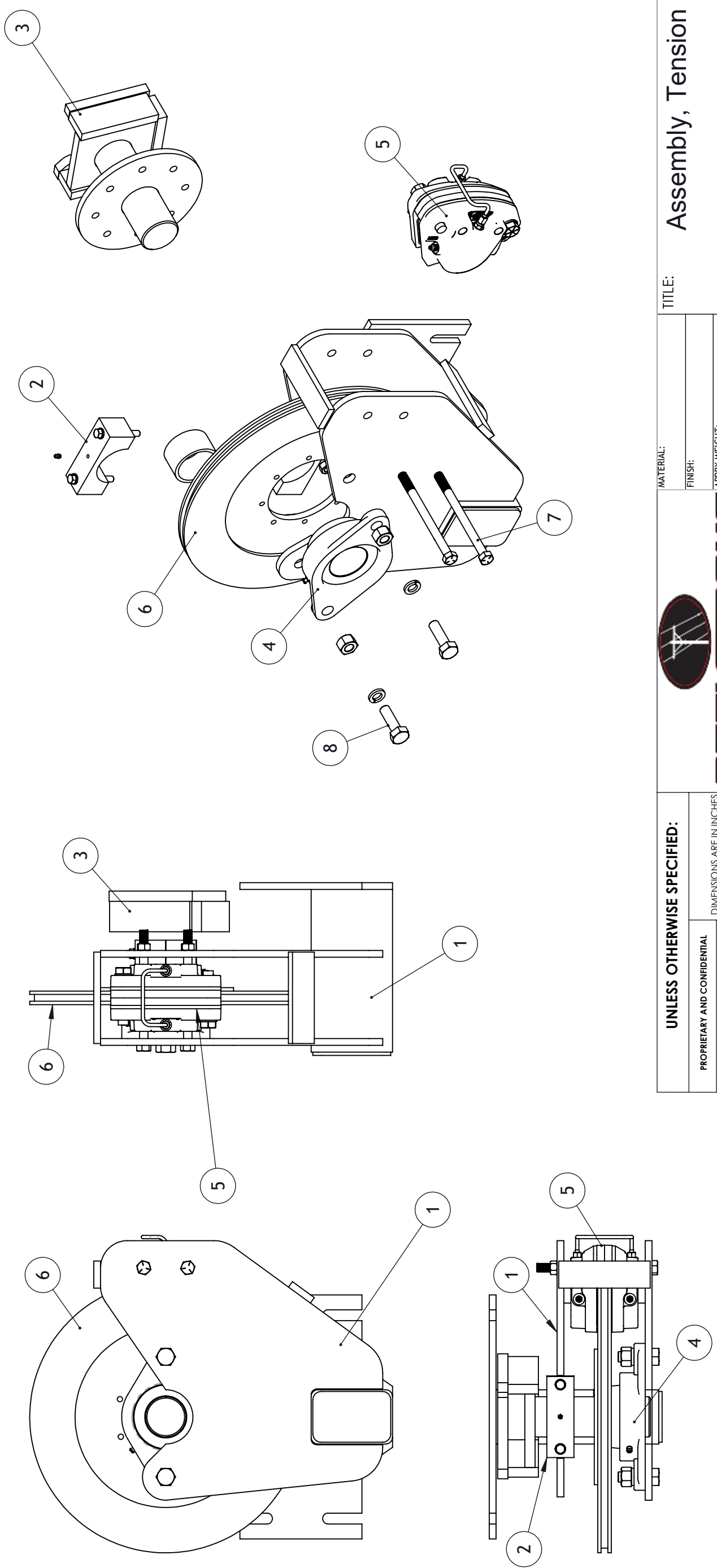

UNLESS OTHERWISE SPECIFIED: PROPRIETARY AND CONFIDENTIAL THE INFORMATION CONTAINED IN THIS DRAWING IS THE SOLE PROPERTY OF Reelstrong, Inc. ANY REPRODUCTION IN PART OR AS A WHOLE WITHOUT THE WRITTEN PERMISSION OF Reelstrong, Inc. IS PROHIBITED.		DIMENSIONS ARE IN INCHES TOLERANCE LIMITS ANGULAR = ± 1.0° DECIMAL .X = ±0.060 DECIMAL .XX = ±0.010 DECIMAL .XXX = ±0.005	
REELSTRONG® UTILITY FLEET PINLESS REEL POLE PULLING TRAILERS AND SERVICE 283 S. Oak St., Manheim, PA 17545 V: 484-889-6048 F: 888-380-3932 info@reelstrongutility.com		MATERIAL: FINISH: APPROX WEIGHT: LBS DRAWN: DO NOT SCALE DRAWING	
TITLE: Assembly, Tension Brake		DATE: 3/17/2018 CUSTOMER: RTD-TensionBrake-1000 DWG. NO.: SHEET 1 OF 1	
REV: 1		SHEET 1 OF 1	

8 7 6 5 4 3 2 1

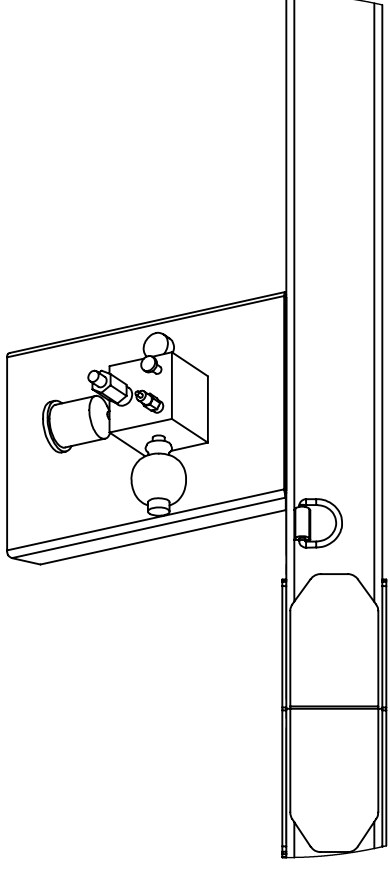

TENSION BRAKE HYDRAULIC PUMP
DETAIL
SCALE 1 : 12



Hand Pump to Adjust Tension Brake Pressure
Vendor: Hydroair
P/N: HA65396-2001-1808 (90169554-E22)

UNLESS OTHERWISE SPECIFIED:

PROPRIETARY AND CONFIDENTIAL

THE INFORMATION CONTAINED IN THIS DRAWING IS THE SOLE PROPERTY OF ReelStrong, Inc. ANY REPRODUCTION IN PART OR AS A WHOLE WITHOUT THE WRITTEN PERMISSION OF ReelStrong, Inc. IS PROHIBITED.

DIMENSIONS ARE IN INCHES
 TOLERANCE LIMITS
 ANGULAR = $\pm 1.0^\circ$
 DECIMAL .X = ± 0.060
 DECIMAL .XX = ± 0.010
 DECIMAL .XXX = ± 0.005

REELSTRONG
 UTILITY FLEET

PINLESS REEL POLE PULLING TRAILERS AND SERVICE
 283 S. Oak St., Manheim, PA 17545
 V: 484-889-8048 F: 888-380-3932 info@reelstrongfleet.com

MATERIAL:
 FINISH:
 APPROX WEIGHT:
 LBS
 DRAWN:
 DATE: 7/26/2018
 CUSTOMER:
 DWG. NO.: SL20KT-Hand Pump Detail
 SHEET 1 OF 1

TITLE: **SL20K-T Single Reel Trailer**
Tension Brake Hydraulic Pump

ITEM NO.	Vendor	VendorNO	PART NUMBER	DESCRIPTION	Material	Length	WIDTH	Thickness	STEP 1	STEP 2	STEP 3
1	Alro		RS01-0405	GUSSET	Sheet, 1/2	7 1/8	2	1/2	Plasma		
2	ARK Precision		RS01-0613-35	LATCH PLATE	Laser Sheet, 3/8	8	3 1/2		Laser	Tap	
3	Alro		RS01-0404	END CAP	Sheet, 3/8	4 1/4	4 1/4	3/8	PLASMA		
4	Alro Plastics		RS01-0406	SPOOLBAR SEAT	NYLATRON GSM	3 1/2	2 9/16	2	Waterjet	Drill	
5			RS01-0313-20	Arbor Spindle Guide Weldment							
	Alro		RS01-0613-36	SADDLE PLATE, BENT	Sheet, 3/8	11 7/8	5 1/4	3/8	Plasma	Bend	
	Alro		RS01-0313-02	GUSSET	Sheet, 3/8	1 3/4	1 3/4		Plasma		
6			LW, 3/8 NOM DIA.	LOCK WASHER, 3/8 NOM DIA.							
7			HNUT 3/8-16 GRADE 5	HEX NUT, 3/8-16 GR-5							
8			HHCS 3/8-16 X 5 PRT THRD GRADE 5	HEX HEAD CAP SCREW, 3/8-16 X 5 PRT THRD, GR-5	Grade 5						
9			Safelock™-0001	Safelock™ Assy							
	McMaster Carr	96485K125		1.937 O/Dia X 4.00 Lg X 0.148 Wire Dia					Purchase		
	McMaster Carr	92383A754		Roll Pin / Slotted Spring Pin - 1/4 Dia X 2 Lg Stainless Steel Roll Pin Plain					Purchase		

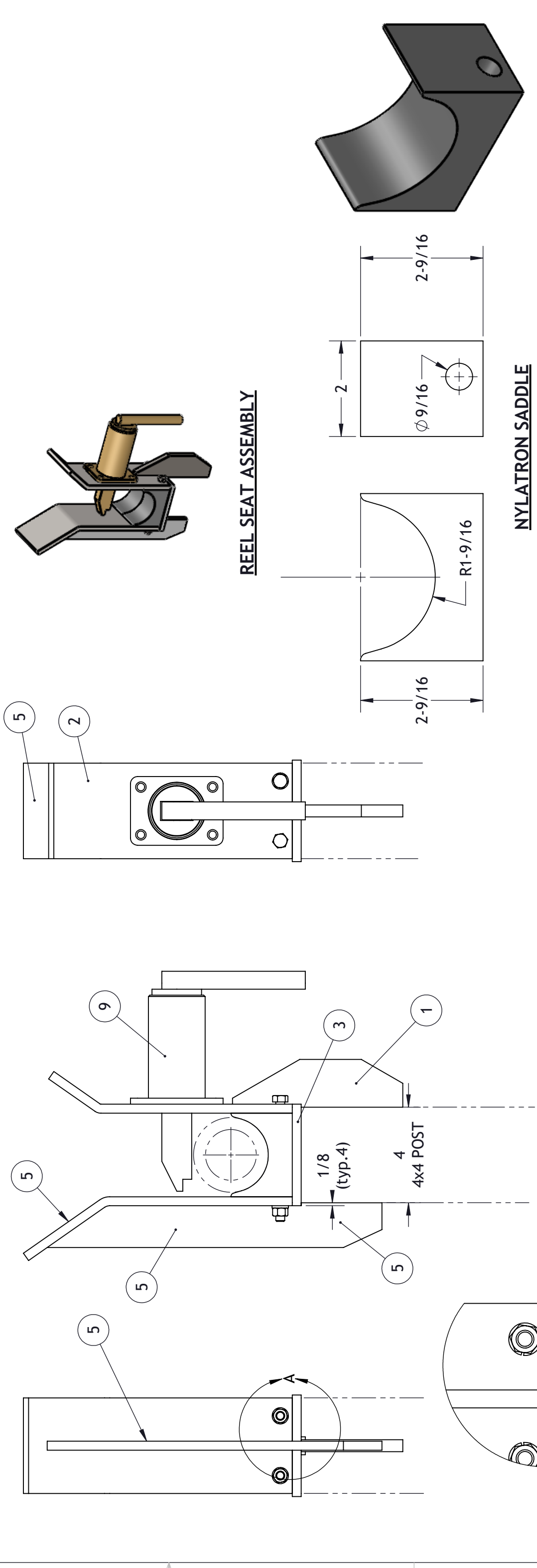

UNLESS OTHERWISE SPECIFIED:

PROPRIETARY AND CONFIDENTIAL

THE INFORMATION CONTAINED IN THIS DRAWING IS THE SOLE PROPERTY OF Reelstrong, Inc. ANY REPRODUCTION IN PART OR AS A WHOLE WITHOUT THE WRITTEN PERMISSION OF Reelstrong, Inc. IS PROHIBITED.

DIMENSIONS ARE IN INCHES
TOLERANCE LIMITS
ANGULAR = ± 1.0°
DECIMAL .X = ±0.060
DECIMAL .XX = ±0.010
DECIMAL .XXX = ±0.005

REELSTRONG®
UTILITY FLEET
PINLESS REEL POLE PULLING TRAILERS AND SERVICE
283 S. Oak St., Manheim, PA 17545
V: 484-889-6048 F: 888-380-3932 info@reelstrongutility.com

MATERIAL: _____
FINISH: _____
APPROX WEIGHT: 9465.9458 LBS
DRAWN: _____
DATE: 3/17/2018
CUSTOMER: _____
DWG. NO. RS01-0403

TITLE: Safelock Assy

DO NOT SCALE DRAWING

SHEET 1 OF 1

REV 1

1 2 3 4 5 6 7 8

ITEM NO.	Vendor	Vendor NO	QTY.	PART NUMBER	DESCRIPTION	Material	Length	WIDTH	Thickness	STEP 1	STEP 2	STEP 3
1	Alro		1	RSL20KT-0501	CL96 Spool Bar Center	DOM, 3.00 OD, 2.00 ID	75.00			Saw		
2	Alro		1	SL20KT-0504	Drive Bar	Sheet Steel, 0.75	24.00	4.50		Plasma	Bend	
3	Alro		1	SL20KT-0507	Plate. Drive Bar	Sheet Steel, 0.88				Plasma		
4	Alro		2	SL20KT-506	Guide Plates, Reel Bar	Sheet Steel, 0.38				Plasma		
5	PaulB		2	002000	Drive Pin, PaulB 002000		2.88		.88	Purchase		
6			2	HTNUT 0.8750-9-B-N								

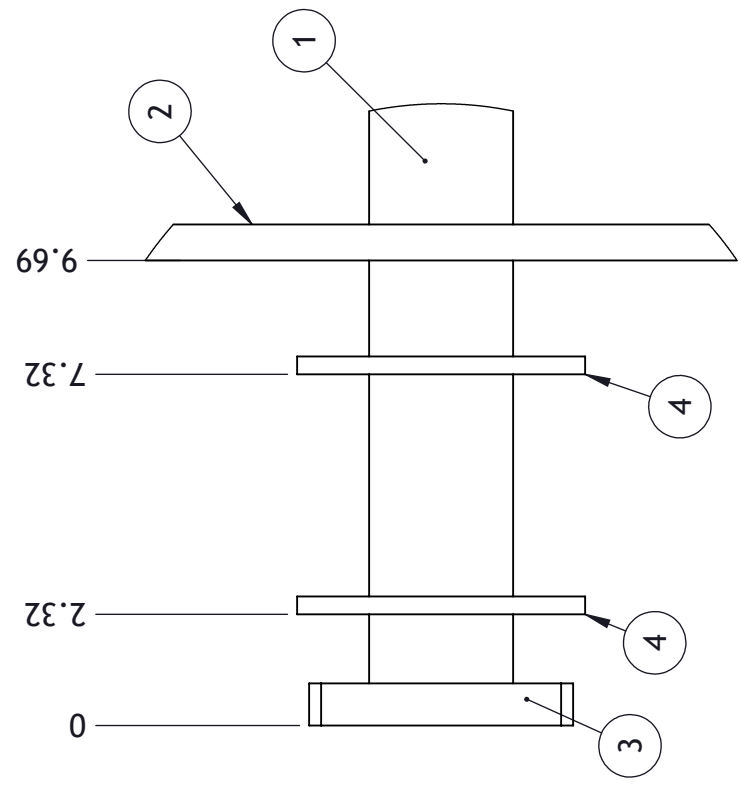
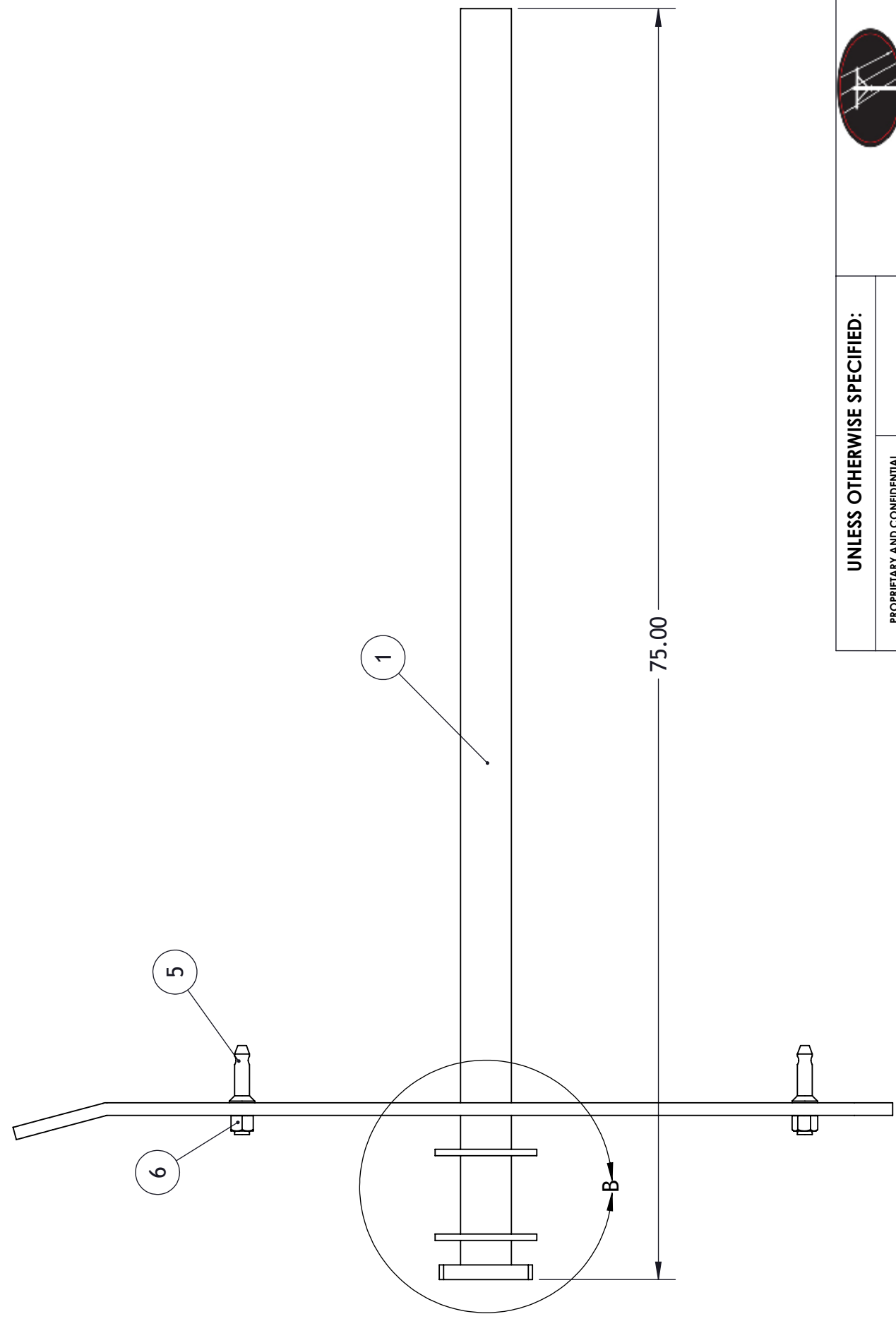

DETAIL B
SCALE 1 : 4

<p>UNLESS OTHERWISE SPECIFIED:</p> <p>PROPRIETARY AND CONFIDENTIAL</p> <p>THE INFORMATION CONTAINED IN THIS DRAWING IS THE SOLE PROPERTY OF ReelStrong, Inc. ANY REPRODUCTION IN PART OR AS A WHOLE WITHOUT THE WRITTEN PERMISSION OF ReelStrong, Inc. IS PROHIBITED.</p>		<p>DIMENSIONS ARE IN INCHES</p> <p>TOLERANCE LIMITS</p> <p>ANGULAR = ± 1.0°</p> <p>DECIMAL .X = ±0.060</p> <p>DECIMAL .XX = ±0.010</p> <p>DECIMAL .XXX = ±0.005</p>		<p>REELSTRONG®</p> <p>UTILITY FLEET</p> <p>PINLESS REEL POLE PULLING TRAILERS AND SERVICE</p> <p>283 S. Oak St., Manheim, PA 17545</p> <p>V: 484-889-8048 F: 888-380-3932 info@reelstrongutility.com</p>		<p>MATERIAL:</p> <p>FINISH:</p> <p>APPROX WEIGHT: 133.99262669 LBS</p> <p>DRWN:</p>		<p>TITLE: Reel Shaft Assy</p>	
<p>DATE: 3/18/2018</p>				<p>CUSTOMER</p>		<p>REV</p>			
<p>DO NOT SCALE DRAWING</p>				<p>SHEET 1 OF 1</p>		<p>DWG. NO. RDT20-0500</p>			

D C B A

BILL OF MATERIALS							
ITEM	PART NUMBER	DESCRIPTION	MATERIAL	QTY	STEP 1	STEP 2	STEP 3
1	SL20KT-0715A	CLAMP BLOCK	SHEET, 1.500	1	Waterjet	DRILL/TAP	
2	SL20KT-0716	LIFT LUG	Rnd Bar, 1.250	1	Saw	Bend	
3	SL20KT-0715B	CLAMP BLOCK, THREADED	SHEET, 1.500	1	Waterjet	DRILL/TAP	
4	HBOLT 0.7500-10x5.5x1.75-N			1			
5	HBOLT 0.7500-16x5.5x1.75-N			1			
6	LW 3/4 NOM DIA.	LOCK WASHER, 3/4 NOM DIA.		2			

WELD THESE THREE TOGETHER

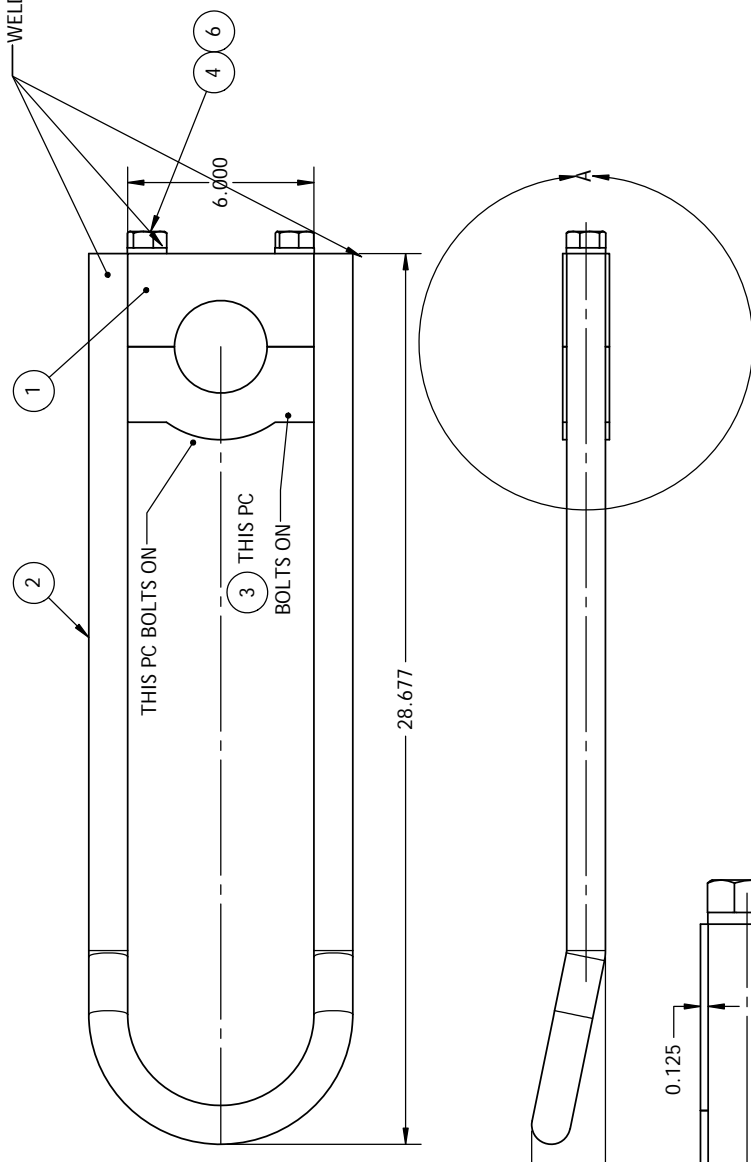

DETAIL A
SCALE 1 : 2

 <p>AELSTRONG UTILITY FLEET FINESS REEL POLE PULLING TRAILERS AND SERVICE 288 S. Oak St., Marheim, PA 17345 V. 484-899-5048 F. 888-388-3932 www.aelstrongfleet.com</p>		<p>UNLESS OTHERWISE SPECIFIED: PROPRIETARY AND CONFIDENTIAL THE INFORMATION CONTAINED IN THIS DRAWING IS THE SOLE PROPERTY OF Aelstrong, Inc. ANY REPRODUCTION OR TRANSMISSION OF THIS DRAWING WITHOUT THE WRITTEN PERMISSION OF Aelstrong, Inc. IS PROHIBITED.</p>		<p>DIMENSIONS ARE IN INCHES TOLERANCE LIMITS ANGULAR = ± 1.0° DECIMAL X = ± 0.040 DECIMAL XX = ± 0.010 DECIMAL .XX = ± 0.005</p>		<p>MATERIAL: _____ FINISH: _____ APPROX WEIGHT: 31.5439 LBS DRAWN: _____</p>		<p>TITLE: ASSEMBLY, LIFTING LUG</p>	
DO NOT SCALE DRAWING				DATE: 2/8/2017	CUSTOMER: _____	REV: _____		DRAWG. NO.: RTD-0714	
SHEET 1 OF 1								1	

1 2 3 4 5 6 7 8

ITEM NO.	Vendor	NO 5016-Front Jack/QTY.	PART NUMBER	DESCRIPTION	Material	Length	WIDTH	Thickness	STEP 1	STEP 2	STEP 3
1	Nuera	19-570-SP	5016-0012(Default_As Machined_) -1	12K Jack					Purchase		
2	Alro		SL20KT-0099	Mounting Plate, Front Jack	Sheet, 1/4	7 7/8	12 1/2	1/4	Plasma		
3			5016-0013	Extension, Jack Handle ASSY							

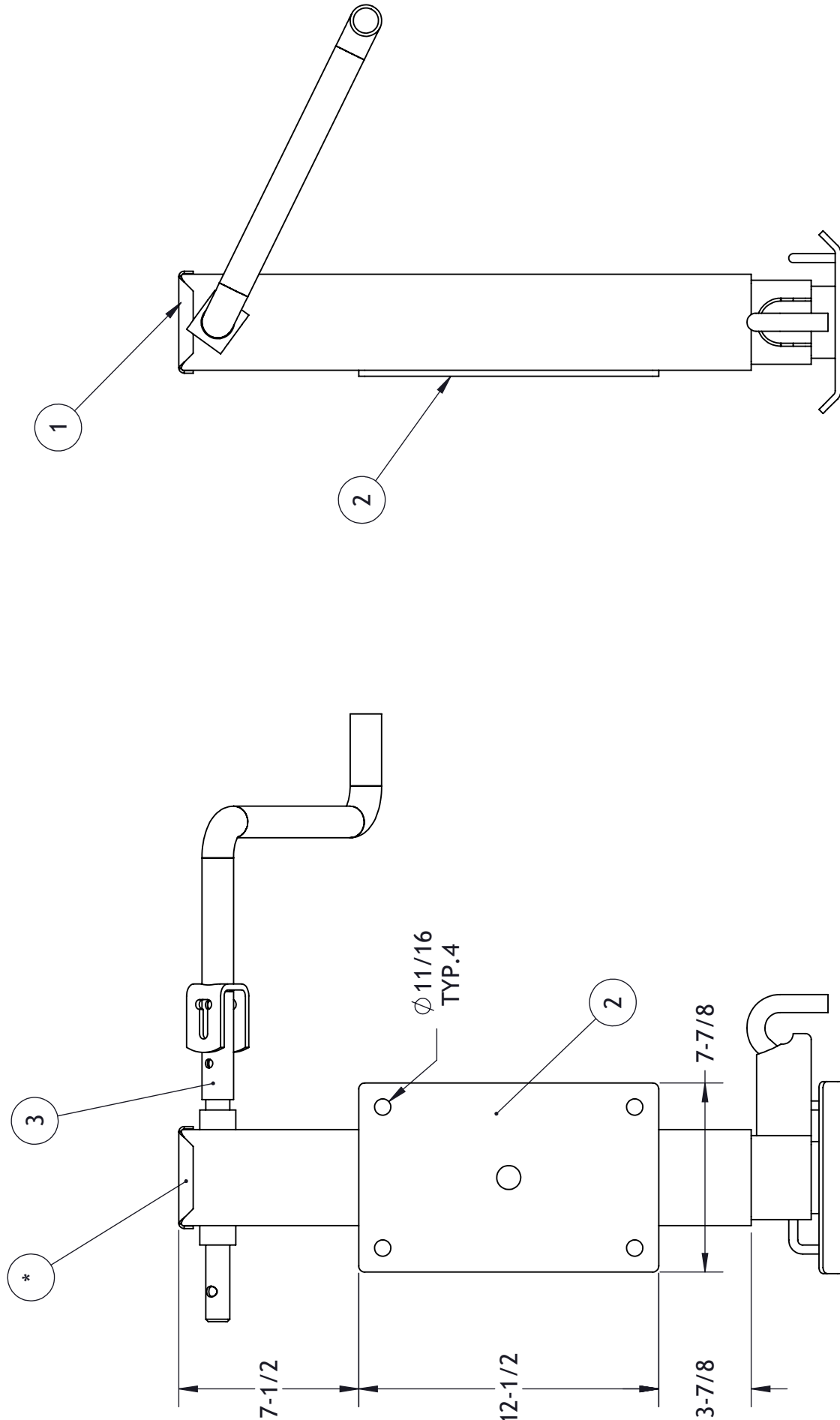
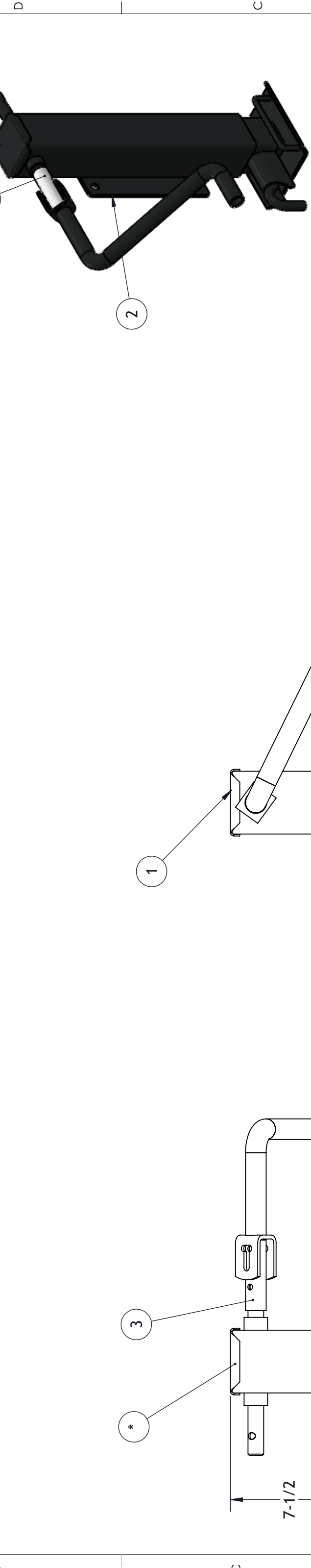

UNLESS OTHERWISE SPECIFIED: PROPRIETARY AND CONFIDENTIAL THE INFORMATION CONTAINED IN THIS DRAWING IS THE SOLE PROPERTY OF ReelStrong, Inc. ANY REPRODUCTION IN PART OR AS A WHOLE WITHOUT THE WRITTEN PERMISSION OF ReelStrong, Inc. IS PROHIBITED.		DIMENSIONS ARE IN INCHES TOLERANCE LIMITS ANGULAR = ± 1.0° DECIMAL .X = ±0.060 DECIMAL .XX = ±0.010 DECIMAL .XXX = ±0.005	
FRONT JACK ASSEMBLY		DO NOT SCALE DRAWING	
MATERIAL: FINISH: APPROX WEIGHT: LBS DRAWN:		TITLE:	
DATE: 3/14/2018		CUSTOMER:	
SHEET 1 OF 1		DWG. NO. 5016-0000-FrontJack	
REV 1		1	



A B C D

ITEM NO.	Vendor	Vendor NO	Default/QTY.	PART NUMBER	DESCRIPTION	Material	Length	WIDTH	Thickness	STEP 1	STEP 2	STEP 3
1	Nuera	19-570-SP	1	5016-0012(Default_As Machined_)-1	12K Jack					Purchase		
2	Alro		1	SL20KT-0099	Mounting Plate, Front Jack	Sheet, 0.25	7.88	12.50	0.25	Plasma		

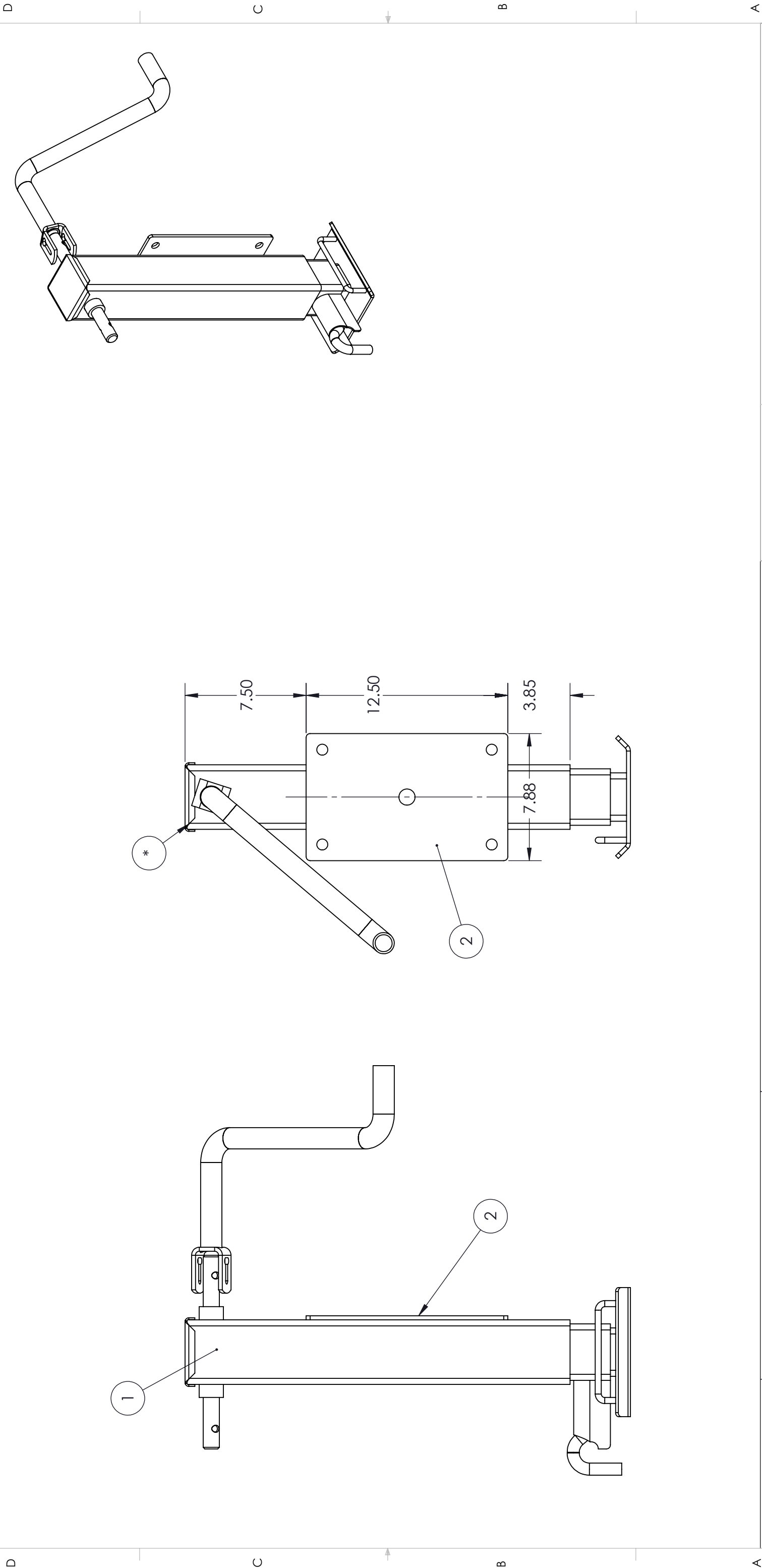

DO NOT SCALE DRAWING		UNLESS OTHERWISE SPECIFIED:		TITLE:	
PROPRIETARY AND CONFIDENTIAL		DIMENSIONS ARE IN INCHES		Rear Jack Assembly w. Plate	
THE INFORMATION CONTAINED IN THIS DRAWING IS THE SOLE PROPERTY OF ReelStrong, Inc. ANY REPRODUCTION IN PART OR AS A WHOLE WITHOUT THE WRITTEN PERMISSION OF ReelStrong, Inc. IS PROHIBITED.		TOLERANCE LIMITS		DATE 4/22/2016	
		ANGULAR = ± 1.0°		DWG. NO. 5016-0000-RearJack	
		DECIMAL .X = ±0.060		REV	
		DECIMAL .XX = ±0.010		SHEET 1 OF 1	
		DECIMAL .XXX = ±0.005		MATERIAL XXX	
		THIRD ANGLE PROJECTION		FINISH	
		THIRD ANGLE PROJECTION		WEIGHT LBS	
				CHK: -	
				DWN: -	





PROSPEC 2013

February 27, 2018
Version 8.6

Leaf Spring Axle

Prepared For: REELSTRONG 10KGD 88X64.5 EL Phone #:

FAX #:

Customer Part #:

E-Mail:

Customer Notes:

Prepared By: JUSTIN - NUERA TRANSPORT Phone #:800-626-2405

File Name: FAX #: 717-352-8017

E-Mail: JBERKEY@NUERA-TRANSPOR

Customer Selections

	<u>Model and Spindle</u>	<u>Combination</u>	<u>Hubface</u>	<u>Spring Center</u>	<u>Tube</u>		
Axle	D100GD Standard, Oil	Tandem	88.00	64.50	5.00 x LD		
	<u>PN</u>	<u>Type</u>	<u>Width</u>	<u>Length</u>	<u>Capacity</u>	<u>Description</u>	<u>Orientation</u>
Springs	072-080-01	Slipper	2.50	30	5000#/each	Rubber Bushed	Underslung
Hardware	<u>PN</u>	<u>Description</u>					
	HAP-258-01,	38.00" Spacing	QTY 1				
	HAP-158-00,	Single Hanger					
Brakes	<u>PN</u>	<u>Type</u>	<u>Size</u>	<u>Description</u>			
	K23-450-00 LH	Electric	12 1/4 x 3 3/8	Forward Self Adjust			
	K23-451-00 RH						
Hubs	<u>PN</u>	<u>Bolt Circle</u>	<u>Capacity</u>	<u>Description</u>			
	008-430-05	8 on 6.5	10000 #/pair	H-D, 5/8 Studs, Grs or Oil			
Wheels	<u>Size</u>	<u>Bolt Circle</u>	<u>Capacity</u>	<u>Wheel Offset</u>			
	17.5 x 6.75HC	8 on 6.5	4805 #/each	0.19 Inset			
Tires	<u>Size</u>	<u>Load Range</u>	<u>Capacity</u>	<u>Dual Capacity</u>			
	215/75R17.5H	H	4805 #/each	4540 #/each			
			@ 125 psi	@ 125 psi			

Calculated Capacity

Axle Capacity (each axle)	10,000 lbs	(Excluding rims, wheels and tires)
G.A.W.R. (each axle)	9,610 lbs	(Including rims, wheels and tires)
Entire Running Gear	19,220 lbs	(Including rims, wheels and tires)

Visit our website at www.dexteraxle.com

Copyright © 2013 by Dexter Axle Company. All rights reserved.

Page 1 of 4

Leaf Spring Axle

Prepared For:

REELSTRONG 10KGD 88X64.5 EL

Customer Part #:

File Name:

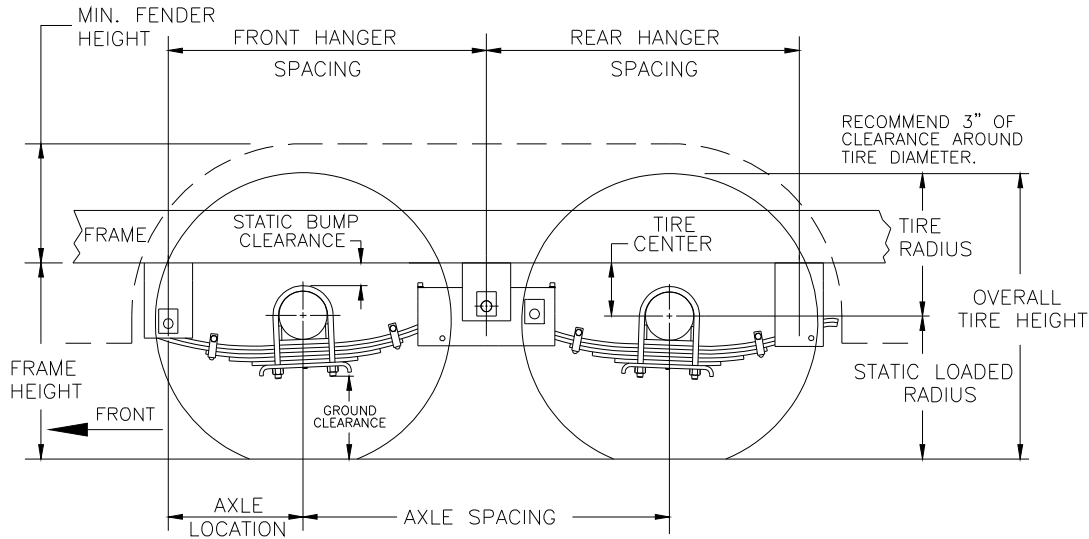

	Front	Center	Rear
Hanger Spacing	33.0	N/A	32.4
Axle Spacing	38.0	N/A	38.0
	Overall Ht	Radius	Static Loaded Radius
Tire Dimensions	29.3	15.3	14.0
Frame Height	18.8		
Min. Fender Height	13.5		
Axle Location	14.0		
Tire Center	4.8		
Static Bump Clearance	1.7		
Ground Clearance	7.6		

Unless Otherwise Specified All dimensions Are in Inches and shown at "Rated load" with trailer sitting "level".

If Static Bump Clearance is greater than 2.5", a bump stop should be used to avoid overstressing of leaf springs. Static Bump Clearance of less than 1.5" may limit full suspension movement and result in possible damage to the frame and/or axles when operating on some rough and uneven road surfaces. Tire clearance should always be greater than bump clearance to help prevent tire contact to underbody surfaces in the event of a suspension component failure.

Visit our website at www.dexteraxle.com

Copyright © 2013 by Dexter Axle Company. All rights reserved.

Page 2 of 4

Leaf Spring Axle

Prepared For:

REELSTRONG 10KGD 88X64.5 EL

Customer Part #:

File Name:

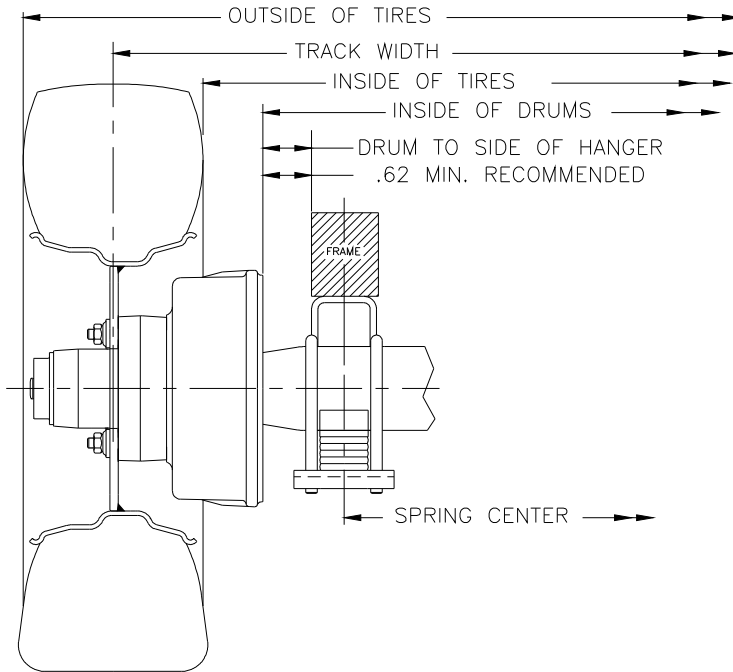

Hubface	Spring Center	Track Width
88.00	64.50	87.62
Outside of tires at the top		96.02
Inside of tires at the top		79.22
Tire to side of hanger		5.80
Inside of Brake		74.80
Brake to Hanger		3.59
Hub tip to hub tip		96.58

Unless Otherwise Specified All dimensions Are in Inches and shown at "Rated load"

Leaf Spring Axle

IMPORTANT

DISCLAIMER OF WARRANTY AND LIMITATION OF LIABILITY

All users of this ProSpec System (the "software") acknowledge that the information presented by the software is significantly affected by factors within the exclusive knowledge of the user including, among other things, service conditions, trailer configurations, load distributions, hitch and coupler arrangements and tow suspension characteristics, that the users have independently investigated these factors and have solely relied on those investigations when using the software, and that it is the responsibility of the user to adequately specify, evaluate and test its trailer/running gear combinations.

DEXTER AXLE DISCLAIMS ALL WARRANTIES, WHETHER WRITTEN, ORAL OR IMPLIED, IN FACT OR IN LAW (INCLUDING ANY WARRANTY OF MERCHANTABILITY OR FITNESS FOR A PARTICULAR PURPOSE), ASSOCIATED WITH THE USE OF THE SOFTWARE AND WITH ANY INFORMATION PRESENTED BY THE SOFTWARE.

Dexter Axle shall not be liable in damages (whether compensatory, punitive, direct, indirect, special, incidental or consequential) to any user of the software under contract, tort, strict liability or any other theory of liability, and any user agrees to indemnify and hold Dexter Axle harmless from any and all claims, actions or other proceedings (including attorney fees and court costs) arising out of the use of the software to the extent said claims, actions or other proceedings do not arise out of the sole and exclusive negligence of Dexter Axle.

LOAD RATINGS

The maximum load carrying capacity of any assembly is limited by the lowest load rating of any individual component selected. For instance, the load ratings of a pair of wheels may be lower than other axle components selected. If this is the case, the load carrying capacity of the axle assembly is reduced accordingly. As a specific example, if a pair of wheels is rated at 1500 pounds each and is used with other components rated at 4000 pounds per axle, the maximum load capacity is limited to 3000 pounds. If two tires are rated at 1400 pounds each and are used on this assembly, the maximum load carrying capacity is limited to 2800 pounds.

The following are trademarks of the Dexter Axle Company

Airflex[®]
Dexter[®]
E-Z Flex[®]
E-Z Lube[®]
Nev-R-Adjust[®]
Nev-R-Lube[®]
Torflex[®]