

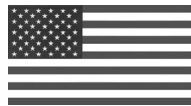

Standard Hi-CFM VacEXtreme

Operator's Manual



Made in the U.S.A.

Part Number: VACEX.OM
Revision: 5.2012

Introduction

This manual explains the proper operation and maintenance of your machine. Study and understand this manual thoroughly before operating or maintaining the machine. Failure to do so could result in serious personal injury, death, or equipment or property damage.

Consult with your Ring-O-Matic dealer or contact Ring-O-Matic if you do not fully understand the instructions in this manual; the controls or function of any machine component; or need additional information.

Instructions and specifications are based on the latest information available at time of publication. Your machine may have product improvements, options, custom fabrication, or features not published in this manual.

Right/Left sides of the machine are determined by facing the direction of forward travel.

Machine components are identified in "Section 3: Component Identification" on page 17. Photographs and illustrations are included for representation purposes only. Actual appearance may vary by model.

Two copies of this Operator's Manual are supplied with each machine. Always keep one copy of this manual inside the black storage box on the machine for ready reference. A separate Maintenance Manual is also supplied with the machine.

Additional copies of Ring-O-Matic manuals are available from your dealer or direct from Ring-O-Matic. Use the part number on the front cover when ordering additional copies.

No part of this manual may be reproduced in any form, or by any means electronic or mechanical, including photocopying, recording, or by any information storage and retrieval systems, without the express, written consent of Ring-O-Matic.

Ring-O-Matic reserves the right to make changes without notice or obligation.

Copyright 2012. All rights reserved.

Ring-O-Matic
P.O. Box 305 / 1714 Fifield Road
Pella, Iowa 50219
U.S.A.
800-544-2518 / 641-628-1515

Trademarks:

RING-O-MATIC, **RING-O-MATIC logo**, **CYCLO JET Pothole Excavator**, **VACEXTREME** are trademarks of Ring-O-Matic, Inc.

Printed in the U.S.A.

Table of Contents

Introduction	2
Section 1: Safety Messages	7
Section 2: Intended Use	15
Section 3: Component Identification	17
Control Panel (C)	17
Hydraulic Controls (H)	17
Vacuum System (V)	18
Water System (W)	20
Tools (T)	24
Section 4: Starting Procedure	27
Starting - Normal Conditions (Above Freezing)	27
Starting - Machine Preparation	27
Starting the Engine	27
Starting - Freezing Conditions	28
Section 5: Shutdown Procedures	29
Shutdown - Normal Conditions (Above Freezing)	29
Shutdown - Freezing Conditions	30
Winterizing the Water System (Option)	30
Shutdown the Machine	31
Section 6: Transporting the Machine	33
Report Safety Defects	33
Tire and Load Information	34
Towing Vehicle Selection	35
Tongue Weight	35
Weights (GVWR, Dry Weight, Maximum Cargo Weight)	35
Transporting - Preparation	36
Machine Preparation	36
Storage - Tools and Hoses	37
Trailer Height Adjustment	37
Trailer/Towing Vehicle Engagement	38
Hitch Coupler Connections	38
Pintle Ring Connections	39
Trailer/Towing Vehicle Disengagement	40
Hitch Coupler Separation	40
Pintle Ring Separation	41

Section 7: Preparation	43
Preparation - Operator	43
Operator - Qualifications	43
Operator - Training	43
Operator - Personal Protective Equipment	44
Preparation - Worksite	44
Worksite - Assessment	44
Worksite - Locate Buried Utilities	45
Call Your One-Call System Before Beginning Work	45
Worksite - Evidence of Underground Utilities	46
Worksite - Utility Strike	46
Electric Strike	46
Gas Strike	46
Fiber Optic Strike (Broken Line)	46
Preparation - Machine	47
Machine - Location	47
Machine - Inspection, Maintenance, and Initial Settings	47
Machine Inspection	47
Daily Maintenance	47
Initial Operational Settings	47
Section 8: Operating the Machine	49
Pre-Operation Information and Precautions	49
Preparation - Operator, Worksite, and Machine	49
Daily Inspection and Maintenance	49
Freezing Conditions	49
Low Water Level Automatic Shutoff	49
Blower Protection	50
Primary Blower Protection - Primary Shutoff	50
Secondary Blower Protection - Bag House	50
Operational Settings - Initial	51
Operation - Water Only (High-Pressure)	52
Operation - Vacuum Only	53
Operation - Excavating (Water and Vacuum)	54
Dump Collection Tank - Rear Door Fully Open	56
Dump Collection Tank - Pressurized Unloading	58
Collection Tank - Clean Interior	60
Back-Pressure Cleaning	62
Bag House Filters - Back-Pressure Cleaning	62
Vacuum Hose - Back-Pressure Cleaning	62
Vacuum Hose - Wash Interior	63

Section 9: Daily Maintenance 65

- General Maintenance Information 66
 - High-Pressure Water 66
 - Hourmeter 66
 - Inspection 66
 - Lubricants 66
 - Maintenance Service Intervals and Procedures 66
 - Modifications 66
 - Photos and Illustrations 67
 - Safety Shields 67
 - Severe Application 67
 - Specifications 67
 - Storage and Start-Up Procedures 67
 - Troubleshooting 67
 - Winterizing the Water System 67
- Maintenance 68
 - Daily Engine Maintenance Chart 69
 - Daily Machine Maintenance Chart 69
 - Daily Inspection 70
 - Trailer Break-Away System Battery and Cable - Check Each Trip 71
 - Break-Away System Cable - Inspect 71
 - Break-Away System Battery - Test 71
 - Break-Away System Battery - Charge 71
 - Tire Pressure and Lug Nuts - Check Daily 72

Section 10: Warranty 73

- New Industrial Equipment Limited Warranty 73
- Warranty Terms 73
- Retail Purchaser Responsibility 73
- Parts Warranty 76
- Exclusions of Warranties 76

Section 11: Receiving and Delivery 77

- Dealer Preparation 77
 - Engine 77
 - Hydraulics 77
 - General 77
- Delivery to Customer 78
 - Review of Operation 78
 - Dealer Information 79
 - Original Owner Information 79
- Identification Numbers - Record 80

Machine Serial Number	80
Engine Serial Number	80
Section 12: Specifications81
Lubricants	81
Machine Specifications	82
Specifications: 275 VacEx	83
Tires	83
Tongue Weight	83
GVWR; Dry Weight; Maximum Cargo Weight	83
Tank Capacities	83
Specifications: 550 VacEx	84
Tires	84
Tongue Weight	84
GVWR; Dry Weight; Maximum Cargo Weight	84
Tank Capacities	84
Specifications: 850 VacEx	85
Tires	85
Tongue Weight	85
GVWR; Dry Weight; Maximum Cargo Weight	85
Tank Capacities	85
Specifications: 1300 VacEx	86
Tires	86
Tongue Weight	86
GVWR; Dry Weight; Maximum Cargo Weight	86
Tank Capacities	86
Specifications: 2000 VacEx (Skid Mount Only)	87
GVWR; Dry Weight; Maximum Cargo Weight	87
Tank Capacities	87
Antifreeze Dilution Chart	88
Spoil Density Chart	88
Index89

Section 1: Safety Messages

IMPORTANT: Read and understand all Safety Messages.

IMPORTANT: See updated safety messages at: www.ring-o-matic.com.



	<p><i>This safety alert symbol indicates important safety messages within this manual and on machine safety decals. When you see this symbol, carefully read and understand the corresponding message and be alert to the possibility of serious personal injury or death.</i></p>
---	--

Safety messages within this manual and safety decals located on the machine use the signal words: “danger”, “warning”, and “caution”.



DANGER: Indicates imminent hazards which, if not avoided, will result in serious personal injury or death.

WARNING: Indicates a potentially hazardous situation which, if not avoided, could result in a serious personal injury or death.

CAUTION: Indicates potentially hazardous situations or unsafe practices which, if not avoided, could result in serious personal injury or in product or property damage.

 WARNING	<p>Read this manual, all safety messages, and all machine decals before operating or maintaining this machine.</p>
	

 WARNING	<p>Only allow authorized and properly trained personnel to inspect, operate, and perform maintenance on this machine.</p>
	<p>DO NOT allow machine to run unattended.</p>

 WARNING	<p>Inspect machine before operating. Machine must be in good operating condition with all safety shields and components installed and functioning properly.</p>
	

	<p>Wear personal protective equipment. Dress properly. See "Operator - Personal Protective Equipment" on page 44.</p>
---	---

	<p>DO NOT excavate or vacuum chemicals or flammable, hazardous, or toxic materials.</p>
---	---

	<p>A damaged electrical cable can cause electric shock and result in serious injury or death.</p> <p>A ruptured gas line can cause an explosion and/or fire resulting in serious injury or death.</p> <p>Laser light from a cut fiber optic line can result in eye damage.</p> <p>Locate utilities before digging. Call 811 (U.S.A. only) or 1-888-258-0808 (U.S. or Canada), local utility companies, or national regulating authority.</p>
---	--

	<p>Use the Shutdown Procedure before servicing, cleaning, repairing, refueling, or transporting the machine. See "Section 5: Shutdown Procedures" on page 29. A variation of this procedure can be used if instructed to do so in this manual or if an emergency requires it.</p>
--	---

	<p>Fuel and fumes can explode and burn, resulting in serious injury or death.</p> <p>Shutdown engine before refueling. Extinguish flames and DO NOT smoke. Take precautions to eliminate static discharges.</p>
---	---

	<p>DO NOT use fluid or aerosol starting aids such as ether, which can result in an explosion causing serious injury or death.</p>
---	---

⚠ DANGER!

DO NOT operate machine with pressure (option) in collection tank greater than 4.5 psi (0.31 bar). Collection tank can explode, resulting in serious injury or death. DO NOT adjust Collection Tank Pressure Relief.

⚠ DANGER!



A pressurized collection tank (if equipped) can cause serious injury or death.

If collection tank is pressurized, bag house lid or primary shutoff lid can blow off by loosening wing nuts. Also, spoil can be ejected rapidly from bag house drain valve or tank suction valve if opened under pressure.

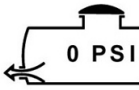

Relieve collection tank pressure *before* opening lids by setting the pressure/vacuum selector lever (if equipped) to neutral and opening the bag house drain valve and collection tank suction valve.

⚠ CAUTION

Spoil can be ejected rapidly from collection tank during pressurized unloading (if equipped), resulting in serious injury or property damage. Stay clear of dump valve.

⚠ DANGER!



Vacuum can suffocate or damage vision or hearing.

Keep vacuum hose end away from face and ears.

⚠ CAUTION

DO NOT operate machine with vacuum in collection tank greater than 14" Hg (47 kPa). Blower damage will occur.

⚠ WARNING



Electrical shock can result in serious injury or death.

Pressurized water from any high-pressure water tool can damage electrical cables. The water tool will conduct electricity. Contact with damaged electrical cables can result in electrical shock.



Wear electrically insulated gloves and boots. DO NOT allow any part of your body to come into contact with the digging tool except for your insulated-gloved hands.

! WARNING

Improper operation can result in serious injury or death or damage to the machine. **DO NOT** raise collection tank while it is under vacuum or with rear door closed.

! WARNING



Hydraulic or mechanical failure can cause a raised rear door to fall, which can result in serious injury or death. **DO NOT** work under an opened door until the door is securely supported in the raised position.

! WARNING



Hydraulic or mechanical failure can cause a raised collection tank to fall, which can result in serious injury or death. **DO NOT** work under a raised collection tank until the tank is securely supported in the raised position.

! WARNING



Confined space can cause suffocation. Use proper confined space procedures before entering collection tank or **STAY OUT**. Ensure door is securely supported in the raised position before entering tank.

! WARNING

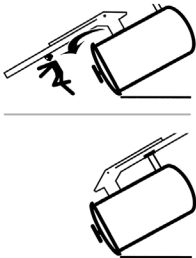

Unsecured boom (if equipped) can swing and cause serious injury or death.

Secure boom in transport position before raising tank or moving machine.

! CAUTION

Dispose of antifreeze in accordance with Local, State, and Federal Regulations.

Dump spoil only in accordance with Local, State, and Federal Regulations. Special permit(s) or license(s) may be required.

! WARNING



Keep spectators away from machine and work site.

! WARNING

When operating near a street or road, take measures to warn and divert motor and pedestrian traffic. Use all necessary cones, flag persons, lighting devices, or signs necessary for the work situation.

! WARNING

Clear pathway and warn others to stay away before backing. Serious injury or death could result if a person is struck or run over by the machine. Use a spotter to direct driver when moving the machine.

! WARNING

Reduced or loss of steering or braking can result in serious injury or death. Use only transport or towing vehicles rated for the load being towed.

! WARNING

Safety towing chains help control machine if accidental separation from towing vehicle occurs. Chains, hooks, and hook latches must not be damaged or missing. **DO NOT** tow machine unless towing chains are used.

! WARNING

Sudden machine movement can result in serious injury or death. Machine weight can cause ground to give way.

Machine can roll downhill or roll over or fall into excavation. Park or position machine only on stable, level surfaces, well away from edges of embankments or areas of excavation.

Securely chock tires before detaching machine from towing vehicle.

! WARNING

Perform Daily Inspection and Daily Maintenance before operating the machine. Complete all necessary adjustments and repairs before operating the machine.

Only allow authorized and properly trained personnel to inspect, operate, and perform maintenance on this machine.

! WARNING



Entanglement with power driven parts can result in serious injury or death. Keep hands, feet, clothing, and hair, away from power driven parts. Keep shields in place and properly secured.

! WARNING



Pinch points can result in serious crushing injuries. Keep hands and feet away from all pinch points.

! WARNING



Engine exhaust can asphyxiate. Operate machine outdoors. Whenever the engine must be run in an enclosed environment, take all necessary precautions to ensure an adequate supply of fresh air. Use a suitable hose or pipe to vent exhaust fumes outdoors. Use an approved respirator as needed to protect respiratory tract.

! WARNING



Hot fluid under pressure can scald.

Allow engine to cool before opening radiator cap (if equipped).

! DANGER

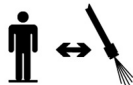

Avoid high-pressure water. Pressurized water from any water tool can penetrate body tissue and result in serious injury or death. **DO NOT** point any high-pressure water tool at yourself or any other person.

Wear appropriate eye protection. Keep nozzles away from the body. **DO NOT** use pressurized water to clean body parts or clothing. Water injected under the skin must be removed immediately by a surgeon familiar with this type of injury.

! CAUTION

Power washing can damage or destroy electronic seals or components. **DO NOT** allow pressurized water to come into contact with electronic components.

! WARNING



Pressurized hydraulic fluid can penetrate body tissue and result in serious injury or death. Leaks can be invisible. Keep away from suspected leaks. Relieve pressure in the hydraulic system before searching for leaks, disconnecting hoses, or before performing any other work on the system.

If you must pressurize the system to find a leak, use an object such as a block of wood or a piece of cardboard held next to the suspected leak location, rather than using your hands. When loosening a fitting where residual pressure may exist, slowly loosen the fitting until fluid begins to leak. Wait for leaking to stop before disconnecting the fitting.

Fluid injected under the skin must be removed immediately by a surgeon familiar with this type of injury.

! WARNING

A raised trailer frame can fall and result in serious injury or death. Work only on a level surface and support raised trailer frame, axle, and suspension system with suitable blocking

! WARNING



Exploding tire can cause serious injury or death. To help prevent tire explosion:

Maintain proper tire pressure. Inflating a tire above or below the recommended pressure can cause tire damage.

Replace any tire with cuts or bubbles. Replace tires before excessive wear occurs. Replace any damaged rims.

DO NOT weld or heat wheel assembly. Heating increases tire pressure.

! WARNING



Battery fumes are flammable and can explode resulting in serious injury or death. Battery explosion and acid can blind or burn. Keep all burning materials away from battery. Tools and cable clamps can make sparks.

Read instructions. DO NOT smoke. Shield eyes and face.

! WARNING

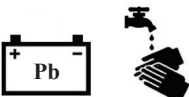

Battery post terminals and related accessories contain lead and lead compounds, which are known to the state of California to cause cancer and reproductive harm.

Wash hands after handling.

 **WARNING**

Vacuum Relief and Water Pressure have been pre-set at the factory. DO NOT exceed factory settings. Serious injury or death can result from improper settings.

Refer to the Maintenance Manual for more information and procedures on these systems.

 **DANGER**

Collection Tank Pressure Relief has been pre-set at the factory. DO NOT adjust Collection Tank Pressure Relief. Serious injury or death can result from improper settings.

 **WARNING**

Failure to follow any of the preceding safety messages; safety information or instructions following in this manual; or safety decals on the machine could result in serious injury or death.

This machine is to be used only for the purposes for which it is intended, as explained in this manual.

Section 2: Intended Use

The Standard, Hi-CFM, and VacEXtreme machines are intended to be used as a fluid-assisted excavating (potholing) machine or as a vacuum-assisted material cleanup machine.

The machine is designed to excavate or clean-up soil cuttings, drilling fluids, small solid debris, and other non-toxic/non-hazardous waste. Do Not excavate or vacuum chemicals or flammable, hazardous, or toxic materials.

Always use the machine in accordance with the instructions and safety messages contained in this manual, safety signs on the machine, and any other materials provided by Ring-O-Matic.

Daily inspections, proper maintenance, and repair are essential for safe and efficient machine operation. Do Not use the machine if it is not operating properly or needs repair.

Only allow responsible, properly trained, and authorized personnel to inspect, operate, and perform maintenance on the machine.

End of Section.

This page intentionally left blank.

Section 3: Component Identification

IMPORTANT: Read and understand all Safety Messages. See "Section 1: Safety Messages" on page 7.

Control Panel (C)

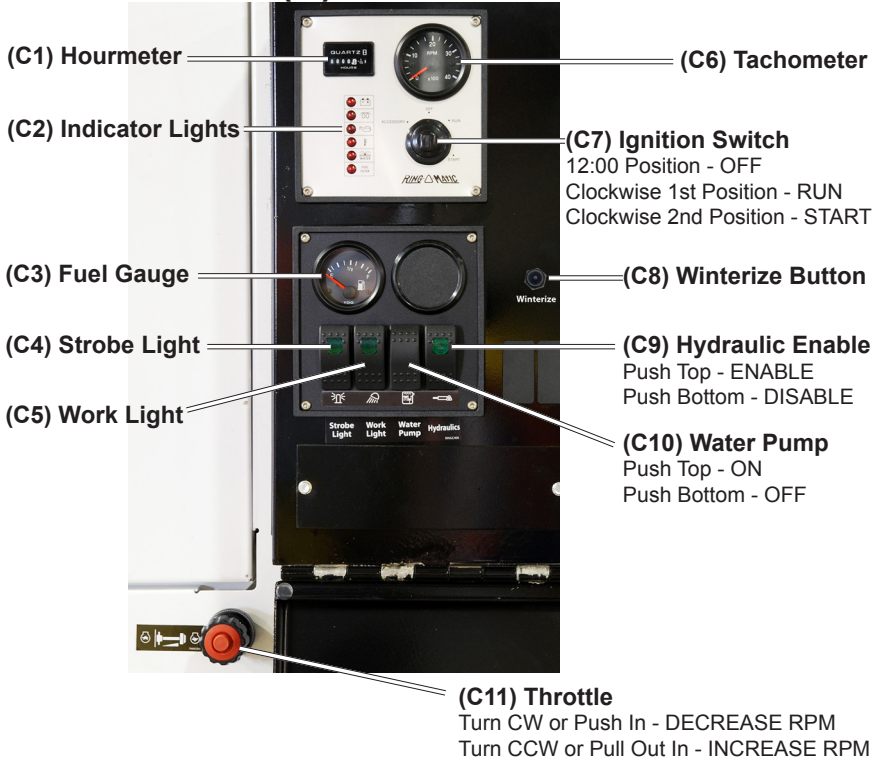

Hydraulic Controls (H)

(H1) Collection Tank Raise/Lower
Push Top - RAISE TANK
Push Bottom - LOWER TANK

(H2) Rear Door Raise/Lower
Push Top - RAISE DOOR
Push Bottom - LOWER DOOR

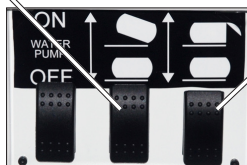

NOTE: Hydraulic controls may be located on either side of the machine.

Vacuum System (V)

(V1) Suction Valve

(V2) Rear Door Latch Lever

(V3) Dump Valve



(V4) Blower & Vacuum Relief Valve

(V5) Pressure/Vacuum Gauge



(V6) Pressure/Vacuum (4-Way) Valve Lever (option)

Up (45° Angle) - PRESSURE
Middle (Horizontal) - NEUTRAL
Down (45° Angle) - VACUUM

Press Button - UNLOCKS LEVER
Release Button - LOCKS LEVER



(V7) Primary Shutoff Assembly
(Collection Tank Interior)

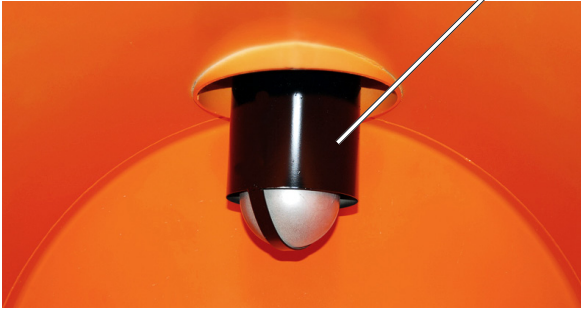

(V8) Bag House Lid

(V9) Primary Shutoff Lid



(V10) Bag House Drain Valve

Lever 90° to Valve - CLOSED
Lever Parallel to Valve - OPEN

(V11) Collection Tank Pressure Relief Valve (option)



Water System (W)

(W1) Water Pump Switch
(Two Locations / Identical Function)
Push Top - ON
Push Bottom - OFF



Control Panel

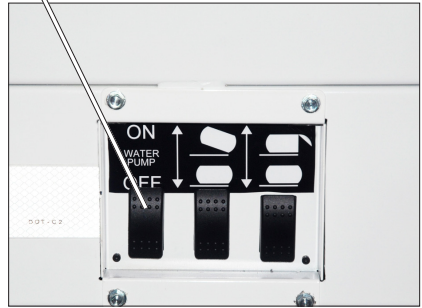

Toward Rear of Machine

(W2) Water Pump

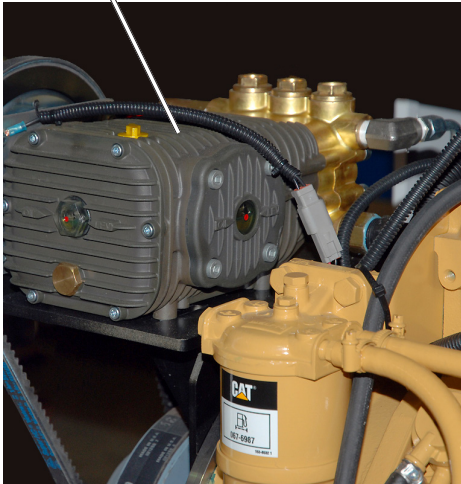

(W3) Water Pressure Gauge & Unloader Valve

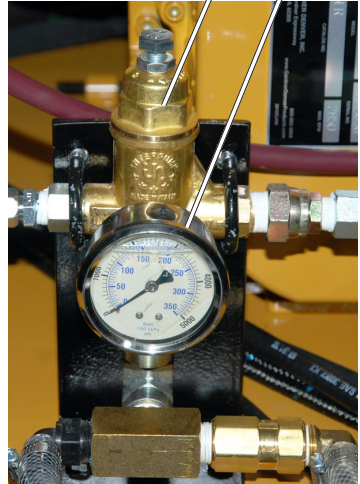

(W4) Hose Reel Crank
(Transport Position)

(W5) Hose Reel Tension Adjustment Knob
Counter Clockwise - FREEWHEELING
Fully Clockwise - LOCKED



(W6) Hose Storage Fitting

(W7) Water Strainer

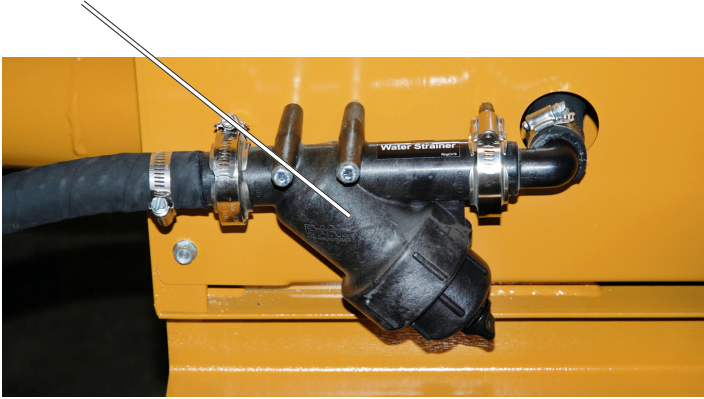

(W8) Water Tank Drain Valve Lever

Lever 90° to Valve - CLOSED
Lever Parallel to Valve - OPEN





(W9) Winterize Button (Option)



(W10) Antifreeze Tank (Option)

(W11) Fluid Selector Valve

Not shown.
(Located below the Antifreeze Tank)
Configuration Varies by Model

Tools (T)

(T1) Trailer Tool Storage

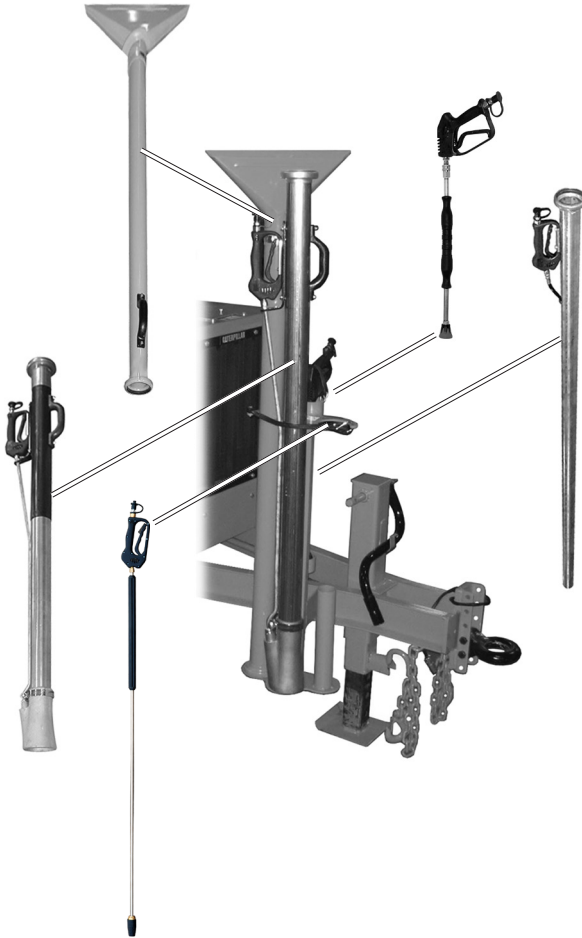

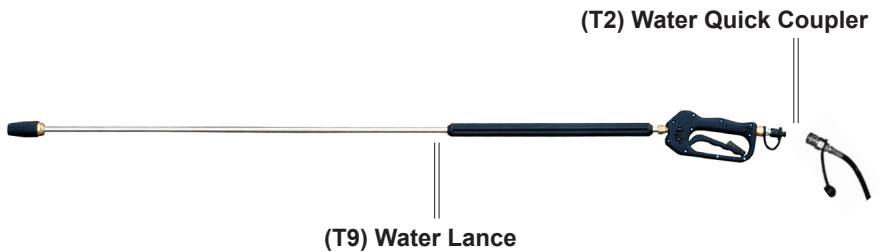
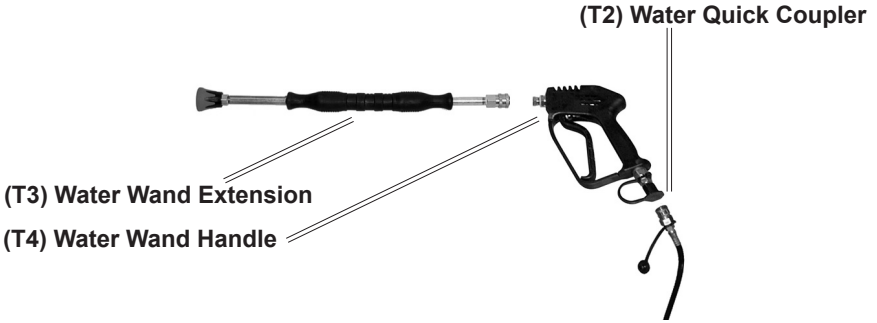

End of Section.

This page intentionally left blank.

Section 4: Starting Procedure

IMPORTANT: Read and understand all Safety Messages. See "Section 1: Safety Messages" on page 7.

NOTE: See "Section 3: Component Identification" on page 17.

Normal Conditions: See below.

Freezing Conditions: See "Starting - Freezing Conditions" on page 28.

Starting - Normal Conditions (Above Freezing)

Starting - Machine Preparation

1: Check engine and machine fluid levels. Perform daily inspection and daily maintenance. See "Section 9: Daily Maintenance" on page 65.

2: Configure machine as follows:

- Water Pump Switch (W1)*OFF
- Suction Valve (V1)*..... CLOSED
- Dump Valve (V3)*..... CLOSED
- Rear Door Lever (V2)*..... LATCHED
- Bag House Drain Valve (V10)* OPEN
- Pressure/Vacuum Selector Lever (V6)* (if equipped). . . . NEUTRAL

Starting the Engine

1: Set *throttle (C11)* to LOW idle.

2: Turn *ignition switch (C7)* to RUN.

3: Wait for *glow-plug indicator light (C2)* to go OFF.

4: Turn *ignition switch* to START and release when engine starts.

NOTE: Do Not crank engine for more than 15 seconds. Allow starting motor to cool for two minutes between starting attempts.

5: After engine is idling smoothly, gradually increase *throttle* to HIGH (FULL).

Starting - Freezing Conditions

NOTE: See the Engine Operation Manual, shipped with the machine, for cold weather information including oil and fuel requirements.

NOTE: Ensure machine water system antifreeze tank is full.

- 1:** Follow "Starting - Normal Conditions (Above Freezing)" on page 27.
- 2:** Allow engine to warm up at LOW idle *with no load for 10 minutes*.
- 3:** Slowly increase *throttle (C11)* to HIGH (FULL).
- 4:** Operate machine at low-load until all systems reach operating temperatures.

Section 5: Shutdown Procedures

IMPORTANT: Read and understand all Safety Messages. See "Section 1: Safety Messages" on page 7.

NOTE: See "Section 3: Component Identification" on page 17.

Normal Conditions (Above Freezing): See below.

Freezing Conditions: See "Shutdown - Freezing Conditions" on page 30.

Shutdown - Normal Conditions (Above Freezing)

- 1:** Empty the collection tank and clean machine. See "Dump Collection Tank - Rear Door Fully Open" on page 56 or "Dump Collection Tank - Pressurized Unloading" on page 58.
- 2:** Set *water pump switch (W1)* OFF.
- 3:** Squeeze water wand trigger to relieve residual water pressure in hose.
- 4:** Roll water hose onto hose reel and connect hose end to storage fitting.
- 5:** Tighten *water hose reel tension adjustment knob (W5)*.
- 6:** OPEN *bag house drain valve (V10)*.
- 7:** CLOSE *suction valve (V1)* and *dump valve (V10)*.
- 8:** Set *pressure/vacuum selector lever (V6)* (if equipped) to NEUTRAL.
- 9:** Set throttle (**C11**) to LOW idle and allow blower and engine to cool down for **5-10 minutes**.
- 10:** Turn *ignition switch (C7)* OFF.
- 11:** CLOSE *bag house drain valve* (to prevent mice and other small animals from entering bag house and ruining filters).
- 12:** Store hoses and tools. See "Tools (T)" on page 24.

Shutdown - Freezing Conditions

NOTE: Freezing water expands and can damage water system components, voiding warranties.

NOTE: Dispose of antifreeze in accordance with Local, State, and Federal regulations.

Winterizing the Water System (Option)

Winterization procedures are also stated on a decal inside the control panel.

- 1: Ensure machine is level or water tank(s) may not empty completely.
- 2: Fill *antifreeze tank (W10)* as needed.

NOTE: Follow the antifreeze manufacturer's dilution recommendations. Approximate residual water left in the system with *empty* water tank(s):

- Machines with a 50 ft (15 m) water hose 3 qt (3 L)
- Machines with a 100 ft (30 m) water hose 6 qt (6 L)

- 3: Check concentration in the water system antifreeze tank to ensure the mixture will not freeze. See the "Antifreeze Dilution Chart" on page 88.
- 4: Empty the collection tank and clean machine. See "Dump Collection Tank - Rear Door Fully Open" on page 56 or "Dump Collection Tank - Pressurized Unloading" on page 58.
- 5: Turn *water pump switch (W1)* OFF.
- 6: Squeeze water wand trigger to relieve residual water pressure in hose.
- 7: OPEN *water tank drain valve (W8)* and drain water tank(s) completely. CLOSE valve.
- 8: Roll water hose onto hose reel and connect hose end to storage fitting.

NOTE: Hose end must be connected to storage fitting for antifreeze mixture to flow through the water system.

- 9: Set *fluid selector valve* to **(W11)** ANTIFREEZE.
- 10: Start engine. See "Section 4: Starting Procedure" on page 27.
- 11: Set *water pump switch* to ON.

- 12:** Press (and hold) the *winterize button (C8)* to circulate antifreeze mixture throughout the water system.
- 13:** Release the *winterize button* when green antifreeze solution is visible and circulating through both clear water lines.
- 14:** Set *water pump switch* to OFF.

Shutdown the Machine

- 15:** Tighten *water hose reel tension adjustment knob (W5)*.
- 16:** OPEN *bag house drain valve (V10)*.
- 17:** CLOSE *suction valve (V1)* and *dump valve (V3)*.
- 18:** Set *pressure/vacuum selector lever (V6)* (if equipped) to VACUUM.
- 19:** Set *throttle (C11)* to LOW idle (factory setting) and allow blower and engine to cool down for **5-10 minutes**.
- 20:** Turn *ignition switch (C7)* OFF.
- 21:** CLOSE *bag house drain valve* (to prevent mice and other small animals from entering bag house and ruining filters).
- 22:** Store hoses and tools on machine. See "Tools (T)" on page 24.

End of Section.

This page intentionally left blank.

Section 6: Transporting the Machine

IMPORTANT: Read and understand all Safety Messages. See "Section 1: Safety Messages" on page 7.

NOTE: See "Section 3: Component Identification" on page 17.

Towing vehicle must be rated to tow or transport machine. See "Towing Vehicle Selection" on page 35.

Always prepare machine for transport. See "Transporting - Preparation" on page 36.

Obey all applicable laws regarding use of lights, safety chains, and all other requirements concerning road use.

Use good judgment and drive carefully.

Report Safety Defects

IMPORTANT: Do Not start the engine or transport the machine if you believe it has a defect which could cause an accident, injury, or death. Inform your supervisor about the issue(s) immediately. Also contact the National Highway Traffic Safety Administration (NHTSA) and notify Ring-O-Matic as soon as possible.

Should NHTSA receive similar complaints, an investigation may be opened. If safety defects exist in a group of machines, NHTSA may order a recall and remedy campaign. However, NHTSA cannot become involved in individual difficulties between you, your dealer, or Ring-O-Matic.

How to contact NHTSA regarding concerns about your machine:

- Call the DOT Auto Safety Hotline at 1-888-327-4236. The Hotline also can supply general information about motor vehicle safety.
- File a report on-line at www.nhtsa.dot.gov/hotline/.
- Write to NHTSA, U.S. Department of Transportation, 400 7th Street SW, Washington, D.C. 20590

Tire and Load Information

Also see "Machine Specifications" on page 82.

The weight of cargo should never exceed _____ kg or _____ lbs

TIRE	SIZE	COLD TIRE PRESSURE
FRONT		
REAR		
SPARE		

SEE OWNER'S MANUAL FOR ADDITIONAL INFORMATION

Trailers with a GVWR of 10,000 pounds or less have a Tire and Loading Information placard, similar to the one shown above. This placard is located near the V.I.N. plate and states:

- Maximum Cargo (spoil and water) Weight
- Tire Size
- Cold Tire Pressure Recommendation

See "Machine Specifications" on page 82 for weights (GVWR; Machine Dry Weight; and Maximum Cargo Weight).

IMPORTANT: Do Not exceed GVWR (Gross Vehicle Weight Rating).

NOTE: For detailed tire information, go to the National Highway Traffic Safety Administration (NHTSA) web site and search for "Tire Safety Information."

Towing Vehicle Selection

IMPORTANT: Machine weight and tongue weight vary greatly with the:

- 1) Water tank level.
- 2) Collection tank level.
- 3) Type of spoil in the collection tank.

Towing vehicle must be equipped with the following:

- Sufficient suspension capacity to resist downward loads at the hitch during transportation.
- A vehicle and hitch rated for the machine's GVWR.
- A vehicle and hitch rated for the machine's wet tongue weight.
- An electric brake controller that automatically applies the towed machine's electric brakes when stopping.
- Mud flaps to deflect flying debris from the tires.

Tongue Weight

See "Machine Specifications" on page 82.

Weights (GVWR, Dry Weight, Maximum Cargo Weight)

See "Machine Specifications" on page 82.

IMPORTANT: Spoil types range in density from approximately 9 lb/gallon (1.1 kg/L) to over 17 lb/gallon (2 kg/L). See "Spoil Density Chart" on page 88.

Transporting - Preparation

NOTE: When the collection tank is full or nearly full, drain the water tank before transporting the machine to reduce gross weight.

Machine Preparation

- 1:** CLOSE and LATCH (**V2**) collection tank rear door.
- 2:** CLOSE bag house lid (**V8**) and primary shutoff lid (**V9**). Hand tighten wing nuts.
- 3:** CLOSE suction valve (**V1**), and dump valve (**V3**), and bag house drain valve (**V10**).
- 4:** The following must be in good condition and function properly:
 - Highway lights
 - Trailer Break-Away System (check cable and battery charge)
 - Safety towing chain and hook; and trailer brakes

Storage - Tools and Hoses

Roll water hose onto reel and connect to hose-end storage fitting **(W6)**. Tighten hose reel tension adjustment knob **(W5)** to prevent hose from unwinding.

Store and secure tools (including hose reel crank on some models) and vacuum hose(s) on towing vehicle or trailer **(T1)**.

NOTE: Secure tools and hoses in storage position with straps or ties to prevent them from causing a traffic hazard.

Trailer Height Adjustment

Ensure machine is level during transport for optimum tongue weight on towing vehicle.

- 1:** Remove trailer hitch coupler or pintle ring mounting bolts and adjust trailer height to match the towing vehicle's ball hitch or pintle ring hook height.

NOTE: Ensure lock nuts or lock washers are used.

- 2:** Install and torque all bolts to 120 ft-lb (165 Nm).

Trailer/Towing Vehicle Engagement

Hitch Coupler Connections

NOTE: Do Not use the brake-away system as a park-brake.

NOTE: Ensure hook latches are present and function properly.

- 1:** Open hitch coupler.
 - 2:** Back vehicle into position.
 - 3:** Use jack handle to lower hitch coupler onto hitch ball.
 - 4:** Close hitch coupler and install keeper pin.
 - 5:** Cross towing chains under tongue and attach to towing vehicle. Ensure hook latches function properly.
 - 6:** Attach break-away cable to towing vehicle bumper or frame. Adjust cable length so Break-Away System will apply brakes only after towing chains are detached.
 - 7:** Connect highway lights/electric brake connector to towing vehicle.
- IMPORTANT:** Ensure highway lights and trailer brakes and are in good condition operate properly.
- 8:** Turn jack handle to transfer trailer weight to towing vehicle.
 - 9:** Pull foot keeper-pin, raise foot-slide, and install pin in bottom hole of the foot-slide.
 - 10:** Remove wheel chocks before moving trailer.

Pintle Ring Connections

NOTE: Do Not use the brake-away system as a park-brake.

NOTE: Ensure hook latches are present and function properly.

- 1:** Open pintle hook.
 - 2:** Back vehicle into position.
 - 3:** Close and lock pintle hook and install keeper pin.
 - 4:** Cross towing chains under tongue and attach to towing vehicle. Ensure hook latches function properly.
 - 5:** Attach break-away cable to towing vehicle bumper or frame. Adjust cable length so Break-Away System will apply brakes only after towing chains are detached.
 - 6:** Connect highway lights/electric brake connector to towing vehicle.
- IMPORTANT:** Ensure highway lights and trailer brakes function properly.
- 7:** Turn jack handle to transfer trailer weight to towing vehicle.
 - 8:** Pull foot keeper-pin, raise foot-slide, and install pin in bottom hole of the foot-slide.
 - 9:** Remove wheel chocks before moving trailer.

Trailer/Towing Vehicle Disengagement

Hitch Coupler Separation

NOTE: Do Not use the brake-away system as a park-brake.

- 1:** Park machine on a stable, level surface.
- 2:** Chock trailer tires to prevent unwanted movement.
- 3:** Pull foot keeper-pin, lower foot-slide, and install foot-keeper pin in appropriate foot-slide hole.
- 4:** Turn jack-handle to raise tongue and remove trailer weight from towing vehicle.
- 5:** Detach highway lights/electric brake connector, break-away cable, and safety towing chains from towing vehicle. Secure components on the trailer tongue.
- 6:** Open hitch coupler.
- 7:** Turn jack handle to raise trailer tongue until hitch coupler clears hitch ball.
- 8:** Move towing vehicle forward.

Pintle Ring Separation

NOTE: Do Not use the brake-away system as a park-brake.

- 1:** Park machine on a stable, level surface.
- 2:** Chock trailer tires to prevent unwanted movement.
- 3:** Pull foot keeper-pin, lower foot-slide, and install foot-keeper pin in appropriate foot-slide hole.
- 4:** Turn jack-handle to raise tongue and remove trailer weight from towing vehicle.
- 5:** Detach highway lights/electric brake connector, break-away cable, and safety towing chains from towing vehicle. Secure components on the trailer tongue.
- 6:** Open pintle hook.
- 7:** Turn jack handle to raise trailer tongue until the pintle ring clears the pintle hook.
- 8:** Move vehicle forward.

End of Section.

This page intentionally left blank.

Section 7: Preparation

IMPORTANT: Read and understand all Safety Messages. See "Section 1: Safety Messages" on page 7.

NOTE: See "Section 3: Component Identification" on page 17.

Preparation - Operator

Operator - Qualifications

An operator must have the mental and physical capabilities to operate the machine safely and must be familiar with all workplace safety rules and regulations.

A Commercial Drivers Licence (CDL) may be required to transport this machine. Contact the Department of Transportation (DOT) for more information.

Operator - Training

NOTE: The operator must become familiar with the controls, operation, and intended use of the machine under the supervision of a trained, experienced operator.

Before operating this machine at an actual worksite, the operator must be trained at a site free of underground utilities and cover:

- All sections of this manual.
- Safety messages in this manual and safety decals on the machine.
- Transporting the machine safely.
- Proper machine location and preparation.
- How to have underground utilities located, utility identification, and what to do in the event of each type of utility strike.

Operator - Personal Protective Equipment

Personal protective equipment must be worn while operating this machine. Wear the following:

- hard hat
- eye protection (wraparound safety glasses or goggles)
- safety vest (wear reflective clothing when working near traffic)
- adequate hearing protection
- safety shoes
- electrically insulated gloves and boots (when excavating/potholing)

IMPORTANT: Reduce the risk of being caught or entangled in moving components by wearing close-fitting clothing. Confine long hair and avoid wearing jewelry such as bracelets, necklaces, rings, or wristwatches.

NOTE: All workers, in the immediate area, must wear personal protective equipment and take identical precautions as listed above.

Preparation - Worksite

Worksite - Assessment

Understand and comply with all worksite rules and regulations.

Examine worksite for obstructions, conditions, or situations, which could impair machine operation or create a safety hazard. Use the information in this manual combined with your own good judgment to identify hazards and implement hazard avoidance measures.

When work is planned near structures (such as bridges, buildings, power lines, or tree limbs) check for adequate overhead and side clearances.

When operating near a street or road, take measures to warn and divert motor and pedestrian traffic. Use all necessary cones, flag persons, lighting devices, or signs necessary for the work situation.

Do Not operate machine in an area with flammable dust or vapors. Sparks from the machine's electrical system or engine exhaust can result in an explosion or fire in a flammable or explosive atmosphere.

Operate only outdoors. If indoor operation is essential, use an appropriate respirator, provide good ventilation, and direct exhaust fumes outdoors with a suitable hose. Carbon monoxide fumes from an engine can asphyxiate.

Keep spectators away from the machine.

Worksite - Locate Buried Utilities

Call Your One-Call System Before Beginning Work

Call the local One-Call system (and all utility companies that do not subscribe to the One-Call system) before beginning an excavation project. A One-Call representative will notify participating utility companies of your proposed excavation activities.

Call 811 (U.S.A. only) or 1-888-258-0808 (U.S.A. or Canada), local utility companies, or national regulating authority to locate and mark underground utility installations.

NOTE: Failure to call the One-Call system may result in serious injuries or death, accidents, interruption of services, damage to environment, work delays, or costly utility damages.

One-call participating utility companies mark their underground facilities by using the following color codes:

COLOR	UTILITY
Blue	Potable Water
Green/Brown	Sewer
Orange	Communications, Telephone, TV
Pink	Surveying
Red	Electric
White	Proposed Excavation
Yellow	Gas, Oil, Petroleum

NOTE: OSHA CFR 29 1926.651 requires estimated locations of underground utilities be determined before beginning excavations or underground drilling operations. When an actual excavation or bore approaches an estimated utility location, exact location of the underground installation must be determined by a safe, acceptable, and dependable method. *If a utility cannot be precisely located, it must be SHUT OFF by the utility company.*

Worksite - Evidence of Underground Utilities

Visually check for the following:

- Communications enclosures or structures
- Drop boxes
- Electrical enclosures or structures
- Manhole covers
- Recent excavation or trenching activity
- Underground utility placement notices

Worksite - Utility Strike

IMPORTANT: Machine operator(s) must be prepared what to do in the event of any type of utility strike *before* operating the machine.

Electric Strike

When an electrical strike occurs, release the *water lance tool* or *pothole excavation tool* immediately. Do Not touch any part of the machine or attached towing vehicle. Do Not allow anyone to approach the machine or towing vehicle.

Have someone clear of the area contact the utility company immediately to shut electrical power off.

NOTE: Some circuit breakers reset automatically. Do Not assume power has been disconnected until utility company confirms power has been locked out to the line.

Gas Strike

Do Not operate machine where flammable gas is present. If you have potholed into an area that has a damaged or leaking gas line, shutdown engine and evacuate the area immediately. Do Not allow anyone to approach the worksite.

Contact the utility company immediately. Do Not return to the worksite until utility company grants permission.

Fiber Optic Strike (Broken Line)

Do Not look into end of any unidentified cable. Fiber optic cables carry laser light, which can result in permanent eye damage. Contact the utility company immediately for assistance.

Preparation - Machine

Machine - Location

- Determine where the machine can be positioned on a stable, level surface before detaching the unit from the towing vehicle.
- Chock all tires before separating machine from towing vehicle.

Machine - Inspection, Maintenance, and Initial Settings

Machine Inspection

Visually inspect machine daily, before starting the engine. Do Not operate the machine if it is not in good operating condition or needs repair. See "Daily Inspection" on page 69.

Daily Maintenance

Perform daily maintenance procedures before starting the machine. See "Section 9: Daily Maintenance" on page 65.

The hourmeter (**C1**) displays the total number of hours the engine has been in operation and is used to determine service intervals. Service intervals are: Daily, As Needed, 50, 100, 200, 400, 800, 1600 hours.

Following recommended, scheduled, maintenance will help prevent costly downtime and repairs.

Initial Operational Settings

Configure the machine for start-up. See "Operational Settings - Initial" on page 51.

End of Section.
This page intentionally left blank.

Section 8: Operating the Machine

IMPORTANT: Read and understand all Safety Messages. See "Section 1: Safety Messages" on page 7.

NOTE: See "Section 3: Component Identification" on page 17.

Pre-Operation Information and Precautions

Preparation - Operator, Worksite, and Machine

Ensure all necessary preparations have been met regarding the operator, worksite, and machine. See "Section 7: Preparation" on page 43.

Daily Inspection and Maintenance

Visually inspect machine daily, before starting the engine. See "Daily Inspection" on page 69. Do Not operate the machine if it is not in good operating condition or needs repair.

Perform daily maintenance procedures before starting the machine. "Section 9: Daily Maintenance" on page 65. Following recommended, scheduled maintenance will help prevent costly downtime and repairs.

The hourmeter (**C1**) displays the total number of hours the engine has been in operation and is used to determine service intervals. Service intervals are: Daily, As Needed, 50, 100, 200, 400, 800, 1600 hours.

Freezing Conditions

IMPORTANT: Be prepared to winterize the water system immediately after using water tools. See "Shutdown - Freezing Conditions" on page 30.

Low Water Level Automatic Shutoff

When the water tank level is low, the water pump automatically turns off to prevent the water pump from running dry. Fill water tanks before resuming operation.

Blower Protection

NOTE: Maintaining collection tank primary shutoff and the bag house filter system are critical for maximizing blower service life.

Primary Blower Protection - Primary Shutoff

As the collection tank fills, a float ball (**V7**) seals off the suction line. Vacuum tools will no longer have suction and the engine will pull down.

NOTE: Shutdown machine when engine pulls down to prevent blower from overheating. Dump collection tank contents before starting the machine again. See "Dump Collection Tank - Rear Door Fully Open" on page 56 or "Dump Collection Tank - Pressurized Unloading" on page 58.

Secondary Blower Protection - Bag House

The bag house protects the blower by filtering moisture and debris that has made its way past the primary shutoff.

NOTE: Back pressure clean the bag house filters daily or each time collection tank is emptied. See "Back-Pressure Cleaning" on page 62.

NOTE: *Drain bag house (V10)* daily or each time collection tank is emptied.

Operational Settings - Initial

1: Configure machine as follows:

- *Water Pump Switch (W1)*OFF
- *Suction Valve (V1)*..... CLOSED
- *Dump Valve (V3)*..... CLOSED
- *Rear Door Lever (V2)*..... LATCHED
- *Bag House Drain Valve (V10)*..... OPEN
- *Pressure/Vacuum Selector Lever (V6)*..... NEUTRAL
(if equipped)

2: Begin desired operation. See:

- "Operation - Water Only (High-Pressure)" on page 52.
- "Operation - Vacuum Only" on page 53.
- "Operation - Excavating (Water and Vacuum)" on page 54.

Operation - Water Only (High-Pressure)

- 1: Configure machine to initial operation settings. See "Operational Settings - Initial" on page 51.
- 2: Start engine. See "Section 4: Starting Procedure" on page 27.

NOTE: Allow engine to warm up at LOW idle.

- 3: Unwind water hose from reel.
- 4: Connect high-pressure water hose quick coupler (**T2**) to *water wand handle* or *water lance handle* (**T9**).
- 5: While engine is still at LOW idle, turn *water pump switch* (**W1**) ON.
- 6: Increase *throttle* (**C11**) to HIGH (FULL).

IMPORTANT: Do Not point tool at people. Keep feet clear of high-pressure water spray.

NOTE: Do Not use the *water lance tool* or *pothole excavation tool* to wash or clean machine components. The high-pressure rotary nozzle spray can easily remove paint or damage components.

- 7: Squeeze trigger for high-pressure water. Release trigger to stop flow.
- 8: Complete high-pressure work as needed and shutdown machine. See "Section 5: Shutdown Procedures" on page 29.

Operation - Vacuum Only

- 1: Configure machine to initial operational settings. See "Operational Settings - Initial" on page 51.
- 2: Connect *vacuum tool* (T8) to *vacuum hose* (T6).
- 3: Connect *vacuum hose* to *suction valve* (V1).
- 4: Start engine. See "Section 4: Starting Procedure" on page 27.

NOTE: Allow engine to warm up at LOW idle.

- 5: Set *throttle* (C11) to HIGH (FULL).

NOTE: Engine speed has been set at the factory to ensure the blower operates at the manufacturer's recommended RPM. Do Not change the engine speed. Blower damage may occur if operated above or below the recommended RPM.

- 6: CLOSE *bag house drain valve* (V10).
- 7: OPEN *suction valve*.
- 8: Set *pressure/vacuum selector lever* (V6) (if equipped) to VACUUM.
- 9: Place *vacuum tool* in or near spoil.

NOTE: Whenever vacuuming is stopped for a period of time (while engine continues to run) OPEN *bag house drain valve* or *suction valve* and set *pressure/vacuum selector lever* (if equipped) to VACUUM, allowing blower to cool down.

NOTE: Shutdown machine when engine pulls down to prevent blower from overheating. Dump collection tank contents before starting the machine again. See "Dump Collection Tank - Rear Door Fully Open" on page 56 or "Dump Collection Tank - Pressurized Unloading" on page 58.

- 10: Complete cleanup and shutdown machine. See "Section 5: Shutdown Procedures" on page 29.

NOTE: Drain bag house (V10) daily or each time collection tank is emptied.

NOTE: Back pressure clean the bag house filters daily or each time collection tank is emptied. See "Back-Pressure Cleaning" on page 62.

Operation - Excavating (Water and Vacuum)

- 1: Configure machine to initial operation settings. See "Operational Settings - Initial" on page 51.
- 2: Connect *pothole excavation tool (T5)* to high-pressure *water quick connector (T7)*, and *vacuum hose (T6)*.
- 3: Connect *vacuum hose* to *suction valve (V1)*.
- 4: Start engine. See "Section 4: Starting Procedure" on page 27.

NOTE: Allow engine to warm up at LOW idle.

- 5: Set *throttle (C11)* to HIGH (FULL).

NOTE: Engine speed has been set at the factory to ensure the blower operates at the manufacturer's recommended RPM. Do Not change the engine speed. Blower damage may occur if operated above or below the recommended RPM.

- 6: Set *pressure/vacuum selector lever (V6)* (if equipped) to VACUUM.
- 7: CLOSE *bag house drain valve (V10)*.
- 8: OPEN *suction valve*.

IMPORTANT: Do Not point tool at people. Keep feet clear of high-pressure water spray.

- 9: Position tool above potholing (excavation) location.
- 10: Shoot 2–3 short blasts of high-pressure water to clean out *pothole excavation tool* chamber and ensure nozzle rotates properly.
- 11: Hold trigger for a constant supply of high-pressure water.
- 12: Move tool in an orbital pattern to enlarge hole diameter.
- 13: As tool nears target depth, frequently release trigger, remove tool, and check for exposed utility.

IMPORTANT: Release trigger immediately after locating utility.

14: Increase hole size or move to a new location if utility cannot be located.

NOTE: Whenever vacuuming is stopped for a period of time (while engine continues to run) OPEN *bag house drain valve* or *suction valve* and set *pressure/vacuum selector lever* (if equipped) to VACUUM, allowing blower to cool down.

NOTE: Shutdown machine when engine pulls down to prevent blower from overheating. Dump collection tank contents before starting the machine again. See "Dump Collection Tank - Rear Door Fully Open" on page 56 or "Dump Collection Tank - Pressurized Unloading" on page 58.

15: Complete excavating/potholing as needed and shutdown machine. See "Section 5: Shutdown Procedures" on page 29.

NOTE: Drain bag house (**V10**) daily or each time collection tank is emptied.

NOTE: Back pressure clean the bag house filters daily or each time collection tank is emptied. See "Back-Pressure Cleaning" on page 62.

Dump Collection Tank - Rear Door Fully Open

- 1: Park machine on a stable, level surface.
- 2: OPEN *bag house drain valve (V10)*.
- 3: Start engine. See "Section 4: Starting Procedure" on page 27.

NOTE: Allow engine to warm up at LOW idle.

- 4: While engine is still at LOW idle, turn *water pump switch (W1)* ON.
- 5: Increase *throttle (C11)* to HIGH (FULL).

NOTE: Engine speed has been set at the factory to ensure the blower operates at the manufacturer's recommended RPM. Do Not change the engine speed. Blower damage may occur if operated above or below the recommended RPM.

- 6: Set *pressure/vacuum selector lever (V6)* (if equipped) to VACUUM.
- 7: CLOSE *bag house drain valve*.
- 8: CLOSE *suction valve (V1)*.
- 9: OPEN *dump valve (V3)*. Incoming air will provide mixing action and move solids away from the *dump valve*. Allow this mixing action to continue for 1–2 minutes. This procedure creates a slurry in the tank.

NOTE: The *dump valve* may be clogged. If so, remove *water wand extension (T3)* and shoot a stream of water directly into the *dump valve* using the *water wand handle (T4)* only. The blockage should be easily cleared within a few seconds.

NOTE: Do Not use the *water lance tool* or *pothole excavation tool* to wash or clean machine components. The high-pressure rotary nozzle spray can easily remove paint or damage components.

- 10: Slowly CLOSE *dump valve*.
- 11: Allow vacuum to build in collection tank.
- 12: Use *rear door latch lever (V2)* to UNLATCH rear door.

- 13:** OPEN *bag house drain valve* or *suction valve* to relieve vacuum in collection tank. Leave the *bag house drain valve* OPEN.
- 14:** Set *pressure/vacuum selector lever* (if equipped) to NEUTRAL.
- 15:** Use *rear door raise/lower control (H2)* to fully OPEN rear door.
- 16:** Use *collection tank raise/lower control (H1)* to raise the collection tank and dump contents.
- 17:** Lower collection tank.
- 18:** Wash collection tank interior. See "Collection Tank - Clean Interior" on page 60.

IMPORTANT: Ensure bag house drain valve is OPEN and *vacuum/pressure selector lever* (if equipped) is in NEUTRAL to prevent water from being pulled into the bag house and potentially into the blower.

NOTE: Drain bag house (**V10**) daily or each time collection tank is emptied.

NOTE: Back pressure clean the bag house filters daily or each time collection tank is emptied. See "Back-Pressure Cleaning" on page 62.

- 19:** Shutdown machine. See "Section 5: Shutdown Procedures" on page 29.

Dump Collection Tank - Pressurized Unloading

NOTE: This procedure works only with machines equipped with a *pressure/vacuum selector lever (V6)*.

- 1:** Park machine on a stable, level surface.
- 2:** Set *pressure/vacuum selector lever* to NEUTRAL.
- 3:** Start engine. See "Section 4: Starting Procedure" on page 27.

NOTE: Allow engine to warm up at LOW idle.

- 4:** While engine is still at LOW idle, turn *water pump switch (W1)* ON.
- 5:** Increase *throttle (C11)* to HIGH (FULL).

NOTE: Engine speed has been set at the factory to ensure the blower operates at the manufacturer's recommended RPM. Do Not change the engine speed. Blower damage may occur if operated above or below the recommended RPM.

- 6:** Set *pressure/vacuum selector lever (V6)* (if equipped) to VACUUM.
- 7:** CLOSE *bag house drain valve (V10)*.
- 8:** CLOSE *suction valve (V1)*.
- 9:** OPEN *dump valve (V3)*. Incoming air will provide mixing action and move solids away from the dump valve. *Allow this mixing action to continue for 1–2 minutes.* This procedure creates a slurry in the tank.

NOTE: The dump valve may be clogged. If so, remove *water wand extension (T3)* and shoot a stream of water directly into the dump valve using the *water wand handle (T4)* only. The blockage should be easily cleared within a few seconds.

NOTE: Do Not use the *water lance tool* or *pothole excavation tool* to wash or clean machine components. The high-pressure rotary nozzle spray can easily remove paint or damage components.

IMPORTANT: Keep a sufficient area behind the machine clear of workers, tools, spectators, etc.

- 10:** Set *pressure/vacuum selector lever* (if equipped) to PRESSURE to push liquid spoil out of the *dump valve* under pressure.
- 11:** After tank is drained, return *pressure/vacuum selector lever* (if equipped) to NEUTRAL.
- 12:** CLOSE *dump valve*.
- 13:** Wash collection tank interior. See "Collection Tank - Clean Interior" on page 60.

IMPORTANT: Ensure *bag house drain valve* is OPEN and *vacuum/pressure selector lever* (if equipped) is in Neutral to prevent water from being pulled into the bag house and potentially into the blower.

NOTE: Drain bag house daily or each time collection tank is emptied.

NOTE: Back pressure clean the bag house filters daily or each time collection tank is emptied. See "Back-Pressure Cleaning" on page 62.

- 14:** Shutdown machine. See "Section 5: Shutdown Procedures" on page 29.

Collection Tank - Clean Interior

IMPORTANT: Do Not work under rear door without a suitable prop to secure the door in the raised position. Do Not enter tank.

- 1: Use rear *door raise/lower control (H2)* to fully OPEN door.
- 2: Use *collection tank raise/lower control (H1)* to position tank at a comfortable angle to access tank interior while standing beside the rear door.
- 3: Secure rear door with a suitable prop.

IMPORTANT: Ensure *bag house drain valve (V10)* is OPEN and *vacuum/pressure selector lever* (if equipped) is in NEUTRAL to prevent water from being pulled into the bag house and potentially into the blower.

NOTE: Do Not use the *water lance tool* or *pothole excavation tool* to wash or clean machine components. The high-pressure rotary nozzle spray can easily remove paint or damage components.

- 4: Wash:
 - primary shutoff assembly and ball (V7)
 - tank interior
 - door seal (take care not to damage the seal with pressurized water)
 - contact surface of door
 - *suction valve (V1)* and *drain valve (V3)* to help keep build up from forming and inhibiting lever from moving freely.
 - other surfaces and tools as needed

NOTE: Keep high-pressure water spray from coming into contact with electrical components.

- 5: Use *collection tank raise/lower lever* to lower tank.
- 6: Use *rear door raise/lower lever* to fully CLOSE rear door.
- 7: Set *pressure/vacuum selector lever (V6)* (if equipped) to VACUUM.
- 8: CLOSE *bag house drain valve* and allow vacuum to build in collection tank.

- 9:** Use *rear door latch lever (V2)* to secure rear door in the closed position.
- 10:** Set *pressure/vacuum selector lever* (if equipped) to NEUTRAL.
- 11:** OPEN *bag house drain valve* to relieve collection tank vacuum.
- 12:** Set *throttle (C11)* to LOW idle.
- 13:** Turn *water pump switch (W1)* OFF.
- 14:** Shutdown machine. See "Section 5: Shutdown Procedures" on page 29.
- 15:** Store and secure hoses and tools on machine. See "Tools (T)" on page 24.

Back-Pressure Cleaning

Bag House Filters - Back-Pressure Cleaning

NOTE: This procedure works only with machines equipped with a *pressure/vacuum selector lever (V6)*.

NOTE: Drain the bag house and Back-Pressure clean with every load.

- 1: CLOSE *suction valve (V1)* and *dump valve (V3)*.
- 2: OPEN *bag house drain valve (V10)*.
- 3: Set *pressure/vacuum selector lever* (if equipped) **(V6)** to PRESSURE.
- 4: Start engine. See "Section 4: Starting Procedure" on page 27.
- 5: Allow engine to warm up.
- 6: Set *throttle (C11)* to HIGH (FULL). Back-pressure will push debris off the filters and out of the bag house drain.
- 7: Shutdown machine. See "Section 5: Shutdown Procedures" on page 29.

Vacuum Hose - Back-Pressure Cleaning

NOTE: This procedure works only with machines equipped with a *pressure/vacuum selector lever (V6)*.

- 1: Ensure vacuum hose is securely connected to *suction valve (V1)* and will stay pointed in a safe direction.
- 2: OPEN *suction valve*.
- 3: CLOSE *dump valve (V3)*.
- 4: CLOSE *bag house drain valve (V10)*.
- 5: Set *pressure/vacuum selector lever* to PRESSURE.
- 6: Start engine. See "Section 4: Starting Procedure" on page 27 and allow engine to warm up.
- 7: Set *throttle (C11)* to HIGH (FULL). Back-pressure will push debris and blockages out of the suction hose.
- 8: Shutdown machine. See "Section 5: Shutdown Procedures" on page 29.

Vacuum Hose - Wash Interior

- 1:** Remove tool from vacuum hose end and place hose end near the *water tank drain valve (W8)*.
- 2:** Ensure vacuum hose is securely connected to *suction valve (V1)* and will stay pointed in a safe direction.
- 3:** OPEN *suction valve*.
- 4:** CLOSE *dump valve (V3)*.
- 5:** CLOSE *bag house drain valve (V10)*.
- 6:** Set *pressure/vacuum selector lever (V6)* to VACUUM.
- 7:** Start engine. See "Section 4: Starting Procedure" on page 27 and allow engine to warm up.
- 8:** Set *throttle (C11)* to HIGH (FULL).
- 9:** OPEN *water tank drain valve*.
- 10:** Hold *suction hose* end under *water tank drain valve* until hose interior is washed clean (usually takes only a few seconds).
- 11:** Lay hose down where it will stay pointed in a safe direction.
- 12:** Close *water tank drain valve*.
- 13:** Shutdown machine. See "Section 5: Shutdown Procedures" on page 29.

End of Section.

This page intentionally left blank.

Section 9: Daily Maintenance

IMPORTANT: Read and understand all Safety Messages. See "Section 1: Safety Messages" on page 7.

NOTE: See "Section 3: Component Identification" on page 17.

Refer to the Maintenance Manual for more detailed information and for service intervals greater than those listed in this section.

This section is divided into the following sub categories:

- General Information
- Daily Engine Maintenance
- Daily Machine Maintenance

IMPORTANT: Perform daily maintenance and inspection before starting the engine Do Not operate the machine if it is not in good operating condition or needs repair.

IMPORTANT: Factory Settings:

- Vacuum Relief and Water Pressure have been pre-set at the factory. Do Not exceed factory settings. Refer to the Maintenance Manual for more information and procedures on these systems.
- Collection Tank Pressure Relief has been pre-set at the factory. ***Do Not adjust Collection Tank Pressure Relief.***

NOTE: Operating under severe conditions may require shorter service intervals. Contact your authorized Ring-O-Matic Dealer for more information.

NOTE: Some engines are equipped with an oil pressure sensor. When oil pressure drops below an acceptable threshold, the engine will run for approximately five seconds and then shutdown.

Daily Maintenance Charts are provided on the following pages.

The following OEM manuals are supplied with each machine. Reference these manuals for detailed information and maintenance procedures.

- Axle Manual
- Blower Manual
- Engine Manual
- Water Pump Manual

General Maintenance Information

High-Pressure Water

Pressurized water can cause serious injury or death. Pressurized water can also remove paint, damage the door seal, or destroy electronic seals and/or components.

NOTE: Do Not use the *water lance tool* or *pothole excavation tool* to wash or clean machine components. The high-pressure rotary nozzle spray can easily remove paint or damage components.

Hourmeter

The hourmeter **(C1)** displays the total number of hours the engine has been in operation and is used to determine service intervals. Service intervals are: Daily, As Needed, 50, 100, 200, 400, 800, 1600 hours.

Inspection

Visually inspect machine daily, before starting the engine. Do Not operate the machine if it is not in good operating condition or needs repair.

Lubricants

Use only the specified lubricants. See "Lubricants" on page 81.

Maintenance Service Intervals and Procedures

Following recommended, scheduled maintenance will help prevent costly downtime and repairs.

Do Not attempt any maintenance procedure that is not fully understood, or that cannot be safely and accurately performed with available tools and equipment. When an issue is encountered that is not fully understood or cannot be solved, contact your authorized Ring-O-Matic dealer.

Refer to the Maintenance Manual for more detailed information and for service intervals greater than those listed in this section.

Modifications

Make no modifications to the machine unless specifically approved (in writing) or recommended by Ring-O-Matic. Unauthorized modifications (including welding) will void the warranty.

Photos and Illustrations

Photographs and illustrations are included for representation purposes only. Actual appearance may vary by model.

Safety Shields

Photographs or illustrations may have safety shields removed to provide a better view of specific components.

Keep all shields in place and securely mounted. Do Not operate the machine with any safety shield removed. Whenever necessary to remove a safety shield to perform a maintenance procedure, always install the shield properly before starting the machine.

Severe Application

Operating under severe conditions may require shorter service intervals.

Severe application factors include (but are not limited to): unusually high or low ambient temperatures; dusty environments; high and/or extended load factors; and extended periods of time idling.

Machines used near salt water require special washing and cleaning considerations.

Contact your authorized Ring-O-Matic Dealer for more information.

Specifications

See "Section 12: Specifications" on page 81.

Visit our web site www.ring-o-matic.com for more detailed specifications and the most current information.

Storage and Start-Up Procedures

See the Maintenance Manual.

Troubleshooting

See the Maintenance Manual.

Winterizing the Water System

See "Winterizing the Water System (Option)" on page 30.

Daily Engine Maintenance Chart

DIESEL ENGINE	DAILY
Air Cleaner Service Indicator (if equipped) - Check	•
Driven Equipment and Overall Inspection - Check	•
Engine Compartment - Keep Clean	•
Fluid Levels (Oil and Coolant) - Check	•
Fuel/Water Separator - Drain	•

Daily Machine Maintenance Chart

MACHINE	DAILY
Bag House - Back-Pressure Clean (option)	•
Bag House - Drain (with each load)	•
Blower Oil Level - Check	•
Daily Inspection	•
Fuel Tank - Fill (helps prevent condensation)	•
Highway Lights - Test	•
Hydraulic Fluid Level - Check	•
Primary Shutoff - Wash	•
Tire Pressure and Lug Nuts - Check	•
Towing Chain and Slip Hooks - Inspect	•
Trailer Break-Away System - Check Battery and Cable	Before Each Trip
Vacuum Hose - Inspect and Clean	•
Water Pump Oil Level - Check	•
Water Strainer - Clean and Inspect for Damage	•
Water Tank - Drain or Fill	•

Daily Inspection

IMPORTANT: Inspect the machine daily, before starting the engine. Do Not operate the machine if it is not in good operating condition or needs repair.

- **Electrical Harnesses:** Ensure electrical harness and wires are properly supported, connected, and not rubbing on any sharp edges.
- **Fire Prevention:** Keep engine area or compartment clean. Do Not allow trash, grease, or debris to accumulate near the engine.
- **Frame:** Inspect frame for bends, cracks, or breaks. Contact Ring-O-Matic immediately if any problems are found with the frame. Do Not tow machine with a compromised frame.
- **Hardware:** Inspect the machine for damaged, loose, missing, or worn parts and hardware. Tighten loose parts and replace parts as needed.
- **Highway Lights:** Ensure tail lights, brake lights, signal lights, and back-up lights function properly.
- **Hour Meter:** Check for scheduled maintenance (scheduled service intervals occur Daily, As Needed, 50, 100, 200, 400, 800, and 1600 hours).
- **Leaks:** Check for signs of leaks on engine, hoses, fittings and machine components. Repair or replace as needed.
- **Reflectors:** Ensure reflectors and reflector tape are present and clean. Replace missing or damaged reflective materials.
- **Shields and Guards:** Ensure shields and guards are installed and securely fastened to machine. Replace or repair any shield or guard that is damaged or has missing parts.
- **Skid Mounted Machines:** Check mounting hardware. Tighten or replace hardware as needed.
- **Trailer Mounted Machines:**
 - Inspect trailer Break-Away System cable and check battery charge before each trip.
 - Inspect safety tow chains and slip hooks. Repair or replace components as needed with equal size and rated parts before moving the machine.
 - Inflate tires to recommended pressure as stated on the tire sidewall. Do Not over-inflate.
 - Check for loose, damaged or missing lug nuts. Tighten or replace as needed.
 - Do Not move machine with defective, worn, damaged, or missing trailer components.

Trailer Break-Away System Battery and Cable - Check Each Trip

The Break-Away System box and connecting cable are located in the trailer tongue directly behind the hitch or pintle ring.

Break-Away System Cable - Inspect

Ensure break-away cable is in good condition. Replace as needed.

Break-Away System Battery - Test

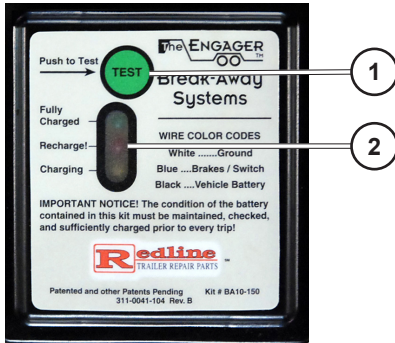

IMPORTANT: The battery must be tested before every trip.

Press battery test button (1) and view indicator lights (2):

- GREEN Fully Charged
- RED Low (Recharge)
- AMBER Charging

Break-Away System Battery - Charge

- 1: Connect trailer electrical connector to towing vehicle.
- 2: Start towing vehicle engine and allow vehicle to idle. A full charge should be obtained within 20 minutes.

IMPORTANT: If battery does not charge fully, replace the Break-Away System before towing the trailer.

Tire Pressure and Lug Nuts - Check Daily

- Check tire pressure.
 - Inflate to recommended pressure as stated on the tire sidewall.
 - Do Not over-inflate.
- Check for loose, damaged, or missing lug nuts.
 - Tighten or replace as needed.
 - See "Machine Specifications" on page 82 for torque specs.

End of Section.

This page intentionally left blank.

Section 10: Warranty

New Industrial Equipment Limited Warranty

Warranty Period: 12 Months or 1,000 Hours

Ring-O-Matic warrants each new Industrial Product of Ring-O-Matic's manufacture to be free from defects in material and workmanship, under normal use and service for one (1) full year after initial purchase/retail sale or 1,000 operating hours, whichever occurs first. This Limited Warranty shall apply only to complete machines of Ring-O-Matic's manufacture, parts are covered by a separate Limited Warranty.

Equipment and accessories not of Ring-O-Matic's manufacture are warranted only to the extent of the original manufacturer's warranty and subject to their allowance to Ring-O-Matic (only if found to be defective by such manufacturer).

Warranty Terms

During the Limited Warranty period specified above, any defect in material or workmanship in any warranted item of Ring-O-Matic Industrial Equipment not excluded below shall be repaired or replaced at Ring-O-Matic's option without charge by an authorized independent Ring-O-Matic dealer. The warranty repair or replacement must be made by a Ring-O-Matic independent authorized dealer at the dealer's location. Ring-O-Matic will pay for replacement parts and reserves the right to supply remanufactured replacement parts, as deemed appropriate.

Retail Purchaser Responsibility

This Limited Warranty requires proper maintenance and periodic inspections of the Industrial Equipment as indicated in the Operator's/Maintenance Manual furnished with each new machine. The cost of routine or required maintenance and services is the responsibility of the retail purchaser. NOTE: The retail purchaser is required to keep documented evidence that routine or required maintenance services were performed.

This Ring-O-Matic New Industrial Equipment Limited Warranty may be subject to cancellation if the above requirements are not performed. Ring-O-Matic Industrial Equipment, with known failed or defective parts, must be immediately removed from service.

The original Warranty Validation Form must be completed, signed, and returned to Ring-O-Matic within ten (10) days from date of purchase.

Exclusions and Limitations

The warranties contained herein SHALL NOT APPLY TO:

- 1:** New Industrial Equipment delivered to the retail purchaser in which the original Warranty Validation Form has not been completed, signed, and returned to Ring-O-Matic within ten (10) days from the date of purchase.
- 2:** Any defect which was caused (in Ring-O-Matic's sole judgment) by other than normal use and service of the Industrial Equipment, or by any of the following:
 - accidents
 - alteration(s) or modification(s) not approved by Ring-O-Matic
 - collision or vehilce accident
 - the elements
 - freezing water
 - high-pressure washing
 - improper repair or installation
 - improper storage
 - lack of reasonable and proper maintenance
 - misuse or negligence
 - natural calamities
 - overloading
 - parts or accessories installed on Industrial Equipment which were not manufactured or installed by Ring-O-Matic authorized dealers
 - vandalism
 - water damage
 - welding, welding currents, or weld spatter
- 3:** Any Industrial Equipment whose identification numbers or marks have been altered or removed or whose hour meter has been altered or tampered with.
- 4:** Any Industrial Equipment which any of the required or recommended periodic inspection or services have been performed using parts not manufactured or supplied by Ring-O-Matic or meeting Ring-O-Matic specifications including, but without limitation, engine tune-up parts, engine oil filters, air filters, hydraulic oil filters, and fuel filters.

- 5:** Any defect which was caused (in Ring-O-Matic's sole judgment) by operation of the Industrial Equipment not abiding by standard operating procedures outlined in the Operator's Manual.
- 6:** Transportation costs, if any, to or from an authorized Ring-O-Matic dealer.
- 7:** Travel time of Ring-O-Matic dealer's service personnel to make a repair on the retail purchaser's site or other location.
- 8:** In no event shall Ring-O-Matic's liability exceed the purchase price of the component(s) or product(s).
- 9:** Ring-O-Matic shall not be liable to any person, under any circumstances, for any incidental or consequential damages (including but not limited to, loss of profits, out of service time) occurring for any reason at any time.
- 10:** Diagnostic and overtime labor premiums are not covered under this Limited Warranty Policy.
- 11:** Depreciation damage caused by normal wear, lack of reasonable and proper maintenance, failure to follow operating instructions, misuse, or lack of proper protection during storage.
- 12:** Accessory systems or electronic components not of Ring-O-Matic's manufacture are warranted only to the extent of such manufacturer's respective Limited Warranty, if any.
- 13:** Tools are not covered under this warranty.
- 14:** OEM Components: Battery, Blower, Clutch, Electronic Controllers/ Modules/Computers, Engine, Gauges, Hydraulic Pump, Tires, Valve Exercising Arm, or Water Pump. Warranty and support of these items are the sole responsibility of the component's manufacturer.
- 15:** ***Consumables and Wear Items:*** Air Filters, Air Pre-Cleaner, Ball Valves, Bag House Filters, Bearings, Belts, Booms, Brake Pads, Bushings, Clutch Components, Fuel Filters, High-Pressure Water Hose, High-Pressure Water Nozzles, Oil Filters, Optional Accessories, Primary and Scrubber Filters, Pressure Relief Valves, Regulating Unloader Valve, Shut-Off Guns, Screens, Shut-Off Valves, Vacuum Hoses, or Vacuum Relief Valve.

Parts Warranty

Parts replaced in the warranty period will receive the balance of the first year New Industrial Equipment Limited Warranty, during the first twelve (12) months, or 1,000 hours whichever comes first.

Replacement parts after the original machine warranty, are warranted to be free from defects of material for thirty (30) days or the part will be repaired or replaced (by Ring-O-Matic's sole judgment). Removal and reinstallation labor is not covered.

All parts warranty claims must be filed within ten (10) working days of initial part failure or the warranty claim will be void.

Exclusions of Warranties

Except for the warranties expressly and specifically made herein, Ring-O-Matic makes no other warranties, and any possible liability of Ring-O-Matic hereinafter is in lieu of all other warranties, express, implied, or statutory, including, but not limited to, any warranties of merchantability or fitness for a particular purpose. Ring-O-Matic reserves the right to modify, alter and improve any product without incurring any obligation to replace any product previously sold with such modification. No person is authorized to give any other warranty, or to assume any additional obligation on Ring-O-Matic's behalf.

Manufactured by:

**Ring-O-Matic
1714 Fifield Road
Pella, Iowa 50219
U.S.A.**

Section 11: Receiving and Delivery

Dealer Preparation

Check or perform the following:

Engine

- Check battery charge
- Check air cleaner system
- Check engine oil level
- Check coolant level (if equipped)
- Check engine operation
- Check gauges for proper operation

Hydraulics

- Check hydraulic fluid level
- Check hydraulic control operation
- Check hydraulic components for leaks or damage

General

- Check that the Operator Manual is in the black box on the machine
- Check for shipping damage or shortage
- Check that all optional and loose items are included with the machine
- Check machine lubrication
- Check blower oil level
- Check water pump oil level
- Check blower and water pump drive belt tension
- Check installation and condition of shields
- Check bolts for tightness
- Check decal condition
- Check all phases of operation for proper functionality
- Complete "Dealer Information" on page 79
- Complete "Original Owner Information" on page 79
- Complete "Identification Numbers - Record" on page 80

Delivery to Customer

Check and perform the following with the customer:

Review of Operation

Review and demonstrate with the customer:

- ___ Overview of how the machine works
- ___ Preparing the machine for operation
- ___ Pressurized water safety
- ___ Vacuum system safety
- ___ Operational safety
- ___ All safety decals
- ___ All safety messages. See "Section 1: Safety Messages" on page 7.
- ___ High-pressure water operation
- ___ Potholling (Excavation) operation
- ___ Vacuum only operation
- ___ Filling the spoils tank
- ___ Dumping the spoils tank
- ___ Pressurized dumping the spoils tank (if equipped)
- ___ Ensure customer understands shutdown procedures. See "Section 5: Shutdown Procedures" on page 29.
- ___ All sections in this manual

Dealer Information	
Company Name:	
Address:	
City:	
State / Province:	
Zip / Postal Code:	
Country:	
Phone Number(s):	

Original Owner Information	
Owner:	
Address:	
City:	
State / Province:	
Zip / Postal Code:	
Country:	

Identification Numbers - Record

Machine Serial Number

Model #: _____

V.I.N. #: _____



Engine Serial Number

Model #: _____

Serial #: _____

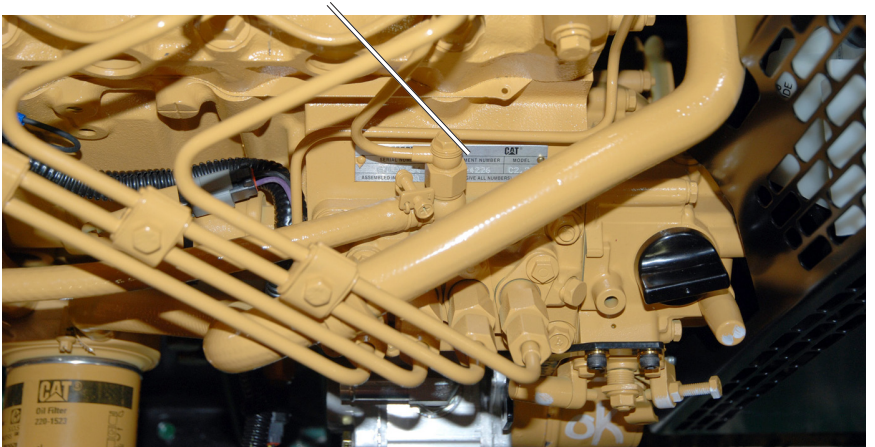

Section 12: Specifications

IMPORTANT: Read and understand all Safety Messages. See "Section 1: Safety Messages" on page 7.

NOTE: See "Section 3: Component Identification" on page 17.

Visit our web site www.ring-o-matic.com for more detailed specifications and the most current information.

Lubricants

NOTE: Ensure machine is on a level surface before checking fluid levels.

AXLE

Refer to the Axle Manual supplied with each machine.

BLOWER

Refer to the Blower Manual supplied with each machine.

ENGINE

Refer to the Engine Manual supplied with each machine.

WATER PUMP

Refer to the Water Pump Manual supplied with each machine.

HYDRAULIC FLUID	Capacity	Notes
Dextron III - Type A Auto-Transmission Fluid	Fill to Sight-Eye Level	<ul style="list-style-type: none"> • Filter fluid through 10-micron filter • Keep contaminants out of system • Leave 1.5" (4cm) expansion room

GREASE POINTS	Capacity	Notes
Grease: Pennzoil 705	4-Way Valve: 2 shots weekly	<ul style="list-style-type: none"> • Do Not mix different grease types • Replace missing fittings • Clean fittings before greasing • Clean grease gun tip • Do Not over grease • Blower: Use manual grease gun only or seals may be compromised
	Misc. Machine: 2 shots monthly	
	Blower: 6 shots every 400 hrs	

Machine Specifications

Visit our web site www.ring-o-matic.com for more detailed specifications and the most current information.

This section is organized by machine model. The following information is provided for each model:

- Tire Specifications
 - Size
 - Cold Pressure
 - Lug Nut Torque
- Trailer Tongue Weight
 - Dry
 - Wet
- Machine Weights
 - GVWR (Gross Vehicle Weight Rating)
 - Machine Only (no spoil, no water)
 - Maximum Cargo (spoil and water)
- Tank Capacities
 - Collection Tank
 - Fresh Water Tank(s)

Specifications: 275 VacEx

Tires

275 VacEx	Specification
Tire Size	ST235/80 R16 Load Range E
Cold Pressure	Do Not under inflate or over inflate. Follow manufacturer’s specification on tire sidewall
Lug Nut Torque	95 ft-lb (130 Nm)

Tongue Weight

275 VacEx	Weight (Approximate)	Notes
Tongue Weight - Dry	1,120 lb (510 kg)	water tank empty; collection tank empty
Tongue Weight - Wet		water tank full; collection tank full with 8.35 lb/gal (1.00 kg/L) spoil density *

GVWR; Dry Weight; Maximum Cargo Weight

275 VacEx	Weight	Notes
GVWR	8,000 lb (3630 kg)	WARNING: DO NOT EXCEED GVWR
Machine Only (dry) (No Spoil, No Water)	4,260 lb (1930 kg)	
Maximum Cargo (Spoil* and Water)	3740 lb (1700 kg)	

Tank Capacities

275 VacEx	Capacity	Notes
Collection Tank	250 gal (950 L)	spoil weight varies by material type*
Fresh Water Tank(s)	100 gal (375 L)	water weighs 8.35 lbs/gal (1.00 kg/L)

*** IMPORTANT:** Spoil types range in density from approximately 9 lb/gallon (1.1 kg/L) to over 17 lb/gallon (2 kg/L). See "Spoil Density Chart" on page 88.

Specifications: 550 VacEx

Tires

550 VacEx	Specification
Tire Size	ST235/80 R16 Load Range E
Cold Pressure	Do Not under inflate or over inflate. Follow manufacturer's specification on tire sidewall
Lug Nut Torque	95 ft-lb (130 Nm)

Tongue Weight

550 VacEx	Weight (Approximate)	Notes
Tongue Weight - Dry	1,100 lb (500 kg)	water tank empty; collection tank empty
Tongue Weight - Wet	840 lb (380 kg)	water tank full; collection tank full with 8.35 lb/gal (1.00 kg/L) spoil density *

GVWR; Dry Weight; Maximum Cargo Weight

550 VacEx	Weight	Notes
GVWR	13,000 lb (5900 kg)	WARNING: DO NOT EXCEED GVWR
Machine Only (dry) (No Spoil, No Water)	6,080 lb (2760 kg)	
Maximum Cargo (Spoil* and Water)	6,920 lb (3140 kg)	

Tank Capacities

550 VacEx	Capacity	Notes
Collection Tank	550 gal (2075 L)	spoil weight varies by material type*
Fresh Water Tank(s)	200 gal (750 L)	water weighs 8.35 lb/gal (1.00 kg/L)

* **IMPORTANT:** Spoil types range in density from approximately 9 lb/gallon (1.1 kg/L) to over 17 lb/gallon (2 kg/L). See "Spoil Density Chart" on page 88.

Specifications: 850 VacEx

Tires

850 VacEx	Specification
Tire Size	235/75 R17.5 Load Range H
Cold Pressure	Do Not under inflate or over inflate. Follow manufacturer’s specification on tire sidewall
Lug Nut Torque	200 ft-lb (270 Nm)

Tongue Weight

850 VacEx	Weight (Approximate)	Notes
Tongue Weight - Dry	840 lb (380 kg)	water tank empty; collection tank empty
Tongue Weight - Wet	1040 lb (470 kg)	water tank full; collection tank full with 8.35 lb/gal (1.00 kg/L) spoil density *

GVWR; Dry Weight; Maximum Cargo Weight

850 VacEx	Weight	Notes
GVWR	20,840 lb (9460 kg)	WARNING: DO NOT EXCEED GVWR
Machine Only (dry) (No Spoil, No Water)	7520 lb (3410 kg)	
Maximum Cargo (Spoil* and Water)	13,320 lb (6050 kg)	

Tank Capacities

850 VacEx	Capacity	Notes
Collection Tank	800 gal (3025 L)	spoil weight varies by material type*
Fresh Water Tank(s)	500 gal (1900 L)	water weighs 8.35 lb/gal (1.00 kg/L)

*** IMPORTANT:** Spoil types range in density from approximately 9 lb/gallon (1.1 kg/L) to over 17 lb/gallon (2 kg/L). See "Spoil Density Chart" on page 88.

Specifications: 1300 VacEx

Tires

1300 VacEx - Trailer	Specification
Tire Size	235/75 R17.5 Load Range H
Cold Pressure	Do Not under inflate or over inflate. Follow manufacturer's specification on tire sidewall
Lug Nut Torque	200 ft-lb (270 Nm)

Tongue Weight

1300 VacEx - Trailer	Weight (Approximate)	Notes
Tongue Weight - Dry		water tank empty; collection tank empty
Tongue Weight - Wet		water tank full; collection tank full with 8.35 lb/gal (1.00 kg/L) spoil density *

GVWR; Dry Weight; Maximum Cargo Weight

1300 VacEx Trailer & Skid Mount	Weight			Notes
GVWR	Skid:	29,600 lb	(13440 kg)	WARNING: DO NOT EXCEED GVWR
	Trailer:	31,000 lb	(14075 kg)	
Machine Only (dry) (No Spoil, No Water)	Skid:	7,140 lb	(3240 kg)	
	Trailer:	8,520 lb	(3870 kg)	
Maximum Cargo (Spoil* and Water)	Skid:	22,460 lb	(10200 kg)	
	Trailer:	22,480 lb	(10205 kg)	

Tank Capacities

1300 VacEx Trailer & Skid Mount	Capacity	Notes
Collection Tank	1300 gal (4925 L)	spoil weight varies by material type*
Fresh Water Tank(s)	500 gal (1900 L)	water weighs 8.35 lb/gal (1.00 kg/L)

* **IMPORTANT:** Spoil types range in density from approximately 9 lb/gallon (1.1 kg/L) to over 17 lb/gallon (2 kg/L). See "Spoil Density Chart" on page 88.

Specifications: 2000 VacEx (Skid Mount Only)

GVWR; Dry Weight; Maximum Cargo Weight

2000 VacEx Skid Mount Only	Weight	Notes
GVWR		WARNING: DO NOT EXCEED GVWR
Machine Only (dry) (No Spoil, No Water)		
Maximum Cargo (Spoil* and Water)		

Tank Capacities

2000 VacEx Skid Mount Only	Capacity	Notes
Collection Tank	2000 gal (7575 L)	spoil weight varies by material type *
Fresh Water Tank(s)	500 gal (1900 L)	water weighs 8.35 lb/gal (1.00 kg/L)

* **IMPORTANT:** Spoil types range in density from approximately 9 lb/gallon (1.1 kg/L) to over 17 lb/gallon (2 kg/L). See "Spoil Density Chart" on page 88.

Antifreeze Dilution Chart

Freeze Point: Ice crystals begin to form

Burst Point: Fluid freezes solid and expands

Dilution	Freeze Point	Burst Point
50% water / 50% antifreeze	10°F (-12°C)	-50°F (-46°C)
60% water / 40% antifreeze	15°F (-9°C)	0°F (-18°C)
75% water / 25% antifreeze	21°F (-6°C)	15°F (-9°C)

Spoil Density Chart

- Water density is 8.35 lb/gal (1.00 kg/L)
- Water density with bentonite is approximately 8.6 lb/gal (1.03 kg/L)

MATERIAL	DENSITY (with estimated water added by excavation)							
	0-5% H ₂ O		25% H ₂ O		50% H ₂ O		75% H ₂ O	
	lb/ gal	kg/L	lb/ gal	kg/L	lb/ gal	kg/L	lb/ gal	kg/L
Caliche	12.00	1.44	11.10	1.33	10.20	1.22	9.20	1.10
Clay: wet excavated	15.20	1.82	13.50	1.62	11.80	1.41	10.00	1.20
Clay: wet lump	13.40	1.61	12.10	1.45	10.80	1.29	9.60	1.15
Earth: dense	16.70	2.00	14.60	1.75	12.50	1.50	10.40	1.25
Earth: loam, dry, excavated	10.40	1.25	9.90	1.19	9.40	1.13	8.80	1.05
Earth: moist, excavated	12.00	1.44	11.10	1.33	10.20	1.22	9.20	1.10
Earth: packed	12.70	1.52	11.60	1.39	10.50	1.26	9.40	1.13
Earth: soft loose mud	14.40	1.73	12.90	1.55	11.40	1.37	9.80	1.17
Earth: wet, excavated	13.40	1.61	12.10	1.45	10.80	1.29	9.60	1.15
Gravel: dry, 1/4-2"	14.00	1.68	12.60	1.51	11.20	1.34	9.70	1.16
Gravel: wet, 1/4-2"	16.70	2.00	14.60	1.75	12.50	1.50	10.40	1.25
Sand and Gravel: dry	14.40	1.73	12.90	1.55	11.40	1.37	9.80	1.17
Sand and Gravel: wet	16.70	2.00	14.60	1.75	12.50	1.50	10.40	1.25
Sand: dry	13.40	1.61	12.10	1.45	10.80	1.29	9.60	1.15
Sand: loose	12.00	1.44	11.10	1.33	10.20	1.22	9.20	1.10
Sand: rammed	14.00	1.68	12.60	1.51	11.20	1.34	9.70	1.16
Sand: wet	16.00	1.92	14.10	1.69	12.20	1.46	10.20	1.22
Sand: wet packed	17.40	2.08	15.10	1.81	12.80	1.53	10.6	1.27

Index

A

Antifreeze Dilution Chart, 88

B

Back-Pressure Cleaning, 62

Bag House Filters - Back-Pressure Cleaning, 62

Blower Protection, 50

Break-Away System Battery - Charge, 71

Break-Away System Battery - Test, 71

Break-Away System Cable - Inspect, 71

C

Call Your One-Call System Before Beginning Work, 45

Collection Tank - Clean Interior, 60

Control Panel (C), 17

D

Daily Engine Maintenance Chart, 69

Daily Inspection, 70

Daily Inspection and Maintenance, 49

Daily Machine Maintenance Chart, 69

Daily Maintenance, 47

Dealer Information, 79

Dealer Preparation, 77

Delivery to Customer, 78

Dump Collection Tank - Pressurized Unloading, 58

Dump Collection Tank - Rear Door Fully Open, 56

E

Electric Strike, 46

Engine Serial Number, 80

Exclusions of Warranties, 76

F

Fiber Optic Strike (Broken Line), 46

Freezing Conditions, 49

G

Gas Strike, 46

General Maintenance Information, 66

GVWR; Dry Weight; Maximum Cargo Weight, 83-87

H

High-Pressure Water, 66

Hitch Coupler Connections, 38

Hitch Coupler Separation, 40
Hourmeter, 66
Hydraulic Controls (H), 17

I

Identification Numbers - Record, 80
Initial Operational Settings, 47
Inspection, 66
Introduction, 2

J

K

L

Low Water Level Automatic Shutoff, 49
Lubricants, 66
Lubricants, 81

M

Machine - Inspection, Maintenance, and Initial Settings, 47
Machine - Location, 47
Machine Inspection, 47
Machine Preparation, 36
Machine Serial Number, 80
Machine Specifications, 82
Maintenance, 68
Maintenance Service Intervals and Procedures, 66
Modifications, 66

N

New Industrial Equipment Limited Warranty, 73

O

Operation - Excavating (Water and Vacuum), 54
Operation - Vacuum Only, 53
Operation - Water Only (High-Pressure), 52
Operational Settings - Initial, 51
Operator - Personal Protective Equipment, 44
Operator - Qualifications, 43
Operator - Training, 43
Original Owner Information, 79

P

Parts Warranty, 76
Photos and Illustrations, 67
Pintle Ring Connections, 39
Pintle Ring Separation, 41
Pre-Operation Information and Precautions, 49
Preparation - Machine, 47

Preparation - Operator, 43
Preparation - Operator, Worksite, and Machine, 49
Preparation - Worksite, 44
Primary Blower Protection - Primary Shutoff, 50

R

Report Safety Defects, 33
Retail Purchaser Responsibility, 73
Review of Operation, 78

S

Safety Shields, 67
Secondary Blower Protection - Bag House, 50
Section 1: Safety Messages, 7
Section 2: Intended Use, 15
Section 3: Component Identification, 17
Section 4: Starting Procedure, 27
Section 5: Shutdown Procedures, 29
Section 6: Transporting the Machine, 33
Section 7: Preparation, 43
Section 8: Operating the Machine, 49
Section 9: Daily Maintenance, 65
Section 10: Warranty, 73
Section 11: Receiving and Delivery, 77
Section 12: Specifications, 81
Severe Application, 67
Shutdown - Freezing Conditions, 30
Shutdown - Normal Conditions (Above Freezing), 29
Shutdown the Machine, 31
Specifications, 67
Specifications: 275 VacEx, 83
Specifications: 550 VacEx, 84
Specifications: 850 VacEx, 85
Specifications: 1300 VacEx, 86
Specifications: 2000 VacEx (Skid Mount Only), 87
Spoil Density Chart, 88
Starting - Freezing Conditions, 28
Starting - Machine Preparation, 27
Starting - Normal Conditions (Above Freezing), 27
Starting the Engine, 27
Storage - Tools and Hoses, 37
Storage and Start-Up Procedures, 67

T

Tank Capacities, 83-87
Tire and Load Information, 34
Tire Pressure and Lug Nuts - Check Daily, 72
Tires, 83-86

Tongue Weight, 35-86
Tools (T), 24
Towing Vehicle Selection, 35
Trailer Break-Away System Battery and Cable - Check Each Trip, 71
Trailer Height Adjustment, 37
Trailer/Towing Vehicle Disengagement , 40
Trailer/Towing Vehicle Engagement, 38
Transporting - Preparation, 36
Troubleshooting, 67

U

V

Vacuum Hose - Back-Pressure Cleaning, 62
Vacuum Hose - Wash Interior, 63
Vacuum System (V), 18

W

Warranty Terms, 73
Water System (W), 20
Weights (GVWR, Dry Weight, Maximum Cargo Weight), 35
Winterizing the Water System, 67
Winterizing the Water System (Option), 30
Worksite - Assessment, 44
Worksite - Evidence of Underground Utilities, 46
Worksite - Locate Buried Utilities, 45
Worksite - Utility Strike, 46

X

Y

Z

Copyright © 2012. All rights reserved.

Ring-O-Matic
P.O. Box 305 / 1714 Fifield Road
Pella, Iowa 50219
U.S.A.
800-544-2518 / 641-628-1515

Printed in the U.S.A.

\$39.95