



Operator's Manual

VO-452/455/460-MHI

Aerial Device

SERIAL NUMBER

39049-01

MANUAL PART NUMBER

 PLEASE NOTE THE ANSI A92.2 STANDARD AND THE MANUAL OF RESPONSIBILITIES CONTAINS RECENTLY UPDATED INFORMATION. DEALERS, OWNERS, USERS, OPERATORS, LESSORS AND LESSEES MUST ADHERE TO THESE UPDATED STANDARDS.

ATTENTION:

 **DO NOT ATTEMPT TO OPERATE THIS VERSALIFT UNTIL YOU HAVE READ AND UNDERSTOOD ALL INFORMATION IN BOTH OPERATOR'S AND SERVICE MANUALS, PROVIDED WITH EACH VERSALIFT.**

 **THIS MANUAL CONTAINS CONFIDENTIAL INFORMATION AND IS THE SOLE PROPERTY OF TIME MANUFACTURING CO. CONTENTS ARE NOT TO BE DISCLOSED, COPIED, OR REPRODUCED IN ANY MANNER WITHOUT THE EXPRESSED, WRITTEN PERMISSION OF TIME MANUFACTURING CO.**



Time Manufacturing Co. 7601 Imperial Drive P.O. Box 20368 Waco, Texas 76702 Phone: 254-399-2100 Fax: 254-751-0775

Time Manufacturing Co. reserves the right to improve the design or change specifications at any time without notice.



OWNER'S WARRANTY

The **Versalift** Aerial Platform Lift is engineered and designed to perform as stated on published specifications. Only quality material and workmanship are used in the manufacture of this product. With proper installation, regular maintenance, and periodic repair service, the equipment will provide excellent service.

Those parts of the **Versalift** that are manufactured by **Time Manufacturing Company** are warranted for one full year from date of purchase. Structural components will carry a lifetime warranty for defects in material and workmanship which existed at the time of initial delivery, wear components are not covered by this statement. This warranty is issued only to the original purchaser and promises that **Time Manufacturing Company** manufactured products are free from defects in material and factory workmanship when properly installed, serviced, and operated under normal conditions, according to the manufacturer's instructions.

Manufacturer's obligation under this warranty is limited to correcting without charge at its factory any part or parts thereof which shall be returned to its factory or one of its Authorized Service Stations, transportation charges prepaid, within one year after being put into service by the original user, and which upon examination shall disclose to the Manufacturer's satisfaction to have been originally defective. Correction of such defects by repair to, or supplying of replacements for defective parts, shall constitute fulfillment of all obligations to original user.

This warranty shall not apply to any of the Manufacturer's products which must be replaced because of normal wear, which have been subject to misuses, negligence or accident, or which shall have been repaired or altered outside of the Manufacturer's factory (unless authorized by the Manufacturer in writing), products which have not been maintained and operated in accordance with Time Manufacturing Company's operators, maintenance manuals and bulletins, products which are repaired without using original Time Manufacturing Company parts. This limited warranty does not cover transportation fees and/or consumables used for the repair. Products or parts manufactured by others are covered only by such warranties as are extended to TIME MANUFACTURING CO. by its suppliers.

Manufacturer shall not be liable for loss, damage, or expense directly or indirectly from the use of its product or from any cause.

The above warranty supersedes and is in lieu of all other warranties, expressed or implied, and of all other liabilities or obligations on part of Manufacturer. No person, agent, or dealer is authorized to give any warranties on behalf of the Manufacturer or to assume for the Manufacturer any other liability in connection with any of its products unless made in writing and signed by an officer of the Manufacturer.



TABLE OF CONTENTS

Introduction	Section 1
Manual Structure	1-1
Additional Manual Features	1-1
Nomenclature	1-2
Responsibilities / Safety	Section 2
Responsibilities of Dealers, Owners, Users, Operator, Lessors and Lessees	2-1
Decals	2-2
Think Safety	2-5
What is Insulated and What is not Insulated	2-8
Additional Safety Considerations	2-9
Specifications	Section 3
VO-452/455/460-MHI General Specifications	3-1
VO-452/455/460-MHI Option Specifications	3-2
VO-452/455/460-MHI Dimensional Specifications	3-5
VO-452/455/460-MHI Vehicle Specifications	3-9
Operation	Section 4
Positioning the Versalift for Operation	4-1
Aerial Lift Operations	4-2
Cab Control Operation	4-4
Ground Control Operation	4-4
Lower Control Operation	4-5
Upper Control Operation	4-7
Storing the Aerial Lift	4-9
Lifting Eye	4-10
Material Handling System	4-10
Emergency Operation	Section 5
Daily Visual Inspection	Section 6

INTRODUCTION

The **Versalift** aerial device has been designed and engineered to conveniently place personnel at work stations above the ground. This aerial device, as manufactured, meets or exceeds all applicable ANSI A92.2. Full controls at the platform and complete freedom of boom movements make the **Versalift** a truly flexible and functional work platform.

NOTE: As the aerial device users, you must read, understand, and follow the instructions in this manual and other manuals supplied with this aerial lift unit.

This manual is furnished to provide practical and essential information for efficient operation of the **Versalift** aerial device. Proper operation of this aerial lift is the responsibility of the operator and requires a thorough understanding of its capabilities. Personnel responsible for the operation of the aerial lift must be familiar with and understand this manual.

THIS MANUAL CONTAINS CONFIDENTIAL INFORMATION AND IS SOLE PROPERTY OF TIME MANUFACTURING, AND IS NOT TO BE DISCLOSED, COPIED, OR REPRODUCED WITHOUT EXPRESSED PERMISSION OF TIME MANUFACTURING.

In addition to, dealers, owners, operators, renters, lessors and lessees are required to comply with the requirements of the applicable section or sections found in ANSI A92.2.

NOTE: For additional safety information and required responsibilities, refer to the accompanying EMI Safety Manual and Manual of Responsibilities.

Detailed information for the maintenance inspection and service of the **Versalift** aerial device can be found in the accompanying Service Manual. Should further installation information be required, contact your local **Versalift** dealer or **Time Manufacturing Company**.

⚠ DANGER: THIS EQUIPMENT SHOULD BE OPERATED AND SERVICED ONLY BY COMPETENT PERSONNEL FAMILIAR WITH GOOD SAFETY PRACTICES. THIS INSTRUCTION IS WRITTEN FOR SUCH PERSONNEL AND IS NOT INTENDED AS A SUBSTITUTE FOR ADEQUATE TRAINING AND EXPERIENCE IN SAFE PROCEDURES FOR THIS TYPE OF EQUIPMENT.

⚠ DANGER: READ AND UNDERSTAND THIS MANUAL BEFORE ATTEMPTING TO OPERATE THIS AERIAL DEVICE.

The manual identifies all the controls and their locations and describes how the controls function.

Routine preventive maintenance is very important in maintaining reliable aerial lift service. A preventive maintenance schedule is provided and must be understood and followed by all operators.

⚠ DANGER: THIS IS NOT MAINTENANCE FREE EQUIPMENT.

NOTICE: THIS MANUAL IS A PERMANENT PART OF THE VERSALIFT AERIAL DEVICE AND MUST REMAIN WITH THE UNIT ALWAYS.

Time Manufacturing Company reserves the right to improve the design or specifications at any time without any obligation to incorporate new features into products previously sold.

MANUAL STRUCTURE

This manual is divided into six, numbered chapters. The first number in the page number at the bottom of each page identifies the chapter number. Chapter tabs, with titles printed on them, allow easy location of the desired subject.

ADDITIONAL MANUAL FEATURES

Danger, caution, and warning notes are indented, bold faced, and separated from the regular text to emphasize their importance and the need for attention.

English measurements are followed by equivalent metric measurements in parenthesis.

Non-critical units of measure are usually rounded-off to the nearest whole unit.

Notes referring the reader to related information in the manual indicate the chapter or a section of a chapter, not to a single page. The reader may need to scan a few pages to find the needed information.

REV.	ERCN NO.	DESCRIPTION	BY	CHKD.	APPR.	DATE
59541		FIRST RELEASE	LBR	DJH	SRS	10-12-11

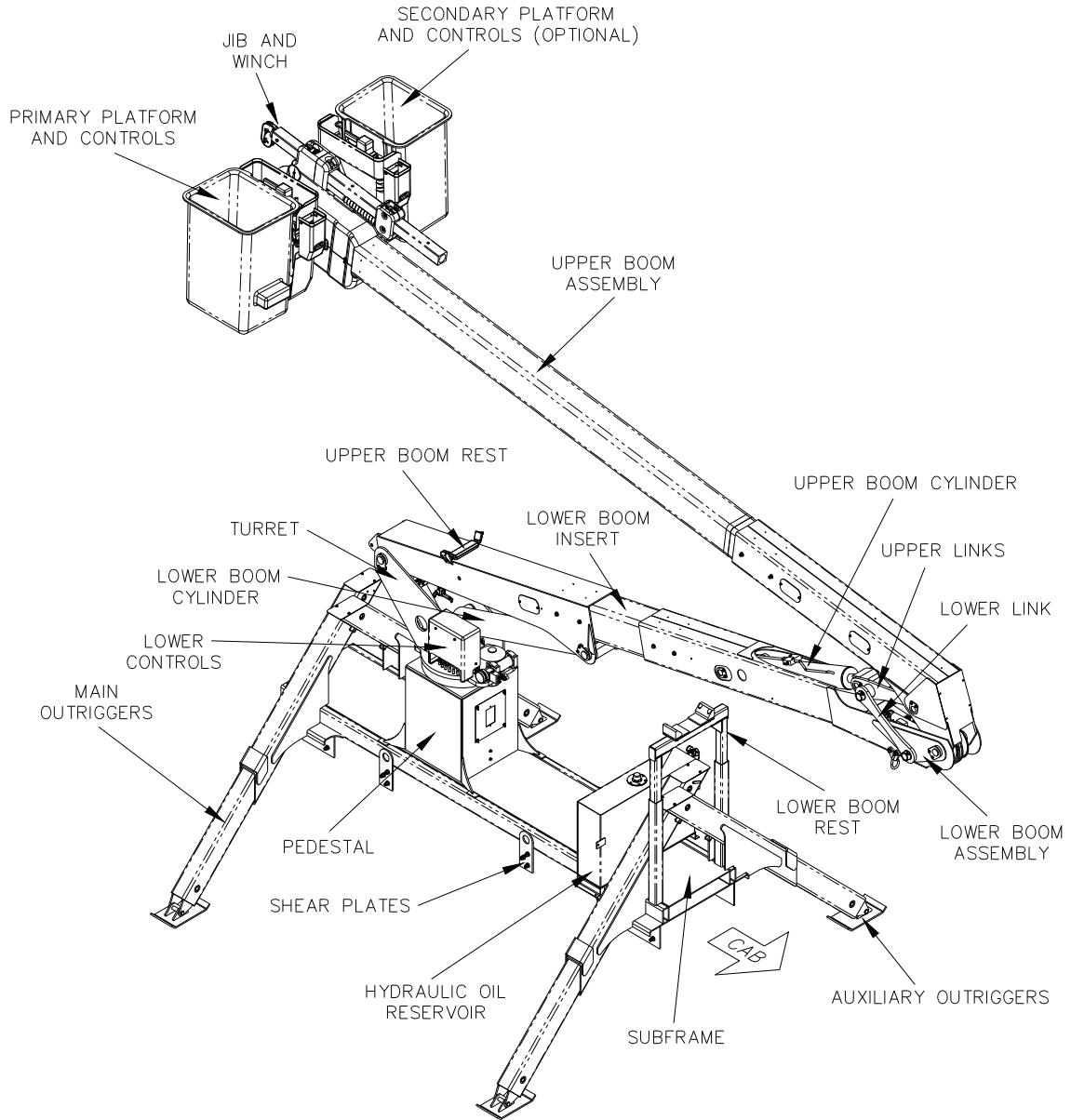

INTRODUCTION

UNLESS OTHERWISE NOTED:
 TOLERANCES: DECIMALS
 FRACTIONS ± 1/16 .X ± .1
 ANGLES ± 1' .XX ± .03
 .XXX ± .005

MACHINED SURFACE FINISHES = 125/
 PROJECTION OF VIEWS 
 ALL DIMENSIONS ARE IN INCHES

THIS PRINT CONTAINS CONFIDENTIAL INFORMATION AND IS SOLE PROPERTY OF TIME MANUFACTURING, AND IS NOT TO BE DISCLOSED, COPIED, OR REPRODUCED WITHOUT EXPRESSED PERMISSION OF TIME MANUFACTURING.

 MANUFACTURING COMPANY WACO TEXAS	DWN. BY	DATE	TITLE
	LBR	10-12-11	MAJOR COMPONENTS
MATERIAL	SIZE	SCALE	VO452/455/460MHI
FINISH	A	1=55	
	EST WT #	MANUAL	
		-	
	SHEET	DWG. NO.	
	1 OF 1	1000092-DWG	



RESPONSIBILITIES

(for Dealers, Owners, Users, Operator, Lessors and Lessees)

 **DANGER: FAILURE TO COMPLY WITH YOUR REQUIRED RESPONSIBILITIES IN THE USE AND OPERATION OF THE AERIAL DEVICE COULD RESULT IN DEATH OR SERIOUS INJURY.**

IMPORTANT

You are required by **ANSI/SIA A92.2** to read and understand **YOUR RESPONSIBILITIES** before you use or operate the Aerial Device. It is your responsibility and your employer's responsibility to identify and comply with applicable codes, standards, and regulations.

The operation of any aerial device is subject to certain **HAZARDS** that can be protected against only by the exercise of **INTELLIGENCE, CARE AND COMMON SENSE**. It is essential to have **COMPETENT, CAREFUL PERSONNEL, TRAINED** in the **INTENDED USE, SAFE OPERATION, MAINTENANCE AND SERVICE** of this type of equipment.

The **USER** and **OPERATOR MUST MAKE DECISIONS** on the maintenance, use and operation of the Aerial Device with due consideration for the fact that the **SAFETY OF THE OPERATOR AND OTHER PERSONNEL** is dependent on those decisions. **FAILURE TO COMPLY** with your **REQUIRED RESPONSIBILITIES** in the use and operation of the Aerial Device could result in **DEATH OR SERIOUS INJURY**.

 **DANGER: READ AND UNDERSTAND THIS MANUAL BEFORE ATTEMPTING TO OPERATE THIS AERIAL DEVICE.**

SAFETY

Only properly trained operators are qualified to operate the **Versalift** aerial lift. Operator training shall include complete instruction and understanding of the manufacturer's manuals, employer's work rules, and all related governmental regulations. Prior to operation from the platform the machine must be operating properly, must have been installed properly, inspected, and maintained in accordance with the manufacturer's instructions. All safety signs, guards, and covers must be in place and in proper condition.

! DANGER: AN UNTRAINED OR CARELESS OPERATOR SUBJECTS HIM/HERSELF AND OTHERS TO DEATH OR SERIOUS INJURY.

Throughout this manual there are **danger**, **warning**, and **caution** notes that emphasize the possible hazards when operating the **Versalift**. It is the responsibility of the operator to become familiar with the contents of this manual.

Two of the main risks associated with operating an aerial lift:

- (1) Electrocutation caused by operating too close to power lines.
- (2) Injuries caused by falling as a result of equipment failure or the operator performing an unsafe or unstable maneuver.

No manual can address every conceivable operating hazard. Therefore, the prevention of accidents is greatly dependent upon good judgement and common sense of the operator.

It is the responsibility of the operator to use the **Versalift** only when it has been installed and maintained in accordance with the manufacturer's manuals. The preventive maintenance program outlined in this manual and the Service manual must be followed.

It is extremely important for the operator to be thoroughly familiar with the **Versalift** aerial device. Study the information in this manual and the **Versalift** controls until both are completely mastered. Then go to a large, open area to practice using the aerial lift.

Decals are installed at numerous locations on the aerial lift to warn personnel of the potential hazards during the use and operation of the aerial lift. It is important that the operator and ground personnel read and understand the information on the decals. If any decals are defaced, illegible or lost, they must be replaced. Refer to the "Decal Placement" illustration

in this manual for a complete listing and the locations of the decals. For your convenience these decals are pictured on the following pages as a quick reference for reviewing safety concerns and for providing part numbers when ordering replacements.

DECALS

All the warning and instruction decals, and their respective part numbers, on the **Versalift** aerial device are included below and on the following pages. The decals are not shown at actual size.

VERSALIFT AERIAL DEVICE			
		Model <input type="text"/>	Serial number <input type="text"/>
TIME MANUFACTURING COMPANY PO BOX 20056 WACO, TEXAS 76702 www.versalift.com		Number of platforms <input type="text"/>	Electrical system voltage <input type="text"/> Vdc
Capacity per platform (See manual and decals for specific capacity) <input type="text"/>		Lbs <input type="text"/>	Kg <input type="text"/>
Platform height <input type="text"/>		FT <input type="text"/>	M <input type="text"/>
The boom is insulated <input type="checkbox"/> Yes <input type="checkbox"/> No	Hydraulic system operating pressure <input type="text"/>	Psi <input type="text"/>	Kg/Cm ² <input type="text"/>
Chassis insulating system <input type="checkbox"/> Yes <input type="checkbox"/> No	Dielectric category <input type="text"/>		
Equipped with high electrical resistance upper controls <input type="checkbox"/> Yes <input type="checkbox"/> No	Rated line voltage <input type="text"/>		
Configured for electrical work rubber gloving <input type="checkbox"/> Yes <input type="checkbox"/> No	Date of Qualification test <input type="text"/>		
Unit equipped for material handling <input type="checkbox"/> Yes <input type="checkbox"/> No	Date of Stability test <input type="text"/>		
Outriggers are required for stability <input type="checkbox"/> Yes <input type="checkbox"/> No	Installed by <input type="text"/>		
OPERATING INSTRUCTIONS Before operating this unit, read and understand all operating and safety information in manual and all information on this placard.			
<ol style="list-style-type: none"> 1. Always park vehicle as nearly level as possible. 2. When working on a slope, drive into or back into position. 3. Do not operate this unit on a slope without proper vehicle stability. Refer to the Operator's manual or fixed decals for stability requirements. 4. Inspect this device for visible defects or loose objects. 5. Inspect insulating boom and other insulating material for cleanliness, if applicable. 6. Set vehicle parking brake and chock wheels. 7. Engage hydraulic power source. 8. Extend outriggers, if so equipped, to a solid footing. 9. Raise booms sufficiently to clear obstructions on truck before rotating. 10. Operate all hydraulic controls smoothly and avoid quick reversal. 11. Inspect and service unit per instructions in Service and Installation Manual. 			
Ambient operating temperature range -40°F to 120°F (-40°C to 49°C)		This unit complies with ANSI A92.2 and CSA C225	

1006486-1 & 1006487-1 (DATA BACKING)

! NOTICE

RESPONSIBILITIES

- IT IS THE RESPONSIBILITY OF ANY USER OR OPERATOR OF THIS AERIAL DEVICE TO BECOME FAMILIAR WITH, AND TO COMPLY WITH, THE APPROPRIATE SECTION(S) OF THE AERIAL DEVICE STANDARD, ANSI A92.2.
- UPON TRANSFER OF OWNERSHIP IT SHALL BE THE RESPONSIBILITY OF THE SELLER TO PROVIDE THE MANUFACTURER'S MANUAL(S) FOR THAT AERIAL DEVICE TO THE PURCHASER.
- IT IS THE RESPONSIBILITY OF THE PURCHASER TO NOTIFY TIME MANUFACTURING, WACO, TEXAS, OF THE UNIT MODEL AND SERIAL NUMBER AND THE NAME AND ADDRESS OF THE NEW OWNER WITHIN 60 DAYS OF PURCHASE.

(REFERENCE: ANSI 92.2) 12337-1
PER ANSI Z35.4

12337-1

! CAUTION

REFER TO SERVICE MANUAL
BEFORE ADJUSTING
SYSTEM RELIEF VALVE 7584-1
PER ANSI Z35.4-1991

7584-1

RESPONSIBILITIES / SAFETY



WARNING

Crush Hazard
Contact with moving outriggers can result in death or serious injury.

Do not operate outrigger controls unless all personnel are clear of outrigger path and contact point.

12941-1 PER ANSI Z358.4

12341-1

WARNING

Fall Hazard
Falling can result in death or serious injury.

Wear approved personnel fall protection equipment and attach lanyard to the anchor provided.
Read and understand operator's manual.

14074-1 PER ANSI Z358.4

14014-1

DANGER

Electrocution Hazard
Contact with lines or components at different potential will result in death or serious injury.

Maintain minimum approach distances and use appropriate PPE, tools, and work methods. Allow for boom, platform, electrical line and load line sway. All components above insulated section must be considered electrically connected. Never simultaneously contact platform controls, lines or components at different potentials.

4542-4 PER ANSI Z358.4

4542-4

WARNING

Crush Hazard
Contact with moving outriggers can result in death or serious injury.

Stay clear of moving outriggers.

4992-1 PER ANSI Z358.4

4992-1

DANGER

Electrocution / Fire Hazard
Contact with energized lines while using conductive tool hoses will result in death or serious injury.

Use only orange, non-conductive hose for tools, in the platform area and insulated sections.
Read and understand operator's manual.

12340-1 PER ANSI Z358.4

12340-1

DANGER

Electrocution Hazard
THIS PLATFORM IS NOT INSULATED. Contact with or inadequate clearance to electrical power lines will result in death or serious injury.

1. Install insulating liner in basket.
2. Perform work in accordance with applicable governmental regulations.

14110-1 PER ANSI Z358.4

14110-1

WARNING

Improper operation or maintenance of this equipment can result in death or serious injury.

Read and understand operator's manual, all safety signs, and capacity charts before using or maintaining machine. If you do not understand the information in the manuals, consult your supervisor, the owner or the manufacturer. It is the user's responsibility to follow manufacturer's instructions on machine operation, service and application, and observe pertinent laws and regulations.

4542-12 PER ANSI Z358.4

4542-12

CAUTION

SLOWLY LOOSEN BLEED PORT PLUG TO LOWER BOOM. OIL WILL DISCHARGE FROM PLUG. DO NOT REMOVE PLUG! LOOSEN "BASE" PORT PLUG TO RETRACT. LOOSEN "ROD" PORT PLUG TO EXTEND. TIGHTEN PLUG AS DESCRIBED IN SERVICE MANUAL PRIOR TO OPERATION.

15732-1 PER ANSI Z535.4-1991

15732-1

DANGER

FAILURE TO OBEY THE FOLLOWING WILL RESULT IN DEATH OR SERIOUS INJURY

- FOR STATIONARY OPERATION, TRUCK MUST BE SECURELY PARKED, DRIVELINE DISENGAGED, AND AERIAL DEVICE PROPERLY STABILIZED PRIOR TO OPERATION.
- TO AVOID TIP-OVER, OUTRIGGERS (WHEN SO EQUIPPED) MUST BE PROPERLY EXTENDED TO A SOLID LEVEL SURFACE.
- OPERATE ALL CONTROLS SLOWLY FOR A SMOOTH PLATFORM MOTION. MAKE SURE CONTROLS ARE RETURNED TO NEUTRAL AFTER DESIRED OPERATION.
- CREW MUST USE PROPER PERSONAL AND OTHER PROTECTIVE EQUIPMENT.
- NEVER LOAD BEYOND RATED CAPACITY.
- NEVER OPERATE AERIAL DEVICE WITH PERSONNEL UNDER BOOM OR LOAD.
- NEVER MOVE THE TRUCK UNTIL THE BOOMS AND OUTRIGGERS ARE PROPERLY STOWED AND SECURED.
- REFER TO THE OPERATOR'S MANUAL FOR COMPLETE INSTRUCTIONS. IF IT IS MISSING, OBTAIN A NEW ONE FROM TIME MANUFACTURING, P.O. BOX 20368, WACO, TX., 76702

4542-5 PER ANSI Z535.4-1991

4542-5



⚠ DANGER

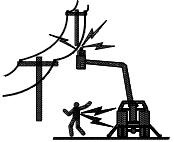

Electrocution Hazard
This equipment may be energized during operation. Contact with energized vehicle will result in death or serious injury.

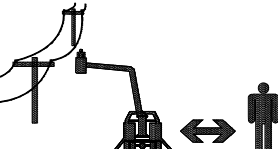

STAY CLEAR of machine.

4542-2

⚠ DANGER

IMPROPER HOLDING VALVE ADJUSTMENT WILL RESULT IN DEATH OR SERIOUS INJURY

1. LOOSENING HOLDING VALVE WITH BOOMS ELEVATED WILL CAUSE UNCONTROLLED BOOM MOVEMENT, DEATH OR SERIOUS INJURY MAY OCCUR.
2. REFER TO SERVICE MANUAL BEFORE PERFORMING HOLDING VALVE MAINTENANCE.

7500-1
PER ANSI Z535.4-1991

7500-1

⚠ DANGER



Crushing Hazard
Boom latch may move at any time.
Moving boom latch can cause serious injury.
Keep hands and fingers clear of boom latch.

20719-1
PER ANSI Z535.4

20719-1

⚠ DANGER



Electrocution Hazard
Death or serious injury may result if chassis becomes energized.
Do not operate the aerial device while creating a path to the ground.

35409-1
PER ANSI Z535.4

35409-1

⚠ DANGER

THE TOTAL LOAD IN THIS PLATFORM MUST NOT EXCEED _____ INCLUDING MAN, TOOLS, LINER, AND MATERIALS. EXCESS LOAD MAY CAUSE A FALL RESULTING IN DEATH OR SERIOUS INJURY.

14015-
PER ANSI Z535.4-1991

14015-

⚠ DANGER



- Do not depend on the jib pole for insulation unless the jib has been rated, tested, and maintained for the appropriate line voltage. The winch rope is NOT considered insulating.
- Inspect the winch rope before each use for wear, cuts, or other damage. Replace the rope at the first sign of damage or deterioration.
- Avoid shock loads.
- Improper use of the jib and winch may result in death or serious injury.
- Refer to the Operator's Manual for more information on the safe and proper use of the jib and winch.

11446-1
PER ANSI Z535.4

11446-1

⚠ DANGER

ELECTROCUTION HAZARD
FAILURE TO OBEY THE FOLLOWING WILL RESULT IN DEATH OR SERIOUS INJURY

THE UPPER CONTROLS DO NOT PROVIDE PROTECTION IN THE EVENT OF ELECTRICAL CONTACT AND ARE NOT A SUBSTITUTE FOR MINIMUM APPROACH DISTANCES, COVER-UPS, RUBBER GLOVES AND OTHER PERSONAL PROTECTIVE EQUIPMENT.

33974-1
PER ANSI Z535.4-1991

33974-1

⚠ DANGER

FAILURE TO OBEY THE FOLLOWING WILL RESULT IN DEATH OR SERIOUS INJURY

AERIAL DEVICE MUST BE LEVELED WITHIN 2' OF HORIZONTAL PRIOR TO AERIAL OPERATION. OUTRIGGERS MUST BE DEPLOYED FOR STABILITY.

33656-3

33656-3

↑ INSULATED SECTION ↑

5098-1

RESPONSIBILITIES / SAFETY

A safe attitude is very important to you, the operator. Practice anticipating accidents and operating hazards. Then determine a corrective course of action to respond to the situation. This habit will sharpen your safety awareness, quicken your reaction time, and prevent many accidents.

THINK SAFETY

The following sketches illustrate some of the unsafe situations that might occur during the use or operation of the **Versalift**. Some of these safety problems are very basic and as a result are often taken for granted.

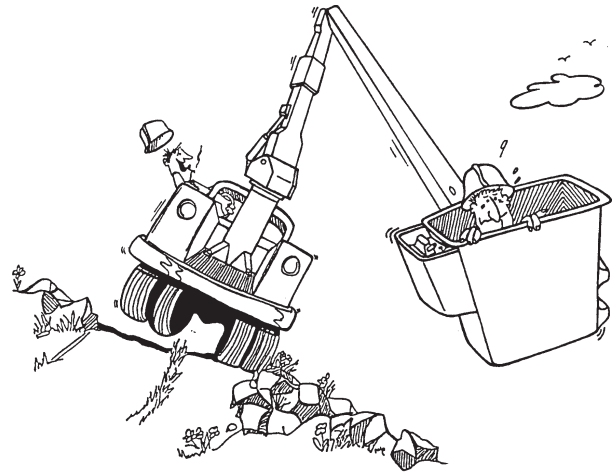

Don't park the truck on a hill unless absolutely necessary. When the truck is parked on a slope, take the special precautions defined in Chapter 4, "Operation".

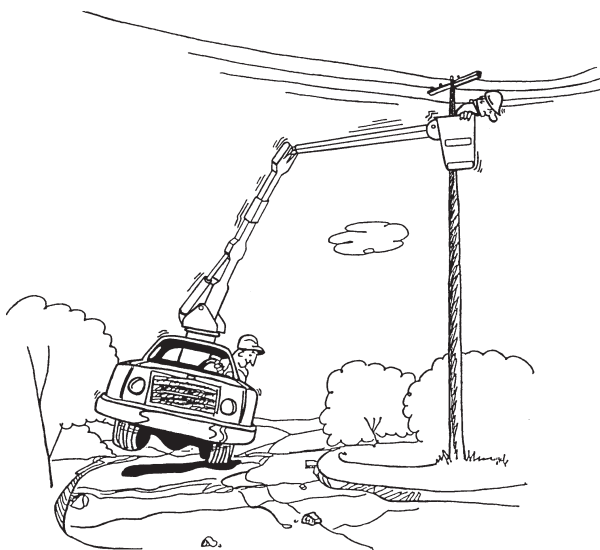

Always engage the outriggers, and maintain the correct tire pressure to increase vehicle stability.

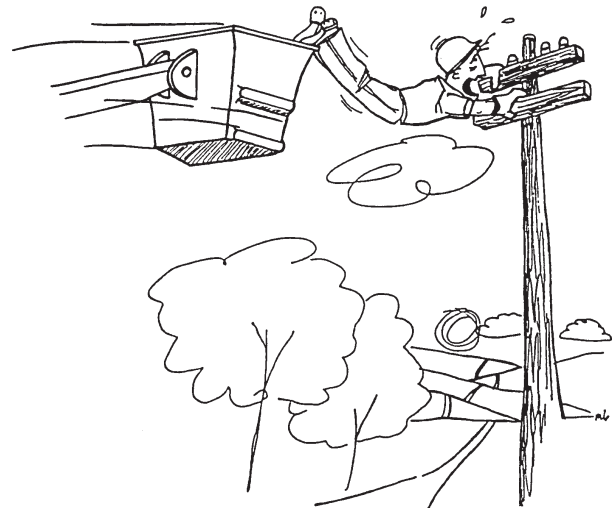

Remember to set the parking brake and chock the truck's wheels.



Always wear a personnel restraint system attached to the lanyard anchor.

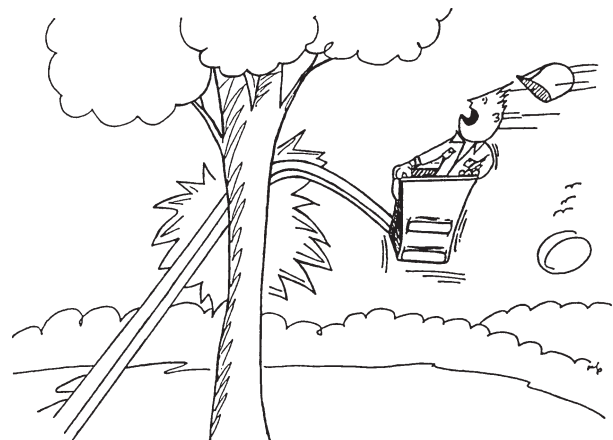

Watch the booms to make sure they clear the truck and other obstructions.

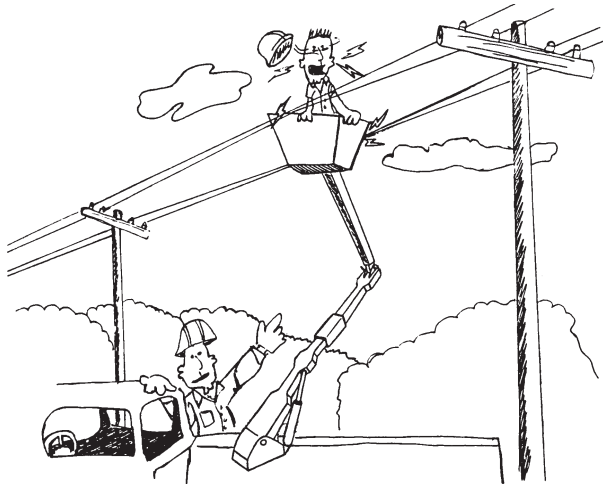

Maintain safe clearances from electrical power lines and apparatus. The aerial lift does not provide protection from contact or proximity to two or more electrically charged conductors.

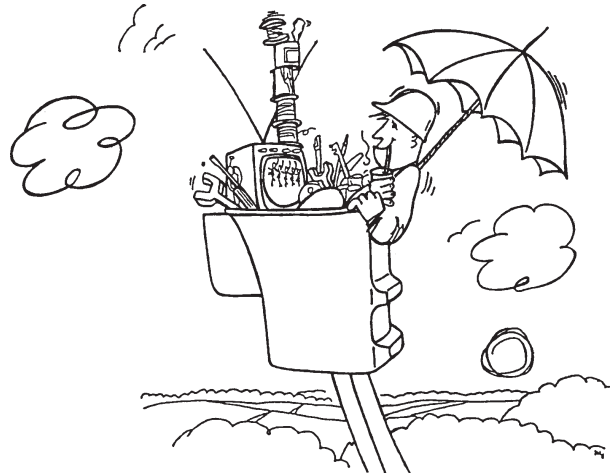

Whenever tools or equipment are included with the operator in the platform the combined weight must not exceed the rated load capacity.

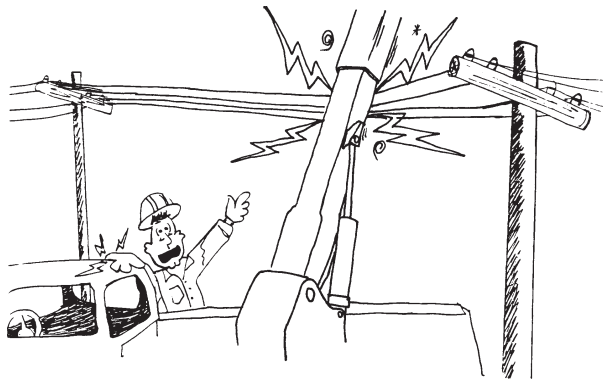

Never allow anyone on the ground to touch the unit when the lift is being used to work on or near electrical lines.

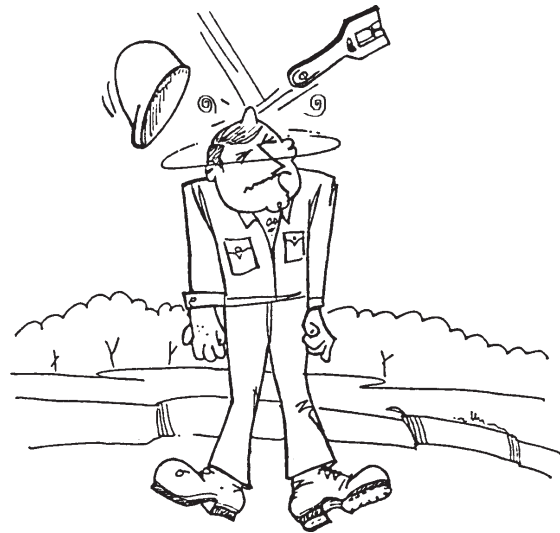

Avoid dropping tools. Use a hand line to raise or lower tools to/from the platform.

RESPONSIBILITIES / SAFETY

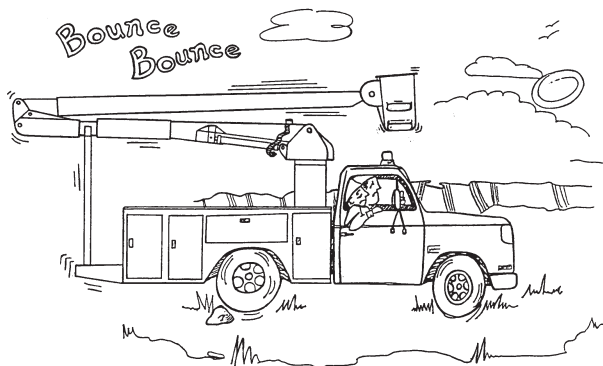

Stow the booms securely before moving the truck.

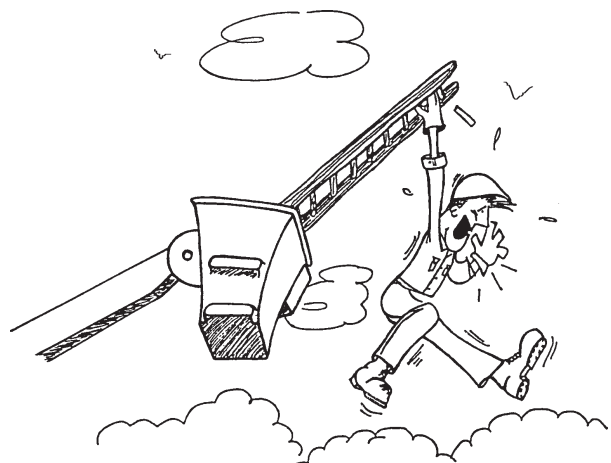

Stand only on the platform floor.



Don't climb out of a raised platform onto poles, etc.

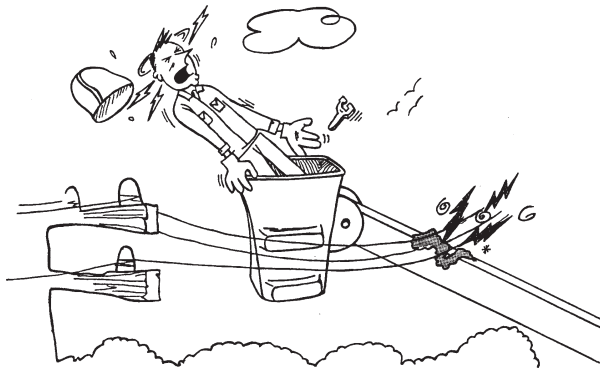

Keep the fiberglass booms clean and dry. Foreign substances on the booms conduct electricity.

What Is Insulated and What Is Not Insulated Articulated/Telescopic and Articulated Models

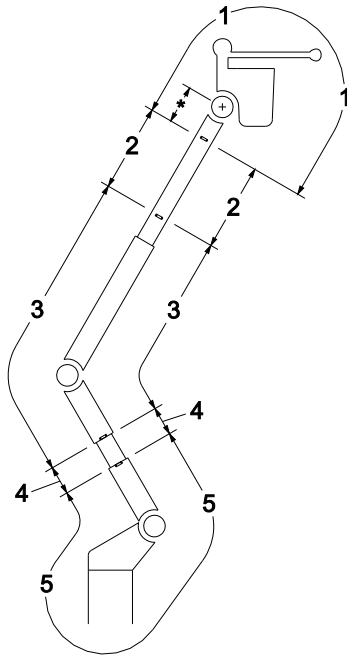

Area 1 - Boom Tip Area - NOT INSULATED

Area 2 - Upper Boom Insulating Section

Area 3 - Intermediate Structure - NOT INSULATED

Area 4 - Lower Boom Insulating Section

Area 5 - Lower Structure - NOT INSULATED

Area 1, Boom Tip Area – The boom tip area does not provide insulation. This area includes everything past the insulated section decal* on the upper boom. This includes the upper end of the boom, platform support, platform(s), controls, and the jib/winch/rope (when so equipped).

All components at the boom tip area must be considered to be conductive and electrically connected, even with an insulated liner in place. Any contact with a ground and a phase or between two phase conductors will create a hazard of serious personal injury or death. Contact between an energized conductor and any part of the boom tip will energize the entire boom tip.

When working near an energized conductor, ground conductor, or other grounded objects, the operator must use the proper safety equipment (such as rubber gloves, covers, hot sticks, etc.), maintain safe approach distances, and follow company work practices.

Area 2, Upper Boom Insulation Section – This section provides insulation** between the boom tip area and earth ground when clean and properly maintained. On some configurations, it is necessary to extend the boom until the insulated section decal is visible.

Area 3, Intermediate Structure – This section does not provide insulation. This area includes the lower steel portion of the upper boom, knuckle, and the

steel upper portion of the lower boom and compensation link (when applicable).

Area 4, Lower Boom Insulating Section – (When so equipped) This section provides insulation** between the intermediate structure (Area 3) and the vehicle when clean and properly maintained.

Area 5, Lower Structure – This area does not provide insulation. This area includes the steel lower portion of the lower boom and compensation link (when applicable), turret, lower controls, pedestal, and the vehicle.

* On VST and T-Series models not supplied with an upper insulated section decal, the insulated section begins 11 inches below the center of the platform pivot.

** Insulation properties are defined by ANSI A92.2

ADDITIONAL SAFETY CONSIDERATIONS

1. Report any unusual occurrence during the operation of the aerial lift that may require repair or adjustment by the service department.
2. Keep the work space in the truck bed clean and neat.
3. Avoid parking on soft surfaces. Soft surfaces may suddenly collapse, shift, or sink beneath the truck's weight.
4. There is no insulating value in the fiberglass platform without a platform liner.
5. No attempt should be made to clean, oil, or adjust a machine while the machine is in motion.
6. If the aerial lift has set idle for an extended period (i.e. overnight) or has been recently serviced, then cycle the lift through its full range of motion several times. This procedure will force any trapped air out of the hydraulic system. Do not operate the lift from the platform until this process is completed. Air trapped in the hydraulic oil can cause lift movements to be erratic and unpredictable.
7. Don't operate any part of the aerial lift (platform, booms, outriggers, etc.) outside the work site barricades into the traffic lanes. Set up adequate cones or barricades to mark the boundaries of the work site to alert motorists and pedestrians.
8. Only qualified mechanics are authorized to service the aerial lift.
9. The polyester winch rope is not an insulator. Dirt, grease, and moisture (humidity) make the rope conductive.
10. Make a thorough check of the winch rope for abrasive wear, pulled strands, cuts, and other defects daily.
11. Replace the winch rope at the first sign of damage or deterioration. Use only non-conductive rope of the size and type specified.
12. Avoid shock loads. A shock load is caused by jerking a line with a load or a sudden change in rope tension from a light load to a heavy load.
13. Do not contact energized conductors with the winch line. Contacting the load line with an energized conductor could create a complete path for electricity when the rope is extended to the ground. This could cause death or serious injury.
14. Avoid using the winch line to wrap or tie an object for lifting. The hook attached to the end of the winch line can damage or cut the rope. A sling or lifting strap is recommended for this purpose.
15. Do not stand in line with a rope under tension. If the rope should fail the recoil could cause serious injury to personnel.
16. Inspect the jib-pole assembly to make sure the various lock pins are secure.
17. Make sure the winch-rope coils are spooling evenly to avoid clogging the winch or producing shock loads when lifting a load.
18. Avoid contacting a spray or mist produced by a high pressure hydraulic leak. This spray or mist can puncture or become embedded beneath the skin or contaminate the eyes. These conditions require immediate medical attention.
19. Hydraulic oil is flammable. Avoid any contact between hydraulic oil and sources of high heat or open flames.
20. Bodily contact with hot hydraulic oil can cause serious burns which require immediate medical attention.

SPECIFICATIONS

VO-452/455/460-MHI GENERAL SPECIFICATIONS

Note: *Specifications on units may vary or change without prior notifications due to option selections.*

This section includes a brief description of each of the major (standard) components

PLATFORM CONTROLS - Includes a 3-Axis single handle controller with safety trigger, a locking lever for platform tilt, and controls for emergency stop, platform stow/unstow, platform rotation, and jib/winch operation. Also includes dual hydraulic tools with a 2000 psi reducing valve. Control valves are full pressure, full flow, manual type valves.

PLATFORM CONFIGURATIONS

- **SINGLE 1-MAN PLATFORM** – One single person, curbside mounted fiberglass platform (24" x 30" x 42" nominal size), with one inside and outside step. Includes two lanyard attachment points, 90° hydraulic rotation, and a tubular rubber platform rest. The standard platform capacity is 400 lbs (180 kg).
- **SINGLE 2-MAN PLATFORM** – One two-person, curbside mounted fiberglass platform (24" x 48" x 42" nominal size), with one inside and outside step. Includes two lanyard attachment points, 90° hydraulic rotation, and a tubular rubber platform rest. The standard platform capacity is 700 lbs (318 kg) on the VO-452 and VO-455. The standard platform capacity is 500 lbs (227 kg) on the VO-460.
- **DUAL 1-MAN PLATFORMS** – Two single person, side mounted fiberglass platforms (24" x 30" x 42" nominal size), each with one inside and outside step. Includes two lanyard attachment points, 90° hydraulic rotation for each platform, and a tubular rubber platform rest for each platform. The standard platform capacity is 350 lbs (160 kg) for each platform. Dual platforms are not available on the VO-460.

PERSONNEL RESTRAINT - A safety belt or harness and a lanyard are required and can be supplied by Time Manufacturing Company at an additional cost. Consult applicable work practices and regulations to choose between a safety belt and a harness.

AUTOMATIC PLATFORM LEVELING – The platform is automatically leveled throughout the entire boom working range. In the upper boom this accomplished by an enclosed parallelogram mechanical system. The major components of this system are 3/4" (19 mm)

diameter fiberglass rods, and ANSI #120 roller chain. The fiberglass rods maintain the insulation gap in all boom positions and are 100% tested at twice the rated load. In the lower boom the leveling is accomplished by a hydraulic master-slave arrangement. This system consists of a double acting hydraulic slave cylinder driven by a double acting hydraulic master cylinder. The system includes holding valves to lock the leveling in case of a hose failure and a relief valve to limit leveling system pressure.

HYDRAULIC PLATFORM TILT – A lever at the platform tilts the platform for rescue or clean-out. This is accomplished by overriding the slave hydraulic cylinder, which drives the mechanical leveling system. A control lever at the lower control station (turret) is optional.

MANUAL EXTEND HYDRAULIC TILT 5 FT JIB AND WINCH - The material handling jib pole hydraulically articulates from +90° to -35°, and the pole manually extends to 60" (1.5 m) in two 18" (46 cm) increments. A self-locking worm gearbox hydraulically powers the winch, which is rated at 2000 lbs (905 kg) full drum and includes 75' (22.9 m) of 9/16" (14mm) diameter polyester rope with clevis hook. A control valve for the winch is provided at both the upper and lower controls.

UPPER BOOM – Constructed from 10.5" x 12.5" (27 cm x 32 cm) rectangular high strength filament wound epoxy resin fiberglass which is bonded and bolted to steel weldments at each end. The fiberglass section has a gel coat and high gloss urethane finish for added weather protection and water beading. The upper boom is articulated 195° by one double acting cylinder with two holding valves through a mechanical linkage. An upper boom storage cradle mounted on the lower boom assures solid boom support in the stowed position. A ratchet-type boom tie-down strap is included.

LOWER BOOM (VO-452) – Constructed from 12" x 14" (30 cm x 35 cm) cross-section high strength steel and a filament wound, high strength, epoxy resin fiberglass insert. The fiberglass insert provides a 12" (30 cm) insulation gap.

LOWER BOOM (VO-455, VO-460) – Constructed from 12" x 14" (30 cm x 35 cm) cross-section high strength steel and a filament wound, high strength, epoxy resin fiberglass insert. The fiberglass insert provides a 24" (60 cm) insulation gap.

BOOM CYLINDERS – The upper and lower booms are each powered by a double acting cylinder equipped with two integral holding valves. The rod eyes for both cylinders are attached by threading and welding. Both



cylinders are fully retracted when stowed, protecting the rod from damage and rust.

TURRET – Fixture welded steel structure is constructed from 3/4" (19 mm) thick plate wings and a 1.5" (38 mm) thick base plate. The base plate is machined flat to support the rotation bearing and gearbox.

LOWER CONTROLS – Consists of individual control levers mounted on the turret which actuate the lower boom, upper boom, rotation, and winch. The lower controls also include an upper control over-ride/e-stop. The lower control valve is a full pressure, full flow manual type valve.

CONTINUOUS ROTATION - Rotation is continuous and unrestricted in either direction. The rotation system consists of a hydraulically driven worm and spur gear acting on a shear-ball rotation bearing. The critical bolts holding the lift to the rotation bearing and the rotation bearing to the pedestal are grade 8. These critical bolts are torque seal marked to provide a quick means of detecting any loosening. An eccentric ring gearbox mounting allows for precise backlash adjustments.

PINS, BEARINGS, AND LUBRICATION – Pivot pins are made from high strength hard chrome plated steel with fiberglass reinforced Teflon non-lube bearings. Only the rotation bearing and leveling chains require lubrication.

34 IN TALL PEDESTAL - The pedestal is a fabricated steel structure incorporating a 1.5" (38 mm) thick top plate which is machined flat to support the rotation bearing. (The 34 in (0.86 m) height refers to the installed height, measured from the top of the chassis frame to the top of the pedestal.)

HYDRAULIC SYSTEM - The open center hydraulic system operates at 3000 PSI (210 kg/cm²) and provides up to 8 GPM (30 LPM). With the optional manual or automatic throttle control, the system provides up to 8 GPM (30 LPM) at engine idle and 12 GPM (45 LPM) with the throttle advanced.

OIL RESERVOIR – 30 gallon bulkhead mount reservoir. Includes cleanout, 10 micron return filter that can be replaced without draining the reservoir, filter gauge, 100 mesh (149 micron) suction screen, gate valve, and magnetic drain plug.

ENGINE START/STOP CONTROL - An air cylinder at the upper controls and a toggle switch at the lower controls operate the system.

HOSES AND FITTINGS - The high pressure hoses routed through the booms are non-conductive hoses with swaged hose end fittings. Retainers are used to separate the hoses inside the booms to prevent chafing and nylon sleeves are installed over hoses at points of movement. Reusable hose fittings can be installed if a hose is damaged.

ELECTRICAL INSULATION SPECIFICATIONS - The upper boom is tested and certified according to ANSI A92.2 Category C dielectric rating requirements. This allows the unit to be rated at the design voltage of 46kv and below. Aerial devices may be designed and configured for gloving work and tool methods at 46KV and below. The chassis insulating system (lower boom insert) is also tested and certified according to ANSI A92.2.

OUTRIGGER/BOOM INTERLOCK - The outrigger/boom interlock option is a feature designed to prevent the lift from being operated until the outriggers contact the ground. The interlock also prevents the outriggers from being retracted before the aerial lift is properly stored.

SLOPE INDICATORS - Slope indicators are required on Versalift units and supplied by Time Manufacturing Co. Slope indicators shall be installed to indicate the level of the rotation bearing relative to the ground.

PAINTING - The complete unit is primed and painted prior to assembly. The standard color is white urethane.

MANUALS - Two Operator's Manuals and two Service Manuals, one Manual of Responsibilities and one EMI Safety Manual are included with each aerial lift.

VO-452/455/460-MHI OPTION SPECIFICATIONS

This section contains a brief description of some of the numerous available options.

DUAL UPPER CONTROLS – Additional 3-axis single handle controller with safety trigger mounted between the street side platform and the boom. Available with dual platforms only.

TRUGUARD – This advanced upper controls isolation system provides 4" of electrical isolation from the entire upper controls, including the control dash panel. This system also includes a protective shield which helps prevent environmental and work related contaminants from making direct contact with the isolating surfaces.



THE UPPER CONTROLS DO NOT PROVIDE PROTECTION IN THE EVENT OF ELECTRICAL CONTACT AND ARE NOT A SUBSTITUTE FOR MINIMUM APPROACH DISTANCES, COVERS, RUBBER GLOVES AND OTHER PERSONAL PROTECTIVE EQUIPMENT.

INSULATED PLATFORM LINER - Liners are available for all standard sized platforms. The liners are tested and rated for 50 KV AC.

PLATFORM COVER - Soft vinyl covers are available to fit all standard sized platforms.

HYDRAULIC EXTEND HYDRAULIC TILT 5 FT JIB AND WINCH - The material handling jib pole hydraulically articulates from +90° to -35°, and the pole hydraulically extends to 60" (1.5 m) in two 18" (46 cm) increments. A self-locking worm gearbox hydraulically powers the winch, which is rated at 2000 lbs (905 kg) full drum and includes 75' (22.9 m) of 9/16" (14mm) diameter polyester rope with clevis hook. A control valve for the winch is provided at both the upper and lower controls.

MANUAL EXTEND HYDRAULIC TILT 6.5 FT JIB AND WINCH - The material handling jib pole hydraulically articulates from +90° to -35°, and the pole manually extends to 78" (2.0 m) in three 18" (46 cm) increments. A self-locking worm gearbox hydraulically powers the winch, which is rated at 2000 lbs (905 kg) full drum and includes 75' (22.9 m) of 9/16" (14mm) diameter polyester rope with clevis hook. A control valve for the winch is provided at both the upper and lower controls.

HYDRAULIC EXTEND HYDRAULIC TILT 6.5 FT JIB AND WINCH - The material handling jib pole hydraulically articulates from +90° to -35°, and the pole hydraulically extends to 78" (2.0 m) in three 18" (46 cm) increments. A self-locking worm gearbox hydraulically powers the winch, which is rated at 2000 lbs (905 kg) full drum and includes 75' (22.9 m) of 9/16" (14mm) diameter polyester rope with clevis hook. A control valve for the winch is provided at both the upper and lower controls.

LIFTING EYE ATTACHMENT - The lifting eye attachment is located near the elbow on the lower boom. The lifting eye has a maximum capacity of 2500 lbs (1100 kg).

MANUAL TWO SPEED THROTTLE – Advances the engine idle speed to provide efficient boom speeds. At engine idle, the system provides the desired flow for hydraulic tools. An air cylinder at the upper controls and a toggle switch at the lower controls operate the

system. This option requires the use of an additional pass in the collector ring assembly.

AUTOMATIC TWO SPEED THROTTLE – Automatically advances the engine idle speed when operating a boom function from the upper controls. At engine idle, the system provides the desired flow for hydraulic tools. When a lift function is engaged, the engine speed increases to provide efficient boom speeds. The system also includes a toggle switch to manually advance the throttle from the lower controls. This option requires the use of an additional pass in the collector ring assembly.

BACKUP PUMP - An auxiliary hydraulic pump designed to bring the booms down in case the main hydraulic source fails. This system consists of a hydraulic pump driven by a DC motor, which is powered by the truck's engine battery. The system is connected in parallel with the main pump and is designed for non-continuous operation. An air cylinder at the upper controls is used to energize this system. This option requires the use of an additional pass in the collector ring assembly.

CATEGORY B DIELECTRIC TESTING AND CERTIFICATION - Testing and certification for ANSI A92.2 Category B. Aerial devices may be designed and configured for gloving work provided it meets the requirements per ANSI A92.2 category B. This option includes a lower test electrode system (test bands) and vacuum prevention for all the hydraulic hoses routed through the insulated booms.

CATEGORY D DIELECTRIC TESTING AND CERTIFICATION - Testing and certification for ANSI A92.2 Category D are available. These aerial devices which are designed and manufactured for work in which the insulating system is not considered as primary insulation, but secondary. These aerial devices are NOT designed for gloving work methods. They are rated at voltages of 46kv.

LOWER BOOM STOW LIMIT – Consists of a hydraulic diverter and relief valve and is designed to limit the down-force of the lower boom cradle when stowed. This option is recommended when the lower boom is stowed above horizontal.

SUB-FRAME – The full length sub-frame is constructed of 3" x 6" (76 mm x 152 mm) rectangular tubing and 3/8" (10 mm) plate. Shear plates are provided to attach to the vehicle chassis.

40 IN TALL PEDESTAL - The pedestal is a fabricated steel structure incorporating a 1.5" (38 mm) thick top plate which is machined flat to support the rotation

bearing. (The 40 in (1.0 m) height refers to the installed height, measured from the top of the chassis frame to the top of the pedestal.) This pedestal may be trimmed at installation up to 6 in (15 cm) to obtain the desired travel height and cab clearance.

46 IN TALL PEDESTAL - The pedestal is a fabricated steel structure incorporating a 1.5" (38 mm) thick top plate which is machined flat to support the rotation bearing. (The 46 in (1.2 m) height refers to the installed height, measured from the top of the chassis frame to the top of the pedestal.) This pedestal may be trimmed at installation up to 6 in (15 cm) to obtain the desired travel height and cab clearance.

A-FRAME OUTRIGGERS - A-frame outriggers are designed and constructed from high-strength steel. The cross-beam is shipped loose to allow the desired ground clearance and penetration to be determined at installation. At maximum extension the outriggers provide 158" (4.0 m) of spread and from 6" to 11" (15 cm to 28 cm) of penetration based on a 40" (1.02 m) frame height. Outriggers are equipped with pilot operated check valves, internal thermal relief valves, and separate operating controls for each outrigger. Slide pads at each leg ensure smooth operation. The standard pivot feet swivel a minimum of 10° each way.

X-FRAME OUTRIGGERS, FLIP FOOT - X-frame outriggers are designed and constructed from high-strength steel. The mounting plates are shipped loose to allow the desired ground clearance and penetration to be determined at installation. At maximum extension the outriggers provide 176.5" (4.5 m) of spread and from 5" to 12" (13 cm to 30 cm) of penetration based on a 40" (1.02 m) frame height. Outriggers are equipped with pilot operated check valves, internal thermal relief valves, and separate operating controls for each outrigger. Slide pads at each leg ensure smooth operation. The standard pivot feet swivel a minimum of 10° each way.

RADIAL OUTRIGGERS - Radial outriggers are designed and constructed from high-strength steel. At 11" (28 cm) of penetration the outriggers provide 211" (5.4 m) of spread based on a 40" (1.02 m) frame height. Outriggers are equipped with pilot operated check valves, internal thermal relief valves, and separate operating controls for each outrigger.

AUTOMATIC BOOM LATCH – The automatic boom latch is designed to automatically restrain the upper boom in the cradle when stowed and automatically release the boom when the lift is operated. The latch is actuated by a hydraulic cylinder and includes a manual over-ride to open the latch without hydraulic power.

PLATFORM TILT AT LOWER CONTROLS – An additional lever at the lower control station operates the platform stow/unstow function.

PLATFORM ELEVATOR (Single Platform Only) – Hydraulically controlled platform elevator which will raise the platform and control panel 24" at the boom tip. Driven by a telescoping cylinder, the platform elevator can be raised proportionally using the same style control valve used for all boom function.

DIMENSIONAL SPECIFICATIONS

Note: All values are nominal.

ITEM	VO-452	VO-455	VO-460
Height to Bottom of Platform	52.7' (16.1 m)	55.7' (17.0 m)	60.7' (18.5 m)
Working Height	57.5' (17.5 m)	60.7' (18.5 m)	65.7' (20.0 m)
Horizontal Reach Overcenter	45.3' (13.8 m)	48.3' (14.7 m)	53.3' (16.2 m)
Horiz Reach Non-Overcenter 102°	34.2' (10.4 m)	36.0' (11.0 m)	39.0' (11.9 m)
Horiz Reach Non-Overcenter 110°	36.9' (11.2 m)	39.0' (11.9 m)	42.3' (12.9 m)
Horiz Reach Non-Overcenter 120°	40.2' (12.3 m)	42.5' (13.0 m)	46.2' (14.1 m)
Platform Capacity Single 1-Man	400 lbs (180 kg)	400 lbs (180 kg)	400 lbs (180 kg)
Platform Capacity Single 2-Man	700 lbs (318 kg)	700 lbs (318 kg)	500 lbs (227 kg)
Total Platform Capacity Dual 1-Man	700 lbs (318 kg)	700 lbs (318 kg)	Not available
Total Platform Capacity Dual 1-Man With Dual Controls	700 lbs (318 kg)	700 lbs (318 kg)	Not available
Upper Boom Articulation	195°		
Lower Boom Articulation	102°, 110°, or 120°		
Stowed Travel Height	11.5' (3.5 m)		
Maximum Jib Capacity	2000 lbs (900 kg)		
Lower Boom Lift Eye Capacity	2500 lbs (1100 kg)		
Hydraulic System Pressure	3000 psi (210 kg/cm ²)		
Hydraulic System Type	Open Center		
Upper Boom Insulation Gap	13.2' (4.0 m)	13.2' (4.0 m)	15.7' (4.8 m)
Lower Boom Insulation Gap	12" (30 cm)	24" (60 cm)	24" (60 cm)
Approximate Weight of Lift with Pedestal	6900 lbs (3150 kg)	7000 lbs (3200 kg)	7200 lbs (3300 kg)
Ambient Temperature Range for Structural Integrity	-40°F (-40°C) to 125°F (52°C)		

Notes:

1. All height dimensions are based on a 40" (1.02 m) chassis frame height and a standard 36" (0.91 m) tall pedestal. Add 6" (15 cm) for the 40" (1.02 m) pedestal. Add 12" (30 cm) for the 46" (1.17 m) pedestal.
2. Actual travel height will vary with frame height, cab height, pedestal height, mounting location, etc.

REV	ERCN NO.	DESCRIPTION	BY	CHKD.	APPR.	DATE
1	59541	FIRST RELEASE	LBR	DJH	SRS	10-12-11

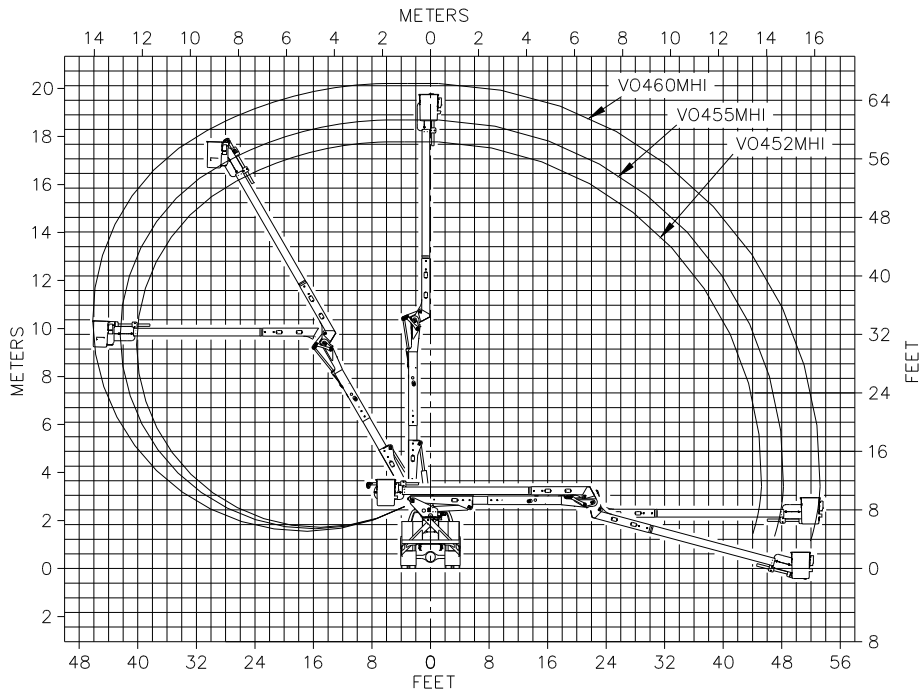

**120° LOWER BOOM
ARTICULATION**

UNLESS OTHERWISE NOTED:
 TOLERANCES: FRACTIONS ± 1/16 DECIMALS
 ANGLES ± .1° .1° .1° .1° .1° .1°
 MACHINED SURFACE FINISHES = 125
 PROJECTION OF VIEWS = 1ST ANGLE
 ALL DIMENSIONS ARE IN INCHES
 THIS PRINT CONTAINS CONFIDENTIAL INFORMATION AND IS SOLE PROPERTY OF TIME MANUFACTURING, AND IS NOT TO BE DISCLOSED, COPIED, OR REPRODUCED WITHOUT EXPRESSED PERMISSION OF TIME MANUFACTURING.

	MANUFACTURING COMPANY	DWN. BY	DATE	TITLE
	WACO TEXAS	LBR	10-12-11	REACH DIAGRAM
MATERIAL		SIZE	SCALE	VO452/455/460MHI
FINISH		A	1=200	
		EST WT #	MANUAL	
		SHEET	DWG. NO.	
		1 OF 3	1000082-DWG	

SPECIFICATIONS

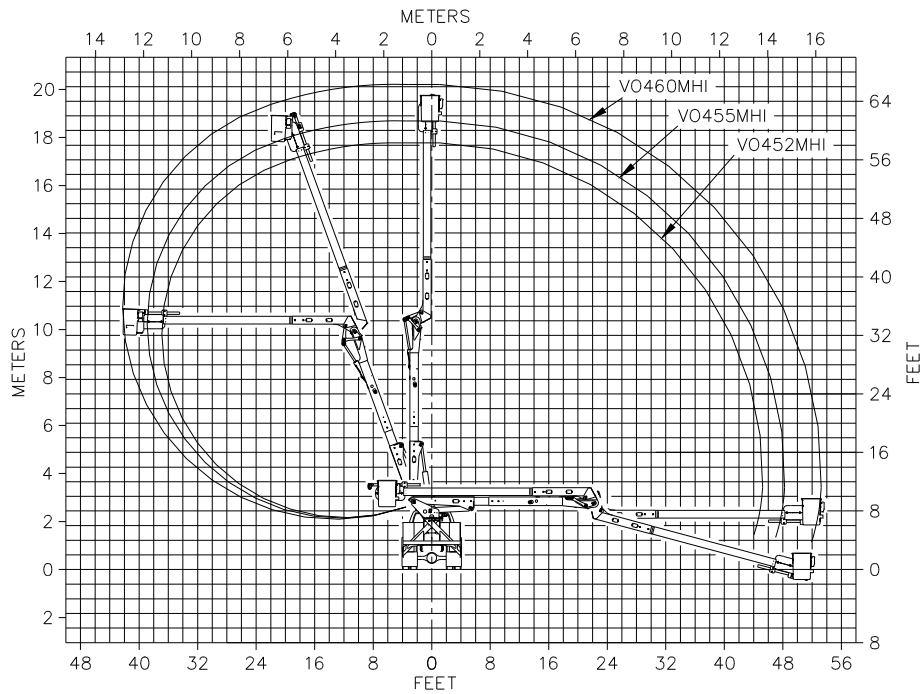

**110° LOWER BOOM
ARTICULATION**

UNLESS OTHERWISE NOTED:
 TOLERANCES: FRACTIONS ± 1/16 DECIMALS
 ANGLES ± .1° .1° .1° .1° .1° .1°
 MACHINED SURFACE FINISHES = 125
 PROJECTION OF VIEWS = 1ST ANGLE
 ALL DIMENSIONS ARE IN INCHES
 THIS PRINT CONTAINS CONFIDENTIAL INFORMATION AND IS SOLE PROPERTY OF TIME MANUFACTURING, AND IS NOT TO BE DISCLOSED, COPIED, OR REPRODUCED WITHOUT EXPRESSED PERMISSION OF TIME MANUFACTURING.

	MANUFACTURING COMPANY	DWN. BY	DATE	TITLE
	WACO TEXAS	LBR	10-12-11	REACH DIAGRAM
MATERIAL		SIZE	SCALE	VO452/455/460MHI
FINISH		A	1=200	
		EST WT #	MANUAL	
		SHEET	DWG. NO.	
		2 OF 3	1000082-DWG	



REV.

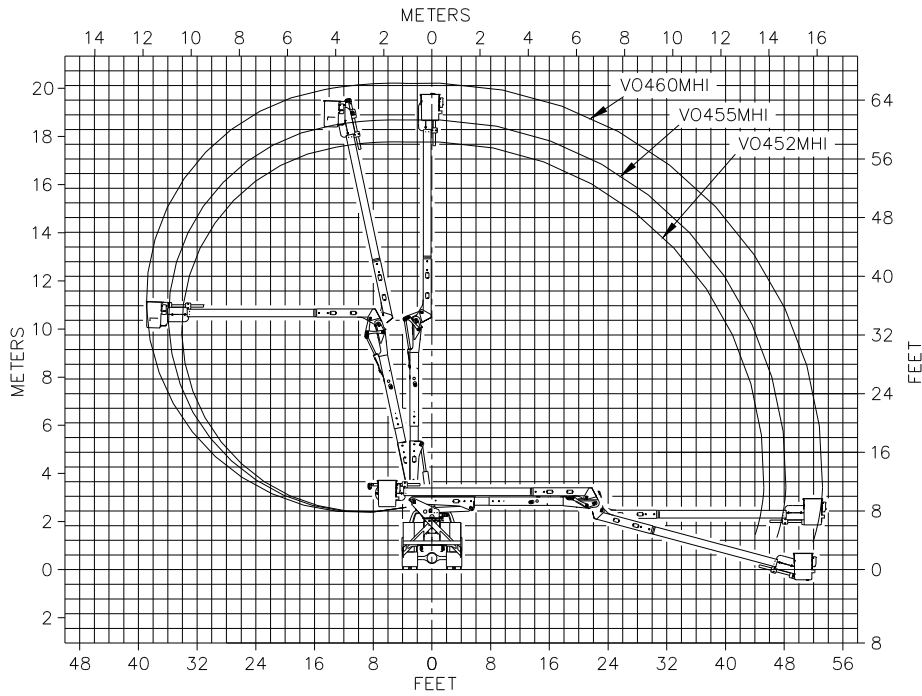

**102° LOWER BOOM
 ARTICULATION**

UNLESS OTHERWISE NOTED:
 TOLERANCES: DECIMALS ± .01
 FRACTIONS ± 1/16
 ANGLES ± 1' XX ± .03
 XXX ± .005
 MACHINED SURFACE FINISHES: .125/
 PROJECTION OF VIEWS:
 ALL DIMENSIONS ARE IN INCHES
 THIS PRINT CONTAINS CONFIDENTIAL
 INFORMATION AND IS SOLE PROPERTY
 OF TIME MANUFACTURING, AND IS NOT
 TO BE DISCLOSED, COPIED, OR
 REPRODUCED WITHOUT EXPRESSED
 PERMISSION OF TIME MANUFACTURING.

**MANUFACTURING
 COMPANY**
 WACO TEXAS

MATERIAL
 FINISH

DWN. BY	DATE	TITLE
LBR	10-12-11	REACH DIAGRAM
SIZE	SCALE	VO452/455/460MHI
A	1=200	
EST WT #	MANUAL	
SHEET	DWG. NO.	
3 OF 3	1000082-DWG	

SPECIFICATIONS



REV	CRWN NO	DESCRIPTION	BY	CHKD	APPR	DATE
59541		FIRST RELEASE	LBR	DJH	SRS	10-12-11

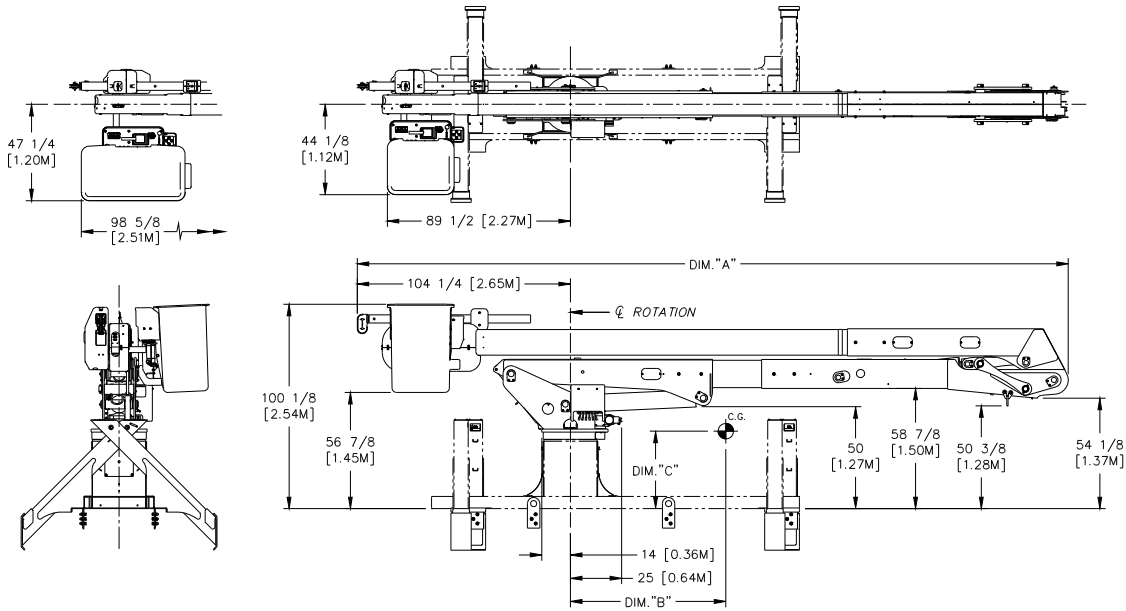

SINGLE PLATFORM MODELS

MODEL	DIM. "A"	APPROX. DIM. "B"	APPROX. DIM. "C"	APPROX. WEIGHT
VO452MHI	330 [8.38M]	53	59	6700 LBS.
VO455MHI	348 [8.84M]	60	59	6800 LBS.
VO460MHI	378 [9.60M]	70	59	7000 LBS.

- NOTES:
 1.) 34" STD. PEDESTAL IS SHOWN.
 2.) WEIGHTS DO NOT INCLUDE SUBFRAME, OUTRIGGERS OR MOUNTING HARDWARE.
 3.) DIMENSIONS ARE IN INCHES [METERS].
 4.) THE SUBFRAME WEIGHT IS APPROX. 10 LBS. PER INCH.
 5.) APPROXIMATE OUTRIGGER WEIGHTS:
 A-FRAME.....1150 LBS.
 X-FRAME.....1400 LBS.
 RADIAL.....1600 LBS.

<small>UNLESS OTHERWISE NOTED: TOLERANCES: FRACTIONS ± 1/16 X ± 1.3 ANGLES ± 1' XX ± 0.05 MACHINED SURFACE FINISHES = 125 PROJECTION OF VIEWS = 1 ALL DIMENSIONS ARE IN INCHES THIS PRINT CONTAINS CONFIDENTIAL INFORMATION AND IS SOLE PROPERTY OF TIME MANUFACTURING, AND IS NOT TO BE DISCLOSED, COPIED, OR REPRODUCED WITHOUT EXPRESSED PERMISSION OF TIME MANUFACTURING.</small>		DWN. BY	DATE	TITLE
		LBR	10-12-11	VO452/455/460 MHI OVERALL
MATERIAL		EST WT #	MANUAL	
FINISH		SHEET	1 OF 2	DWG. NO. 1000084-DWG

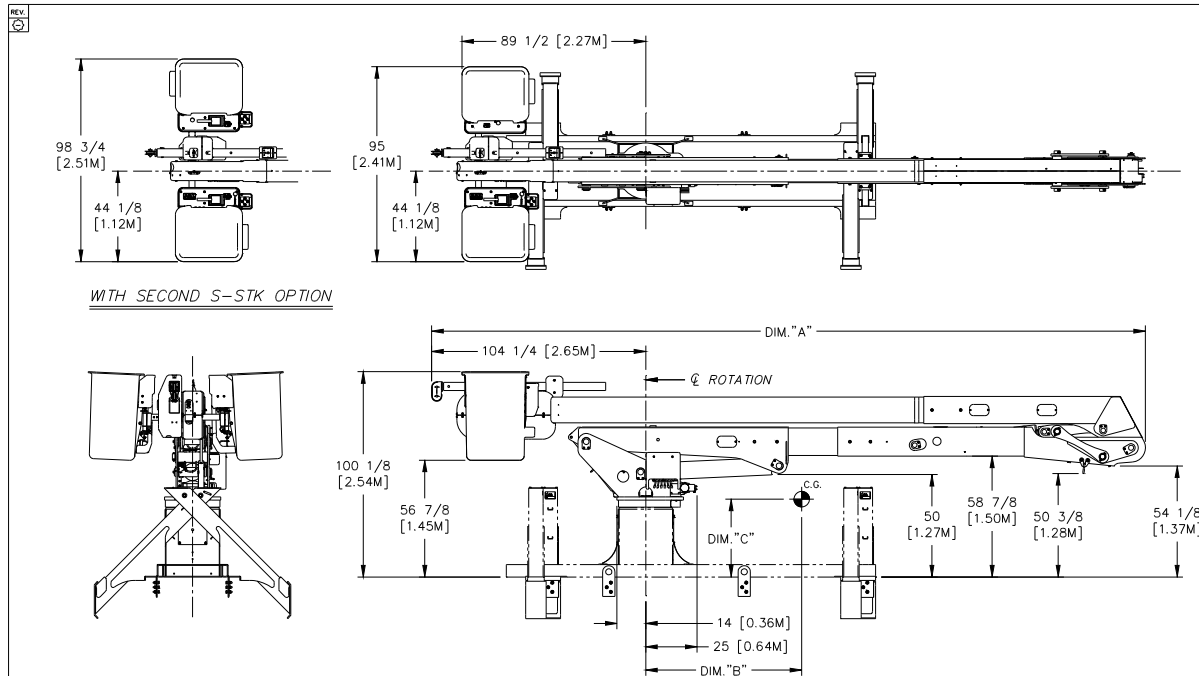

WITH SECOND S-STK OPTION

DUAL PLATFORM MODELS

MODEL	DIM. "A"	APPROX. DIM. "B"	APPROX. DIM. "C"	APPROX. WEIGHT
VO452MHI	330 [8.38M]	48	59	6900 LBS.
VO455MHI	348 [8.84M]	55	59	7000 LBS.

- NOTES:
 1.) 34" STD. PEDESTAL IS SHOWN.
 2.) WEIGHTS DO NOT INCLUDE SUBFRAME, OUTRIGGERS OR MOUNTING HARDWARE.
 3.) DIMENSIONS ARE IN INCHES [METERS].
 4.) THE SUBFRAME WEIGHT IS APPROX. 10 LBS. PER INCH.
 5.) APPROXIMATE OUTRIGGER WEIGHTS:
 A-FRAME.....1150 LBS.
 X-FRAME.....1400 LBS.
 RADIAL.....1600 LBS.

<small>UNLESS OTHERWISE NOTED: TOLERANCES: FRACTIONS ± 1/16 X ± 1.3 ANGLES ± 1' XX ± 0.05 MACHINED SURFACE FINISHES = 125 PROJECTION OF VIEWS = 1 ALL DIMENSIONS ARE IN INCHES THIS PRINT CONTAINS CONFIDENTIAL INFORMATION AND IS SOLE PROPERTY OF TIME MANUFACTURING, AND IS NOT TO BE DISCLOSED, COPIED, OR REPRODUCED WITHOUT EXPRESSED PERMISSION OF TIME MANUFACTURING.</small>		DWN. BY	DATE	TITLE
		LBR	10-12-11	VO452/455/460 MHI OVERALL
MATERIAL		EST WT #	MANUAL	
FINISH		SHEET	2 OF 2	DWG. NO. 1000084-DWG

SPECIFICATIONS



VO-452/455/460 MINIMUM VEHICLE SPECIFICATIONS

Frame Section Modulus	18 in ³ (295 cm ³)
Frame Resisting Bending Moment	900,000 in-lbs (101686 N-m)
Cab to Rear Axle Dimension	108 in (2.74 m)

VO-452/455/460 with 102° Lower Boom Articulation and Dual A-Frame

GVWR	33,000 lbs (14970 kg)
GAWR (FRONT)	12,000 lbs (5440 kg)
GAWR (REAR)	21,000 lbs (9520 kg)

VO-452/455/460 with 110° or 120° Lower Boom Articulation and Dual A-Frame

GVWR	36,000 lbs (16330 kg)
GAWR (FRONT)	13,000 lbs (5900 kg)
GAWR (REAR)	23,000 lbs (10430 kg)

VO-452/455/460 with 102° Lower Boom Articulation and one A-Frame and one X-Frame

GVWR	33,000 lbs (14970 kg)
GAWR (FRONT)	12,000 lbs (5440 kg)
GAWR (REAR)	21,000 lbs (9520 kg)

VO-452/455/460 with 110° or 120° Lower Boom Articulation and one A-Frame and one X-Frame

GVWR	36,000 lbs (16330 kg)
GAWR (FRONT)	13,000 lbs (5900 kg)
GAWR (REAR)	23,000 lbs (10430 kg)

VO-452/455/460 with 102°, 110°, or 120° Lower Boom Articulation and Dual X-Frame

GVWR	33,000 lbs (14970 kg)
GAWR (FRONT)	12,000 lbs (5440 kg)
GAWR (REAR)	21,000 lbs (9520 kg)

VO-452 Approximate Curb Weight for Stability

Outriggers	Lower Boom Articulation					
	102°		110°		120°	
Dual A-Frame	28000 lbs	12700 kg	31500 lbs	14300 kg	32000 lbs	14550 kg
One A-Frame, one X-Frame	26000 lbs	11800 kg	29500 lbs	13400 kg	30000 lbs	13650 kg
Dual X-Frame	24500 lbs	11150 kg	28000 lbs	12700 kg	28000 lbs	12700 kg

VO-455 Approximate Curb Weight for Stability

Outriggers	Lower Boom Articulation					
	102°		110°		120°	
Dual A-Frame	29000 lbs	13200 kg	32000 lbs	14550 kg	31500 lbs	14300 kg
One A-Frame, one X-Frame	27000 lbs	12250 kg	30000 lbs	13650 kg	29500 lbs	13400 kg
Dual X-Frame	25500 lbs	11600 kg	28000 lbs	12700 kg	27500 lbs	12500 kg

VO-460 Approximate Curb Weight for Stability

Outriggers	Lower Boom Articulation					
	102°		110°		120°	
Dual A-Frame	29500 lbs	13400 kg	32500 lbs	14750 kg	30500 lbs	13850 kg
One A-Frame, one X-Frame	27500 lbs	12500 kg	30500 lbs	13850 kg	29000 lbs	13200 kg
Dual X-Frame	26000 lbs	11800 kg	29000 lbs	13200 kg	27000 lbs	12250 kg

Notes:

- Actual GVWR and GAWR should be based on the weight and weight distribution of the chassis, body, lift ballast (if required), and accessories, plus the desired payload. Weights shown above are based on a typical installation on a 4x2 chassis.
- Actual curb weight for stability will vary with rated platform capacity, mounting configuration, frame stiffness, and stability test requirements. The values provided are for reference only. The actual curb weight required to pass the ANSI A92.2 stability test may be higher or lower.

SPECIFICATIONS

REV.	ERCN NO.	DESCRIPTION	BY	CHKD.	APPR.	DATE
59541		FIRST RELEASE	LBR	DJH	SRS	10-12-11

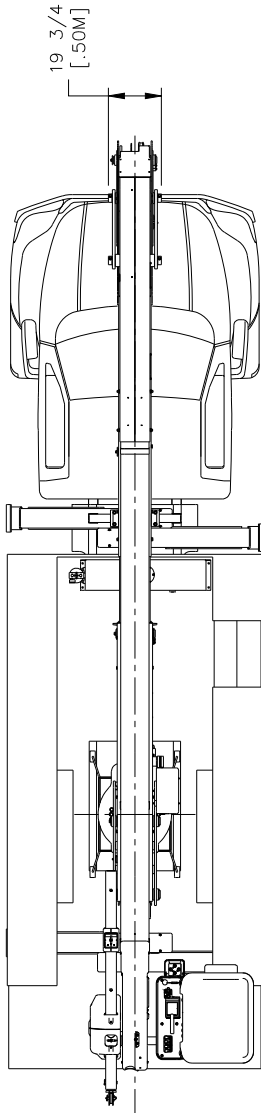

VO455MHI WITH SINGLE PLATFORM SHOWN

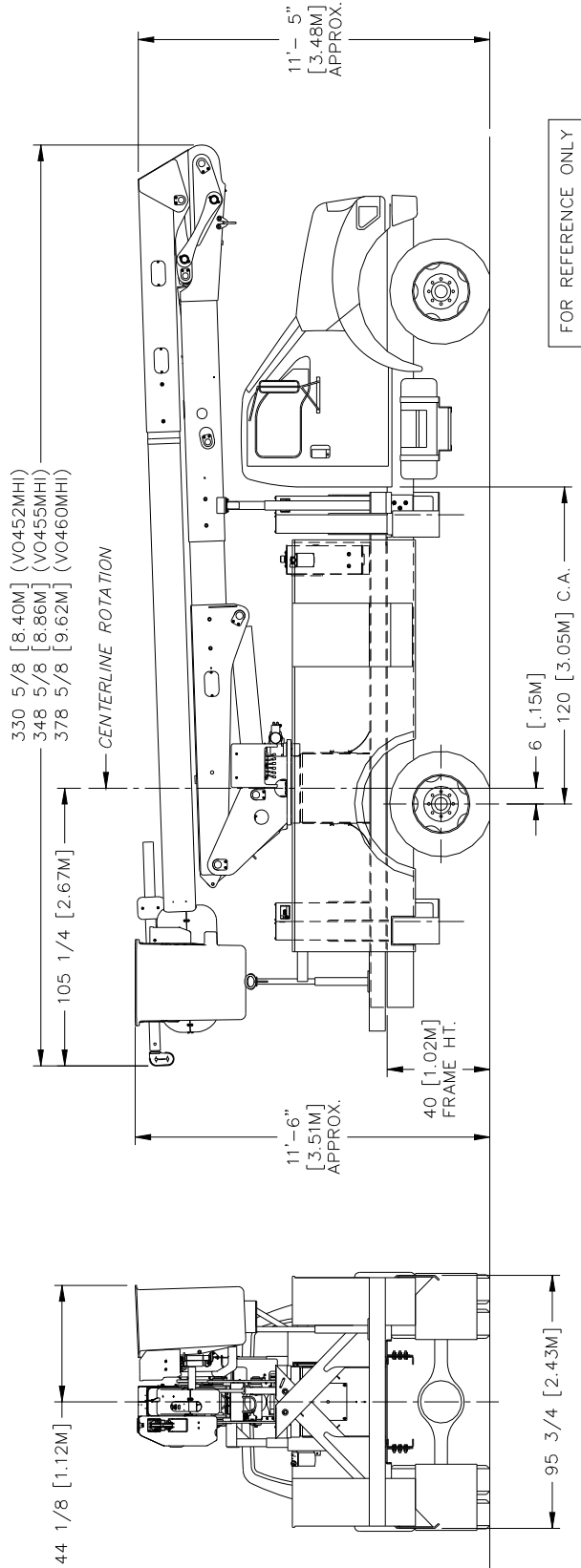

<p>UNLESS OTHERWISE NOTED: TOLERANCES: DECIMALS ± .1 FRACTIONS ± 1/16 ANGLES ± .05 .XX ± .05 .XXX ± .05 MACHINED SURFACE FINISHES: Ra .125 PROJECTION OF VIEWS: A DIMENSIONS ARE IN INCHES THIS DRAWING IS THE SOLE PROPERTY OF TIME MANUFACTURING AND IS NOT TO BE DISCLOSED, COPIED, OR REPRODUCED WITHOUT THE PERMISSION OF TIME MANUFACTURING.</p>	<p>MANUFACTURING COMPANY WACO TEXAS</p>	<p>DWN. BY LBR</p>	<p>DATE 10-12-11</p>	<p>TITLE INSTALLATION OUTLINE</p>
	<p>MATERIAL</p>	<p>SCALE A</p>	<p>EST WT # 1=65</p>	<p>VO452/455/460MHI</p>
	<p>FINISH</p>	<p>SHEET 1 OF 1</p>	<p>DWG. NO. 1000083-DWG</p>	



OPERATION

This chapter provides operators and ground crew with recommended aerial lift operating procedures, descriptions and detailed operating information about the controls at each control station. Operators and ground crews are responsible for knowing and applying this information to job site situations.

Only properly trained operators are qualified to operate the **Versalift** aerial lift. Operator training shall include complete instruction and understanding of the manufacturer's manuals, employer's work rules, and all related governmental regulations. Prior to operation from the platform the machine must be operating properly, must have been installed properly, inspected, and maintained in accordance with the manufacturer's instructions. All safety signs, guards, and covers must be in place and in proper condition.

⚠ DANGER: AN UNTRAINED OR CARELESS OPERATOR SUBJECTS HIM/HERSELF AND OTHERS TO DEATH OR SERIOUS INJURY.

It is the responsibility of the operator and ground crew to make certain that the identification, operation, and instructional decals are not lost, damaged, or illegible. If these conditions exist the decals must be replaced before lift operation. Refer to the Decal Placement illustration in Section 6 of this manual for decal location and parts listing.

PRIOR TO OPERATING THE AERIAL LIFT, REFER TO "DAILY VISUAL INSPECTION", SECTION 6 OF THIS MANUAL. DAILY VISUAL INSPECTION MUST BE PERFORMED BEFORE OPERATING THE LIFT.

POSITIONING THE VERSALIFT FOR OPERATION

This section describes proper positioning of the VO aerial lift so that it will be as stable and useful as possible. The information in this section includes orientation of the truck at the work site, responsibilities before leaving the truck cab, requirements after leaving the truck cab, and engaging the outriggers.

ORIENTING THE TRUCK AT THE WORK SITE:

Be sure to park the truck on firm level ground. Do not operate the unit on a slope greater than 5° (1 foot rise in 12 feet) on units not equipped with outriggers. On units with outriggers, aerial device must be leveled

within 2° of horizontal prior to operation. Refer to the slope indicators provided on the chassis to show whether the aerial device is positioned within limits permitted. Slope reduces the vehicle's stability and places additional stress on the lift and components. Maintaining the correct tire pressure and engaging the outriggers contribute to vehicle stability. If there is any doubt about vehicle stability under any condition, do not operate the lift.

⚠ DANGER: NEVER OPERATE THE LIFT ON A SLOPE GREATER THAN 5°. WITHOUT PROPER STABILITY THE UNIT MAY TIP RESULTING IN DEATH OR SERIOUS INJURY.

RESPONSIBILITIES BEFORE LEAVING THE TRUCK CAB:

Perform the following steps in preparing to operate the aerial lift. It is assumed that the truck engine is still running. If the lift is powered by an auxiliary engine (optional power unit) it is not necessary for the truck engine to remain running.

1. Set the parking brake and the brake lock (if equipped).
2. Shift the truck transmission into neutral. This is necessary because the truck engine must be running for the lift to operate. Omit this step if an auxiliary engine is used to power the lift hydraulics.
3. Turn on the warning light flashers.
4. Depress the clutch (manual transmissions) and engage the PTO, if equipped. Refer to "Power Take-Off" in this section.
5. Activate the master control with the toggle switch on the truck dashboard. A red light next to the toggle switch on the dashboard indicates when the master control system is energized. The truck ignition must be on unless equipped with an auxiliary engine.

REQUIREMENTS AFTER LEAVING THE TRUCK CAB:

1. Check wind and weather conditions. Do not operate the platform if wind gust exceeds 30 mph (48 km/hr) or there is a threat of an electrical storm.
2. After leaving the cab chock the wheels. This is extremely important because the brake systems on some larger trucks have a critical weakness. For example: the brakes may be engaged by

locking the drive shaft behind the transmission. If the weight is reduced from one or both of the rear wheels, by the position of the lift, the truck differential can allow the truck to roll. Refer to Figure 4.1 diagram for proper way of chocking the wheels.

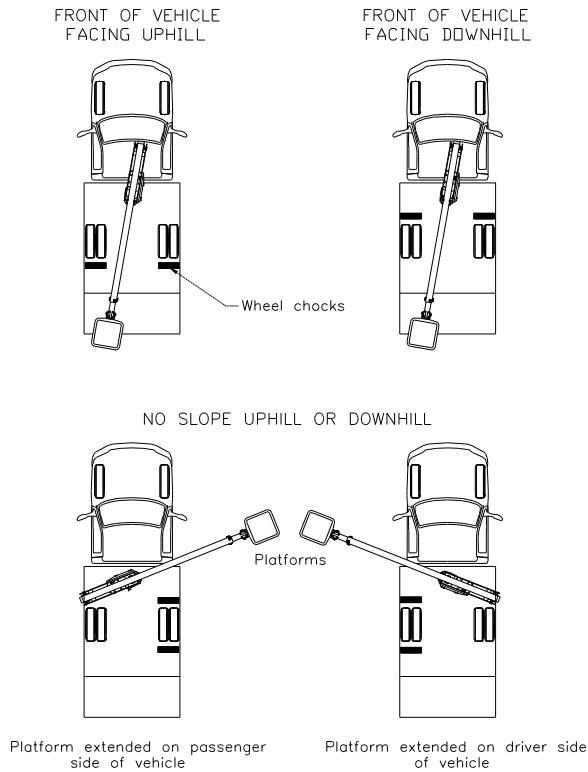

Wheel Chocking Diagram
Figure 4.1

⚠ DANGER: NEVER OPERATE THE LIFT WITHOUT SETTING THE PARKING BRAKE AND CHOCKING THE WHEELS. A ROLLING TRUCK MAY CAUSE AN ACCIDENT RESULTING IN DEATH OR SERIOUS INJURY.

3. Set up adequate cones or barricades to mark the boundaries of the work site and alert pedestrians and motorists. Never work outside the boundaries.

OUTRIGGERS(If equipped) - To operate the outriggers see "Outrigger Controls" in this section.

After the truck has been properly parked on level ground, and the outriggers have a clear path to the ground, lower all the outriggers until there is firm contact with the ground. When the ground is too soft for the outriggers to be effective place outrigger pads

on the ground to increase the bearing area.

If the truck is parked on sloping ground so that one side of the truck is lower than the other side, extend the low-side outrigger first so that firm contact is made with the ground. This will avoid tilting the truck even more to the low-side when the high-side outrigger is lowered.

If one or both outriggers (of a pair) are not fully extended, the outrigger spread is reduced. This reduces the stability of the aerial lift. For example, when an outrigger rests on a curb the outrigger spread is reduced.

The stability of the truck depends on the unit's gross weight, firmness and slope of the ground, weight in the platform or load on the lifting eye, tire pressure, and outrigger spread. These factors are widely variable and caution must be used when determining the stability of the unit. If, under any condition, there is doubt about vehicle stability, do not operate the lift.

⚠ DANGER: NEVER OPERATE WITHOUT EXTENDING THE OUTRIGGERS (IF EQUIPPED). WITHOUT PROPER OUTRIGGER EXTENSION THE UNIT MAY TIP RESULTING IN DEATH OR SERIOUS INJURY.

AERIAL LIFT OPERATIONS

This section emphasizes overall operating practices for aerial lift operation. This information appears in an order of probable use while operating from the ground, then at the platform and close to energized conductors.

Start Up Procedures When Operating From the Ground: It is assumed the truck has been positioned for operation as described in this section.

In extremely cold weather allow the aerial lift to idle a few minutes before engaging a load. Further consideration of cold weather operation is addressed in Service Procedures Section of Service Manual, "Hydraulic Oil Recommendations".

After the outriggers have been lowered to increase stability, disengage the upper boom tie-down strap. Select "turret" with the control selector lever at the lower controls. Refer to diagram of the lower controls in this section. Note: If an aerial device has been idle for an extended length of time it must be operated from the lower controls through its full range of motion several times before an operator enters the platform. This procedure will allow the operator to confirm the

lift is operating properly and to purge any air the hydraulic system.

If there is any malfunction during this empty test run, shut down the unit immediately. Do not operate the lift again until the problem has been corrected by the service department.

Operate each lift function from the lower controls by constantly holding the 3-position selector valve control handle in the lower controls position while slowly moving the appropriate spring-loaded control handle in the desired direction, as indicated by the decal, until motion begins. All boom movements must be started and stopped gradually.

⚠ DANGER: NEVER START, REVERSE, OR STOP THE DIRECTION OF LIFT TRAVEL SUDDENLY AND AVOID REACHING THE END OF BOOM RANGE AT EXCESSIVE SPEEDS. STRUCTURAL DAMAGE OR INSTABILITY MAY RESULT CAUSING DEATH OR SERIOUS INJURY.

The range each boom will raise and lower is mechanically limited. An operator must always be aware of these mechanical limits and avoid reaching the end of the boom's range at an excessive speed. To do so stresses the lift and chassis unnecessarily and may cause instability. Notice that rotation is not limited. The lift can rotate continuously.

Operating Procedures From The Platform:

Complete the start-up procedure from the ground before selecting the upper controls with the 3-position control selector. In order to operate the lift from the platform, select the upper controls with the 3-position selector lever at the lower control station. Verify that the upper boom tie-down strap is disengaged. Using the step(s) provided, carefully enter the platform. Safety regulations require the operator to be secured with a personnel restraint system to the lift. The safety belt must be secured around the waist. The lanyard is a connecting strap. The "Energy Absorber" end of the lanyard always connects to the body belt or harness and the other end connects to a lanyard anchor at the platform support weldment. The safety belt must be rotated so that the lanyard connection is centered on his back.

⚠ DANGER: NEVER OPERATE ANY AERIAL EQUIPMENT WITHOUT WEARING AN APPROVED PERSONNEL RESTRAINT SYSTEM ATTACHED TO THE ANCHOR. FAILURE TO PROPERLY SECURE THE SAFETY BELT AND

LANYARD MAY RESULT IN DEATH OR SERIOUS INJURY IN THE EVENT OF A FALL FROM THE PLATFORM.

Before operating the lift the operator should study, "Upper Control Operation" in this section.

Operating Where Electrical Hazards Are Present: It is imperative that the aerial device operator understand the dangers associated with operating near electrical hazards. Due to the work involved, the ordinary uses of aerial lift often place the operator and ground crew in the vicinity of electrical lines and equipment where grave danger exists. These dangers can only be avoided by the constant care of an operator who is aware of these dangers, knows the limitations of the aerial lift and its insulating sections, and knows how to protect himself and the crew from these dangers.

⚠ DANGER: ALL COMPONENTS IN THE PLATFORM AREA, INCLUDING THE CONTROLS, JIB POLE, COVERS, ETC. SHALL BE CONSIDERED ELECTRICALLY CONNECTED, AND NOT INSULATED OR ISOLATED. THESE COMPONENTS MAY CONDUCT ELECTRICITY RESULTING IN DEATH OR SERIOUS INJURY.

The insulation capabilities of this aerial lift are defined by the rated line voltage on the ANSI A92.2 data plate. Although the aerial unit provides insulated booms, no aerial lift can provide protection from contact with or proximity of an electrically charged power line when you are in contact with or in proximity of another power line. Maintain safe clearances from electrical power lines in accordance with applicable government regulations. Make certain to allow clearance for boom, platform, electrical line, and load line sway and deflection.

⚠ DANGER: CONTACT WITH OR INADEQUATE CLEARANCE FROM ELECTRICAL POWER LINES AND APPARATUS WILL CAUSE DEATH OR SERIOUS INJURY.

The accumulation of dirt and moisture on insulated booms degrades the insulation. Be sure the booms are clean and dry. Remember that the inside of a boom may be wet even when the outside is dry. Any equipment which bridges the platform and the ground voids the insulation and must be eliminated when working near areas of electrical hazard.

⚠ DANGER: *EQUIPMENT WHICH BRIDGES THE PLATFORM AND GROUND RENDERS THE INSULATION USELESS AND MAY RESULT IN DEATH OR SERIOUS INJURY IN THE EVENT OF AN ELECTRIC SHOCK.*

⚠ DANGER: *GIVE WARNING AND NEVER ALLOW ANYONE ON THE GROUND TO TOUCH THE UNIT WHEN THE LIFT IS BEING USED TO WORK ON OR NEAR ELECTRICAL LINES. IF THE UNIT BECOMES ENERGIZED DEATH OR SERIOUS INJURY MAY RESULT FROM CONTACT WITH THE UNIT.*

⚠ DANGER: *CONTACT BETWEEN AN ELECTRICALLY CHARGED WIRE AND A METAL PART OF THE BOOM MAY CAUSE THE WIRE TO BURN THROUGH, LETTING THE TWO LOOSE WIRE ENDS FALL TOWARD THE GROUND. THIS MAY CAUSE DEATH OR SERIOUS INJURY TO INDIVIDUALS ON THE GROUND.*

As previously stated, it is the responsibility of the operator and the ground crew to know and understand the capabilities of the aerial lift and hazards associated with operation near electric lines or components. In addition they must apply this knowledge to situations that arise on the job for safe and efficient operation.

CAB CONTROL OPERATION

The cab controls include the master control, the engine start/stop control, and the PTO (Power Take-Off) shifter.

MASTER CONTROL (Standard) - The master control consists of a toggle switch and a light mounted on the dashboard of the truck. The toggle switch is used to energize or de-energize the start/stop system and the throttle control options. When the light is lit the toggle switch is energizing these systems.

ENGINE START/STOP (Standard) - The engine start/stop is a push button control and is usually mounted on the dashboard of the truck. The system is activated by pushing and holding the button momentarily to “start” the engine. If the engine does not crank then the start/stop button may require a second push to get the latching relay into the “start” position so the truck engine will turn over. Then to deactivate the engine press the start/stop button again. This feature is especially convenient when the lift is being operated from the lower (turret) controls.

⚠ DANGER: *THE TRUCK TRANSMISSION MUST BE IN NEUTRAL BEFORE USING THE ENGINE START/STOP. STARTING THE ENGINE WITH THE TRUCK IN GEAR WILL CAUSE MOVEMENT WHICH MAY CAUSE DEATH OR SERIOUS INJURY TO THE OPERATOR OR ANYONE IN THE PATH OF THE TRUCK.*

(PTO) POWER TAKE-OFF (If So Equipped.) - The power take-off is a gearbox used to transmit power from the truck transmission to the hydraulic pump, which provides hydraulic oil for the aerial lift functions. The power take-off control consists of a toggle switch and a red light mounted in the truck dashboard. When the red (PTO) indicator is lighted the PTO is activated. The operator must never drive the truck with the PTO engaged.

⚠ CAUTION: *DRIVING WITH THE PTO ENGAGED MAY DAMAGE THE TRANSMISSION, PUMP, AND/OR THE PTO.*

To engage the power take-off properly refer to the operating instructions located in the PTO manufacturer’s owner manual. If the PTO control is not responding properly or if the manufacturer’s operating decals are not posted in the cab (near the control) notify the appropriate personnel for correction.

GROUND CONTROL OPERATION

The ground controls may include one or more of the following controls: outrigger, outrigger/boom interlock, and tool power. Ground controls are usually mounted on panels in the rear bumper of the truck or below the deck of the unit. Descriptions and operating procedures for these controls are given in the following text.

OUTRIGGER OPERATION - The outriggers should always be extended to provide stability for the aerial lift. The outrigger controls consist of a control selector and a control valve as shown in Figure 4.2.

OUTRIGGER/BOOM INTERLOCK - The outrigger/boom interlock is a feature designed to prevent the lift from being operated until the outriggers are properly extended. The interlock also prevents the outriggers from being retracted before the lift is properly stored. This option is particularly useful in keeping unauthorized personnel from operating the outriggers

while an operator is working aloft.

Note: The operation of an outrigger interlocking device (s) does not assure aerial device stability. It serves only to remind the operator that the outriggers have not been deployed.

The controls for operating the outrigger/boom interlock include a detented control selector and a control valve. These controls are usually mounted in the ground control panel similar to the arrangement shown in Figure 4.2. ANSI A92.2 standards require that the outrigger control valve be located where the operator can watch each outrigger raise and lower as the control valve lever is activated.

Lowering the Outriggers With an Outrigger/Boom Interlock System: To lower the outriggers select “ground controls” with the control selector. Then operate the outriggers as described previously. Select “lift controls” with the control selector in order to begin operating the booms.

Retracting the Outriggers With an Outrigger/Boom Interlock System: The booms must be stowed before the interlock system will allow the outriggers to be retracted. Stow the booms as described in this section, “Storing the Aerial Lift”. Select “ground controls” with the detented control selector. Then raise the outriggers as described previously.

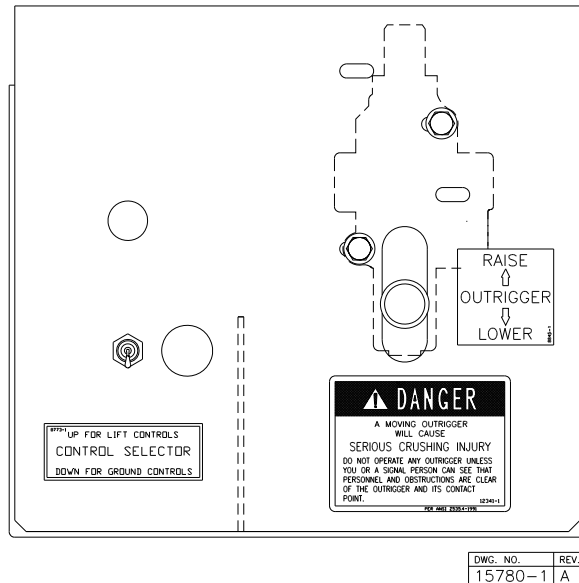

Ground Control Panel With an Outrigger/Boom Interlock System
Figure 4.2

HYDRAULIC TOOL OPERATION AT THE GROUND (Optional) - The aerial lift can be equipped with open-center or closed-center hydraulic tools that operate

at 3000 PSI (211 kg/cm²) and 10 GPM (38 LPM) at the ground controls. A pressure and flow limit valve is optional. Select outrigger operation at the ground controls. Then connect the hydraulic tool hoses to the tool power outlets (quick-disconnect couplings) and activate the tool power valve by pulling the tool power valve knob “out”. The other aerial lift controls will not respond while the hydraulic tools are being operated. To disconnect the hydraulic tools, the tool power valve must be turned “off” so that the pressure in the system is relieved. This is done by pushing the tool power valve knob “in”. Then the tool hoses can be disconnected safely and easily from the tool power outlets (quick-disconnect couplings). The tool power controls are shown in Figure 4.3.

WARNING: FAILURE TO RELIEVE PRESSURE TO THE TOOL PORTS BEFORE CONNECTING OR DISCONNECTING THE HYDRAULIC TOOL HOSES MAY RESULT IN A HIGH PRESSURE HYDRAULIC OIL SPRAY. THIS SPRAY OR MIST CAN PUNCTURE OR BECOME EMBEDDED BENEATH THE SKIN OR CONTAMINATE THE EYES. THESE CONDITIONS REQUIRE IMMEDIATE MEDICAL ATTENTION.

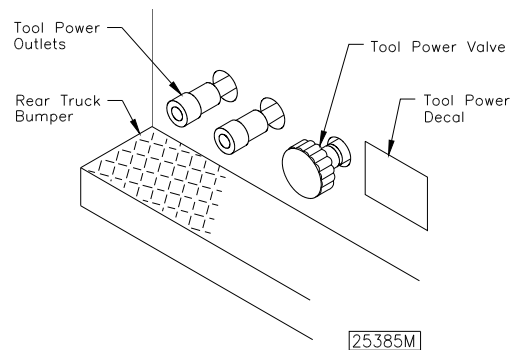

Tool Power Controls
Figure 4.3

LOWER CONTROL OPERATION

DANGER: DEATH OR SERIOUS INJURY MAY RESULT IF CHASSIS BECOMES ENERGIZED. DO NOT OPERATE THE AERIAL DEVICE WHILE CREATING A PATH TO THE GROUND.

The Lower Controls are located on the turret as shown Figure 4.4.

CONTROL SELECTOR LEVER - The detented control



selector is used to select operation of the aerial lift from the upper or lower controls. Also this control serves as the emergency stop for the upper controls.

BOOM CONTROL LEVERS - The remaining control levers at the lower control station are spring-loaded. The lower control decal identifies the function of each control lever and indicates which direction to move the control lever for the desired movement. When released the control lever will return to the centered or neutral position and motion ceases.

PLATFORM LEVELING CONTROL - This control activates the hydraulic platform leveling to level the platform.

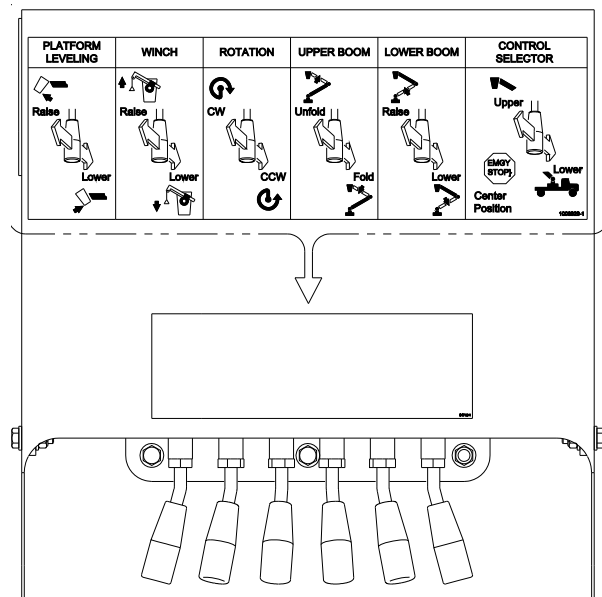

Lower Controls At The Turret
Figure 4.4

ELECTRIC SELECTOR STATION - The electric controls at the pedestal are arranged as shown in Figure 4.5. A description of each control and the method of operation is given below.

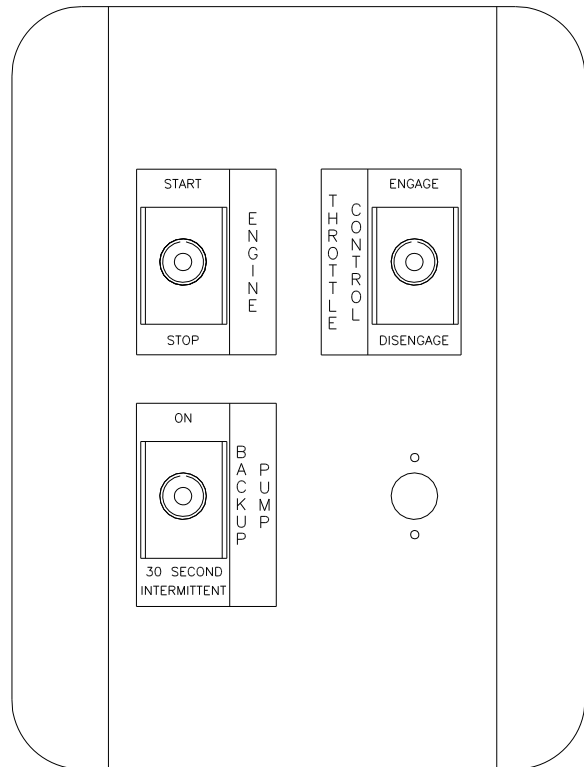

Electric Control Station at the Pedestal
Figure 4.5

ENGINE START/STOP CONTROL (Standard) - The engine start/stop control is convenient for the ground crew at the pedestal. The engine start/stop control is operated by a three-position toggle switch.

To start the engine from the pedestal, push the toggle to the “START/STOP” position and hold the toggle in that position for a moment until the engine starts. Allow the toggle to return to the neutral or centered position.

To stop the engine from the pedestal, push the toggle to “START/STOP” again. Allow the toggle to return to the neutral or centered position. Refer to Section 5, “Emergency Operation” for information on the use of this control in an emergency.

TWO-SPEED MANUAL THROTTLE CONTROL (Option) - Gives the operator a choice of efficient, economical engine idle speed or higher engine speed when faster lift movements are required. The two-speed throttle control will operate only if the master control is activated. The two-speed throttle control is operated by a three-position toggle switch at the pedestal.

To speed up the engine from the pedestal, push the toggle to the “ENGAGE” position. Allow the toggle to return to the neutral or centered position.

To slow the engine to an idle from the pedestal, push the toggle to the “DISENGAGE” position. Allow the toggle to return to the centered or neutral position.

BACKUP PUMP CONTROL (Option) - If the aerial lift main power source fails, the backup pump option can be activated to operate the lift. The backup pump control is a detented toggle switch located at the pedestal. The backup pump system should not be operated longer than 30 seconds continuously. Continuous use will drain the battery and damage (over heat) the backup pump motor.

To activate the backup pump from the pedestal, push the toggle switch to the “ON” position and operate the appropriate lift controls.

To deactivate the backup pump from the pedestal, push the toggle switch down (towards the “30 SECOND INTERMITTENT” message).

UPPER CONTROL OPERATION

This section describes how the operator can identify and operate the upper controls (at the dual platforms). Never allow an untrained individual to operate the aerial lift.

⚠ DANGER: AN UNTRAINED OR CARELESS OPERATOR SUBJECTS HIM/HERSELF AND OTHERS TO DEATH OR SERIOUS INJURY.

When operating the lift all lift movements must be started and stopped gradually.

⚠ DANGER: NEVER REVERSE OR STOP THE DIRECTION OF THE LIFT TRAVEL SUDDENLY AND AVOID REACHING THE END OF THE BOOM TRAVEL AT EXCESSIVE SPEEDS. STRUCTURAL DAMAGE OR INSTABILITY MAY RESULT CAUSING DEATH OR SERIOUS INJURY.

Never operate the upper controls without using the personnel restraint system.

Speed and smoothness of lift operation are controlled by feathering the control valves. Feathering a control function allows the operator to change the speed by adjusting how far the control is moved. Flow can be directed to one function or multiple functions

simultaneously. Function speed depends on flow to each valve. Regular practice will develop operator proficiency.

SINGLE STICK CONTROL - Refer to Figure 4.6 for clarification. This multi-jointed handle operates the valve spools and enables the operator to control all lift movements. The three bi-directional handle movements (in-out, up-down, and right-left) are illustrated on the placard mounted on top of the single stick control.

Lift operations are selected by depressing the safety trigger while actuating the single stick control handle. Slowly move the single stick handle in the desired direction until motion begins. Further movement of the handle in the same direction will increase the speed of the motion. To stop a lift movement, move the single stick lever back to the neutral position and release the trigger. Releasing the safety trigger in any position except neutral will cause the selector valve to slam shut and stop lift travel with an abrupt jerking motion resulting in unnecessary loads and stresses.

To operate two or more functions at the same time, position the single stick handle anywhere in an area between the separate paths of the desired functions.

HYDRAULIC TOOL POWER (Standard) - The hydraulic tool ports are located on the side of the upper controls. Always relieve the pressure to the tool ports before connecting or disconnecting the hydraulic tool hoses. To relieve the pressure, move the tool selector handle to the “OFF” position. Then connect or disconnect the hydraulic tool hoses to the tool ports. (Quick Disconnect Outlets). Activate operating pressure to the hydraulic tools by moving the tool selector to the “ON” position.

⚠ WARNING: FAILURE TO RELIEVE PRESSURE TO THE TOOL PORTS BEFORE CONNECTING OR DISCONNECTING THE HYDRAULIC TOOL HOSES MAY RESULT IN A HIGH PRESSURE HYDRAULIC OIL SPRAY. THIS SPRAY OR MIST CAN PUNCTURE OR BECOME EMBEDDED BENEATH THE SKIN OR CONTAMINATE THE EYES. THESE CONDITIONS REQUIRE IMMEDIATE MEDICAL ATTENTION.

EMERGENCY STOP (Standard) - The primary purpose of the emergency stop valve is to deactivate all the upper controls in the event of a control valve malfunction (i.e. a valve spool stuck in the open position) or other hydraulic emergency. Push the

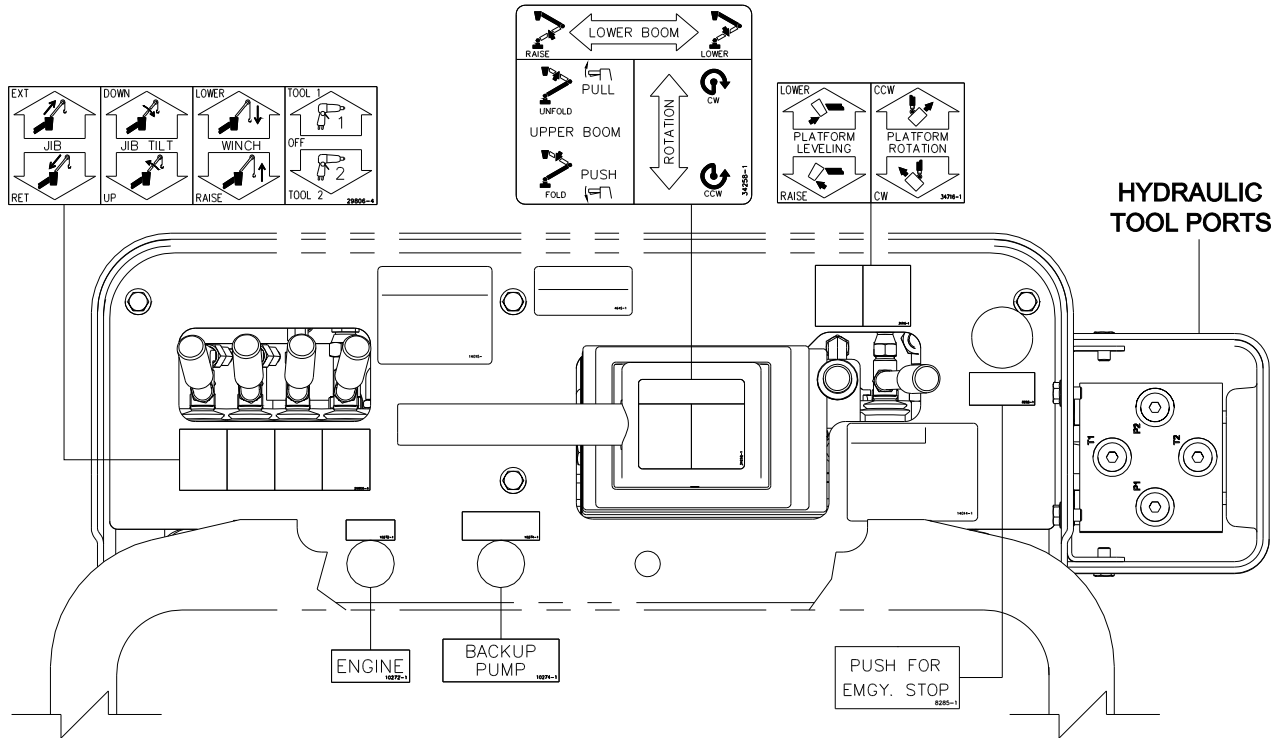

Single Stick Upper Controls
Figure 4.6

knob labeled “PUSH FOR EMGY. STOP”; then the upper controls are inoperable and pressure at the tool ports is relieved. When the emergency stop knob is pulled up, the upper controls and tool power are functional.

ENGINE START/STOP CONTROL (Standard) - The engine start/stop control has been designed so that the lift cannot be operated unless the truck ignition is in the “RUN” position and the master control is “ON”. This feature makes it difficult for unauthorized individuals to operate the lift when the truck is locked. The engine start/stop system is operated by an air cylinder at the upper controls.

⚠ DANGER: THE TRUCK TRANSMISSION MUST BE IN NEUTRAL BEFORE USING THE ENGINE START/STOP. STARTING THE ENGINE WITH THE TRUCK IN GEAR WILL CAUSE MOVEMENT WHICH MAY CAUSE DEATH OR SERIOUS INJURY TO THE OPERATOR IN THE LIFT OR ANYONE IN THE PATH OF THE TRUCK.

To start the truck engine from the platform, push the air cylinder plunger knob down and hold the knob until the engine starts. If the truck starter does not engage, release the plunger knob and allow the plunger to rise to the neutral position. A second push on the plunger may be required to get the latching

relay into position so the engine will start.

To stop the truck engine from the platform, push the air cylinder plunger knob down to get the latching relay into the “stop” position.

BACKUP PUMP CONTROL (Option) - The backup pump system is operated by an air cylinder plunger knob. **The backup pump system should not be operated longer than 30 seconds continuously.** Continuous use will drain the battery and damage (over heat) the backup pump motor.

To activate this system from the upper controls, push the air cylinder knob down and hold it while operating the lift controls.

To turn off the backup pump from the upper controls, release the knob and allow it to return to the neutral position.

PLATFORM ROTATION - This control rotates the platform clock-wise and counter-clockwise through a total travel of 90°.

HYDRAULIC PLATFORM TILT - This control can be used to level the platform and to dump the platform for clean out or rescue.

JIB TILT - This control tilts the jib pole a total of 125° relative to the upper-boom.

WINCH - This control raises and lowers the winch line.

JIB EXTENSION (Optional) - This control extends and retracts the jib-pole.

STORING THE AERIAL LIFT

Storing the booms for road travel requires a combination of boom/platform lowering and rotating movements. Prior to lowering the boom into the rest, it must be centered over the rest. The aerial lift design will allow either the upper boom or the lower boom to be stored first with no adverse effects.

⚠ DANGER: ALWAYS WATCH FOR PERSONNEL AND OBSTRUCTIONS WHEN STORING THE AERIAL LIFT. A CRUSHING INJURY TO PERSONNEL OR DAMAGE TO THE UNIT CAN OCCUR.

STORING THE LOWER BOOM - As the lower boom approaches the boom rest, the operator should use the lift controls to reduce the speed of the lower boom's descent.

STORING THE UPPER BOOM - Store the upper boom into the boom cradle carefully.

STORING THE JIB AND WINCH - To prevent jib pole damage and for minimum travel height and rear overhang, tilt the jib-pole to horizontal. Then fully retract the jib-pole before stowing the upper boom.

⚠ CAUTION: FAILURE TO PROPERLY STOW THE JIB-POLE ASSEMBLY INCREASES THE TRAVEL HEIGHT OF THE UNIT AND WILL CAUSE DAMAGE IF PASSING UNDER A LOW OBSTACLE.

TO COMPLETE THE STORING PROCEDURE - Secure the upper boom with the tie-down strap, retract the outriggers, and remove the wheel chocks. Turn the electrical control system off and disengage the PTO pump drive.

⚠ CAUTION: TO PREVENT DAMAGE TO THE UNIT DO NOT DRIVE THE TRUCK UNTIL THE AERIAL LIFT IS STORED AND THE UPPER BOOM IS SECURED WITH THE UPPER BOOM TIE-DOWN STRAP.

⚠ CAUTION: DRIVING WITH THE PTO ENGAGED MAY DAMAGE THE TRANSMISSION, PUMP, AND/OR THE PTO.

AUTO BOOM LATCH (optional) – The automatic boom latch is designed to open automatically when the lift is operated. Stay clear of the latch as it may move at any time depending on the hydraulic system pressure.

Manual over-ride – In case of hydraulic system failure, the auto boom latch may be operated manually.

Over-ride Procedure:

1. **Danger** – Make sure the hydraulic power source is off.
2. Release the spring plunger by rotating the “T” handle.
3. Manually rotate the latch arm 90° clockwise until it snaps and is held by the spring plunger.

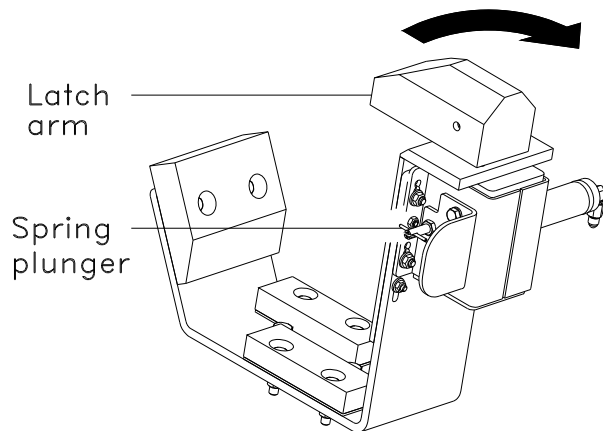

To Release Over-ride:

1. **Caution** – The latch is spring loaded. Keep fingers clear to prevent pinching.
2. Slightly rotate the latch arm clockwise to remove the load from the spring plunger.
3. While holding the latch arm, pull the spring plunger out and rotate the “T” handle to lock the spring plunger in the “out” position.
4. Carefully allow the latch arm to rotate counter-clockwise under spring power until it stops.

LIFTING EYE (OPTION)

⚠ DANGER: NEVER EXCEED THE RATED LOAD CAPACITY OF THE AERIAL LIFT. STRUCTURAL DAMAGE OR INSTABILITY MAY RESULT, CAUSING DEATH OR SERIOUS INJURY.

The optional lifting eye has been designed to accommodate limited material handling. Always extend the outriggers (if so equipped) and fold the upper boom to as near the stowed position as possible when using the boom lifting eye. Boom movements should be smooth to avoid swinging the load. Do not exceed the load limits stated on the decal beside the lifting eye. Do not drag the load with the lifting eye. This is a bad practice and subjects the unit to damaging sideloads. When lifting loads, position the lower boom directly over the load before lifting. The platform should be empty when lifting loads. When the truck is not level, extreme caution must be used when rotating loads toward the low side because the truck stability will be affected. **The platform must not be used for material handling.** The platform was designed to lift personnel only.

⚠ DANGER: INCREASING THE HORIZONTAL DISTANCE FROM THE TRUCK TO THE LOAD WILL REDUCE THE STABILITY OF THE TRUCK AND MAY RESULT IN DEATH OR SERIOUS INJURY.

MATERIAL HANDLING SYSTEM

The material handling system is designed to lift loads from the ground to the work site at the platform. The main components of this system are the jib pole, hydraulic winch, and rope.

Determine the weight of the material to be lifted. Do not lift an unknown load. Refer to the instructions below and the capacity decals to determine the available material handling capacities. Do not exceed the rated lifting capacity. The material handling system is designed for vertical loads only. Do not side load.

⚠ DANGER: DEATH OR SERIOUS INJURY MAY RESULT FROM MISUSE OR FAILURE CAUSED BY MISUSE OF THE AERIAL LIFT OR ITS COMPONENTS. BEFORE OPERATION KNOW

THE INSTRUCTIONS AND LIMITATIONS OF THE LIFT AND THE MATERIAL HANDLING SYSTEM.

⚠ DANGER: DO NOT DEPEND ON THE JIB POLE FOR INSULATION UNLESS THE POLE HAS BEEN RATED, TESTED, AND MAINTAINED FOR THE APPROPRIATE LINE VOLTAGE. THE WINCH ROPE IS NOT CONSIDERED INSULATING. IMPROPER USE OF THE JIB POLE OR WINCH ROPE MAY RESULT IN DEATH OR SERIOUS INJURY.

JIB CAPACITY DETERMINATION

The jib capacity is dependent on the upper boom angle and load line radius. To determine the jib capacity, follow the procedure below.

To Determine Jib Capacity:

Step 1 – Determine the load line radius. The load line radius is the horizontal distance from the centerline of the platform shaft to the winch rope.

Step 2 – Read the jib capacity from the chart. See Figure 4.7

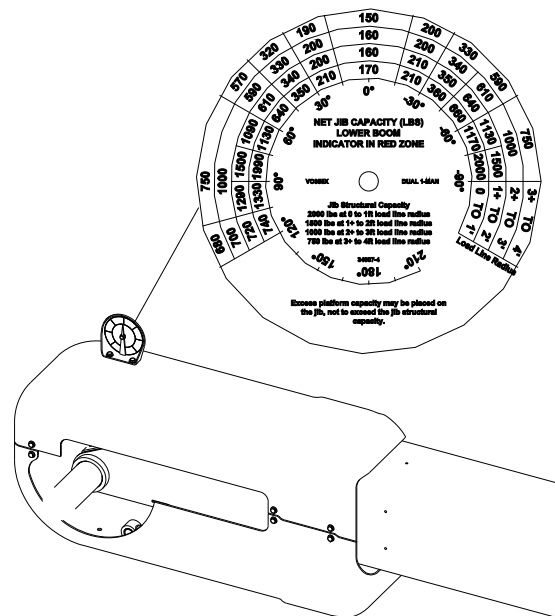

Chart on Upper Boom
Figure 4.7

MANUAL JIB EXTENSION - With the jib pole unloaded and horizontal, the jib pole can be manually extended by removing the retainer pin, sliding the pole to the desired position, and then re-inserting the retainer pin.

HYDRAULIC JIB EXTENSION (Optional) - A hydraulic cylinder extends and retracts the jib pole with or without a load. The cylinder may be pinned to the jib in 2 different positions (3 positions with the optional 6.5 ft jib). Each of these positions provide 18" of travel.

The cylinder may be pinned in another position while under load. To re-pin the cylinder, follow the procedure below:

1. To lengthen the jib, extend the jib pole to near the end of the cylinder stroke. To shorten the jib, retract the jib pole to near the end of the cylinder stroke.
2. Extend or retract the jib pole slightly, to align the transfer hole on the top of the jib with the hole in the jib/winch support structure.
3. Insert the transfer pin through the jib/winch structure and pole. The transfer pin is stored in the upper control panel dash.
4. Extend or retract the jib slightly, to remove the load from the cylinder.
5. Remove the pin connecting the extension cylinder bracket to the jib pole.
6. Extend or retract (as required) to almost the end of the cylinder stroke to align the cylinder with the next hole in the jib pole. Insert the pin through the extension cylinder bracket and jib pole.
7. Slightly extend or retract the jib pole to remove the load from the transfer pin. Remove the transfer pin and stow it back in the control panel.

STOWING THE JIB - The jib must be fully retracted and parallel to the upper boom before stowing the upper boom. This will prevent the jib from contacting the turret, outriggers, etc. when the upper boom is stored.

WINCH - The winch assembly consists of a hydraulic motor, worm gear speed reducer, drum, and rope. The rope includes a clevis hook for attaching a load. A suitable lifting sling or device must be used to attach the load to the hook. Do not wrap the rope around the load; this can severely reduce the strength of the rope.

The winch rope must be treated as a conductor. Dirt, grease, and moisture absorbed by the rope will make

the rope conductive. Therefore, the rope must never be considered an insulator.

LINE LIFTING ATTACHMENT – An attachment is available to lift conductors with the jib pole. This attachment is designed for vertical loads only, and the jib pole must be within 30° of vertical. Refer to the Line lifting instruction decal for capacities.

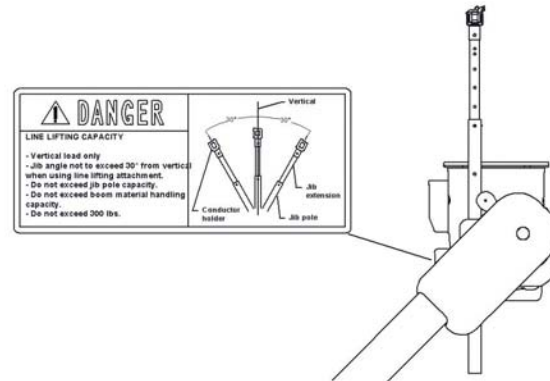

Line Lifting Attachment
Figure 4.8

⚠ DANGER: NEVER EXCEED THE MAXIMUM LIFTING CAPACITY AS SHOWN BY THE CAPACITY INDICATOR. OVERLOADING THE LIFT MAY CAUSE EQUIPMENT FAILURE RESULTING IN DEATH OR SERIOUS INJURY.

⚠ DANGER: IF THE WINCH ROPE HAS ABRASIVE WEAR, PULLED STRANDS, CUTS, HEAT DAMAGE, OR OTHER DEFECTS IT MUST BE REPLACED BEFORE FURTHER USE. THE RECOIL FROM ROPE FAILURE OR FALLING OBJECTS CAN CAUSE DEATH OR SERIOUS INJURY TO THE OPERATOR OR GROUND CREW.

⚠ DANGER: PHASE TO PHASE OR PHASE-TO-GROUND CONTACT OF THE WINCH LINE WILL REDUCE THE STRENGTH OF THE ROPE. THE RECOIL FROM ROPE FAILURE OR FALLING OBJECTS CAN CAUSE DEATH OR SERIOUS INJURY TO THE OPERATOR OR GROUND CREW.

⚠ DANGER: NEVER RAISE A LOAD UNLESS IT IS SECURELY FASTENED. DO NOT USE THE WINCH LINE TO WRAP OR TIE AN OBJECT FOR LIFTING BECAUSE THE HOOK ON THE WINCH LINE MAY DAMAGE OR CUT THE ROPE. THE RECOIL FROM ROPE FAILURE OR

FALLING OBJECTS CAN CAUSE DEATH OR SERIOUS INJURY TO THE OPERATOR OR GROUND CREW.

⚠ DANGER: NEVER USE THE WINCH TO RAISE PERSONNEL OFF THE GROUND. A FALL MAY RESULT IN DEATH OR SERIOUS INJURY.

⚠ DANGER: DO NOT UNDER ANY CIRCUMSTANCE STAND BELOW A SUSPENDED LOAD. DEATH OR SERIOUS INJURY MAY OCCUR IF PERSONNEL ARE STRUCK BY FALLING OBJECTS.

⚠ DANGER: CONTACT BETWEEN AN ENERGIZED CONDUCTOR AND A WINCH ROPE EXTENDED TO THE GROUND OR ANOTHER CONDUCTOR MAY COMPLETE A PATH FOR ELECTRICITY AND CAUSE DEATH OR SERIOUS INJURY TO THE OPERATOR OR GROUND CREW.

⚠ DANGER: MAKE CERTAIN THE WINCH ROPE COILS ARE SPOOLING EVENLY TO AVOID CLOGGING THE WINCH OR PRODUCING SHOCK LOADS. AVOID SHOCK LOADS CAUSED BY JERKING A LINE WITH A LOAD OR SUDDEN CHANGE IN TENSION FROM A LIGHT TO A HEAVY LOAD. SHOCK LOADS MAY CAUSE STRUCTURAL DAMAGE OR INSTABILITY RESULTING IN DEATH OR SERIOUS INJURY.

⚠ DANGER: THERE MUST BE AT LEAST 5 COILS OF ROPE WOUND ON THE WINCH REEL AT ALL TIMES BECAUSE THE WINCH DRUM AND ROPE ATTACHMENT ARE NOT DESIGNED FOR FULL ROPE EXTENSION. THE RECOIL FROM ROPE DETACHMENT OR FALLING OBJECTS CAN CAUSE DEATH OR SERIOUS INJURY TO THE OPERATOR OR GROUND CREW.

OPERATION

EMERGENCY OPERATION

Emergency operation may be required if an operator is injured or the hydraulic system malfunctions. The purpose of this chapter is to help qualified operators become proficient with the controls and features designed to accommodate emergency operation and to describe the procedures for responding to emergency situations. In any emergency the first priority is always the safety of the personnel involved. Before attempts are made to rescue personnel always make sure the unit has not become electrically energized. It is important to follow standard work practices and safety regulations.

⚠ DANGER: *BEFORE ATTEMPTING TO RESCUE PERSONNEL ON THE VO-350/355 UNIT ALWAYS MAKE SURE THAT THE TRUCK AND THE AERIAL LIFT HAVE NOT BECOME ELECTRICALLY ENERGIZED. CONTACT MADE BY RESCUERS FROM THE GROUND WITH AN ENERGIZED UNIT COULD CAUSE DEATH OR SERIOUS INJURY.*

CONTROL SELECTOR (Platform Override) -

When a situation requires the upper controls be overridden (i.e. an injured operator in the platform) use the control selector to select the lower controls for operation of the lift. This will render the upper controls inoperable and the lower controls can be used to lower the operator to the ground.

BLEEDER PORTS - If the hydraulic system becomes inoperable with an operator aloft, bleeder ports on the cylinders (Figure 5.2 and 5.3) can be used to lower the booms and return the operator to the ground. Qualified personnel at the site are responsible for selecting the path of boom descent. The unit may be equipped with two different type of bleeder ports. Refer to Figure 5.1 for identification and proper procedures for loosening the bleeder ports. Be prepared for a flow of hot oil escaping around the bleeder port and step away from the boom path of descent. The speed at which the lower boom drifts down depends on the rate of oil loss.

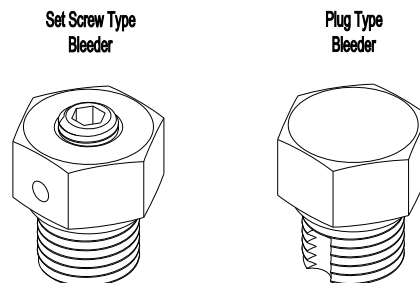

Bleeder Ports
Figure 5.1

Set Screw Type Bleeder - Turn the set screw slowly using an Allen wrench to release load. Do not turn the body. Oil is released from the hole on the side of hex body.

Plug Type Bleeder - Turn the entire plug slowly using a wrench to release load. Do not remove the plug. Oil is released from the notch in the threads. Torque to 15-20 ft-lbs. after use.

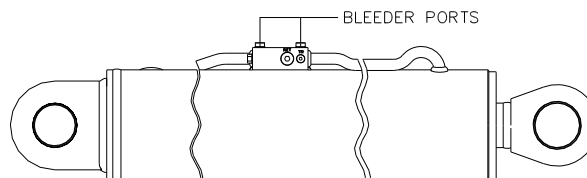

Bleeder Ports On The Upper Boom Cylinder
Figure 5.2

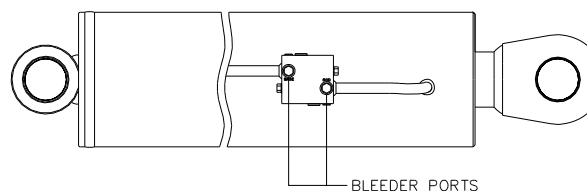

Bleeder Ports On The Lower Boom Cylinder
Figure 5.3

MANUAL ROTATION - If the hydraulic system becomes inoperable the lift rotation system can be operated manually. Before manual rotation is attempted, remove the plugs from the motor test ports on the dual counter-balance valve manifold located on the rotation motor (Figure 5.4). This allows oil to be piloted during rotation of the lift. Be prepared for a flow of oil escaping from the motor test ports. Rotate the lift by using a 7/8 in. hex socket, an extension, and a ratchet to rotate the gearbox input shaft accessible through the access hole on the turret.

Actuating the lower rotation control lever will reduce the effort required to rotate the lift.

If manual rotation is used, test port plugs must be replaced on counter-balance valve manifold. See “Responsibilities after Emergency Operation” at the end of this chapter.

After manual rotation is completed, it is extremely important to close the bleeder ports and refill the reservoir with a suitable hydraulic oil. Operate the aerial lift from the lower controls for several cycles to fill the hydraulic components with oil and then refill the oil reservoir if required.

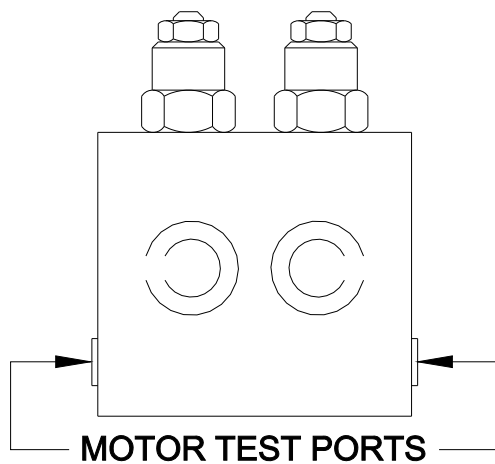

Test Port Plugs
Figure 5.4

OUTRIGGER BOOM INTERLOCK MANUAL OVERRIDE – In the event of diverter valve failure, and the lift becomes inoperable with an operator aloft, the outrigger boom interlock selector can be overridden to lower the booms and return the operator to the ground. To activate the manual override, locate the solenoid operated 3-way valve, usually in the pedestal. On the end of the valve, there is a small tab (Fig. A) which can be pressed with a small screwdriver, capscrew, etc. With this tab pressed down, hydraulic flow will be diverted from the outriggers to the lift. Another operator can then operate the lower controls to lower the booms.

⚠ WARNING: USE OF MANUAL OVERRIDE TO OPERATE THE LIFT WITHOUT THE OUTRIGGERS DEPLOYED CAN RESULT IN SERIOUS INJURY OR DEATH.

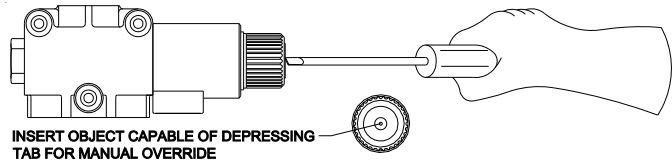

OUTRIGGER BOOM INTERLOCK SELECTOR VALVE MANUAL OVERRIDE ON SOLENOID OPERATED 3-WAY VALVE

Figure A

Outrigger Boom Interlock Manual Rotation
Figure 5.5

BACKUP PUMP (Optional) - The backup pump system provides hydraulic power from a DC pump-motor for emergency lowering of the lift in the event of a prime power source failure. (Refer to Section 4 for operating procedure).

ENGINE START/STOP CONTROL - The engine start/stop control can be used for emergency operation if the prime power source fails. Operate the aerial lift only while attempting to stow the booms. (Refer to Section 4 for operating procedure).

INJURED OR INCAPACITATED OPERATOR - If the operator is unable to operate the aerial lift, determine if any damage has occurred to make the lift inoperable. If the aerial lift is operable, move the platform away from the danger and into the shortest clear path of descent to get the operator on the ground. If an equipment defect is suspected, do **not** allow anyone to enter the platform. If the situation allows safe operation from the lower controls, override the upper controls and carefully lower the platform to the ground. See the title, “Control Selector” near the beginning of this chapter for specific instructions on overriding the upper controls. If the aerial lift is not operable, use another aerial lift to rescue the operator from the platform or consider one of the other emergency procedures presented in this chapter.

HYDRAULIC LINE FAILURE - Hydraulic line failure during aerial lift operation presents numerous hazards. Be aware that a hydraulic oil mist caused by a leak or hydraulic line failure is conductive even though a non-conductive oil is used.

⚠ DANGER: AVOID HIGH PRESSURE HYDRAULIC OIL SPRAY. THIS SPRAY OR MIST CAN PUNCTURE OR BECOME EMBEDDED BENEATH THE SKIN OR CONTAMINATE THE EYES. THESE CONDITIONS REQUIRE IMMEDIATE MEDICAL ATTENTION.

A hydraulic line leak can create a vacuum in a closed line; in some cases, the 'vacuum' may become conductive. Furthermore, most hydraulic oils are flammable. Another danger to personnel is bodily contact with hot oil. The operator and the ground crew must be alert for these hazards to avoid injury.

⚠ DANGER: AVOID ANY CONTACT BETWEEN HYDRAULIC OIL AND SOURCES OF HIGH HEAT OR OPEN FLAMES. DEATH OR SERIOUS INJURY MAY RESULT FROM A FIRE.

⚠ WARNING: CONTACT WITH HOT HYDRAULIC OIL MAY CAUSE SERIOUS BURNS WHICH REQUIRE IMMEDIATE MEDICAL ATTENTION.

A quick response to **hydraulic line failure** is important if the operator is to be safely removed from the platform. The examples below describe some emergency operating procedures for some specific types of hydraulic line failures.

1. The aerial lift uses holding valves to lock the position of the booms in the event of a complete hydraulic line failure.
2. If there is a continuous loss of hydraulic oil from the aerial lift, operate the hydraulic power source only while attempting to stow the aerial lift to conserve the hydraulic oil. If operation of any aerial lift function is not possible, then use the bleeder ports and the manual rotation procedure described earlier.
3. A hydraulic line failure between the upper and lower controls may temporarily allow continued operation of the aerial lift. The rate of the hydraulic oil loss can be reduced by overriding the upper controls and operating the aerial lift with the lower controls. If only part of the hydraulic oil is lost use of the aerial lift or some functions may be possible. If the oil supply is depleted, discontinue operation of the hydraulic power source to minimize damage to the hydraulic pump. If aerial lift functions are inoperable, use of the bleeder ports or manual rotation will be required. A quick response to this type of hydraulic line failure can simplify the steps required to lower the platform and remove the operator.

ENGINE FAILURE - If the prime power source fails, the optional backup pump system can be used for emergency operation. If this system is not installed,

use the engine start/stop control to crank the engine as previously explained. The bleeder ports and manual rotation must be used if backup pump and the start/stop system are not installed.

HYDRAULIC PUMP FAILURE - If the primary hydraulic pump fails use the backup pump system, if so equipped. If this feature is not installed, the bleeder ports and manual rotation must be used.

CONTROL VALVE FAILURE - If aerial lift motion cannot be stopped use the emergency stop, upper control override, or engine start/stop control to halt the lift functions.

Upper Control - Push the knob labeled "PUSH FOR EMGY. STOP". When the emergency stop knob is pushed down, the upper controls are inoperable and pressure at the tool ports is relieved.

Lower Controls - The aerial lift may be operated by overriding the upper controls with the control selector.

Engine Start/Stop Control - The engine start/stop control, at the upper, lower, or cab controls, can be used to stop the engine and hydraulic flow to the lift functions.

RESPONSIBILITIES AFTER EMERGENCY OPERATION:

After any emergency situation it is the responsibility of the operator to make sure the aerial lift is repaired and adjusted by the service department before it is used again.

If an equipment defect is suspected, do **not** allow anyone to operate the aerial lift or enter the platform.

If the bleeder ports are used they must be retightened and the hydraulic reservoir must be refilled. The aerial lift must then be operated, from the lower controls, through its full range of motion several times. Check the hydraulic oil reservoir level and refill if necessary.

DAILY VISUAL INSPECTION

This aerial lift is designed to provide years of reliable service with minimum maintenance. A routine preventive maintenance program will assure extended aerial lift service. The operator is responsible for detecting maintenance problems during the daily visual inspection, reporting the need for adjustments or repairs, verifying that maintenance is performed at the suggested intervals, and determining if the aerial lift is in a good, safe operating condition. The importance of accurate maintenance records cannot be over emphasized. In order to judge the condition of the aerial lift, the operator needs to be familiar with the maintenance records of the aerial lift. Refer to the "Maintenance Checklist" in Service Procedures Section of the Service Manual for the suggested interval inspection information. The actual repair or adjustment must be done by a qualified aerial lift mechanic.

Every day the equipment must be thoroughly visually inspected to detect problems before they become serious. During this inspection the operator shall look for anything out of the ordinary. Particular attention must be paid to the following items. The Daily Visual Inspection Checklist included in this section must be followed.

BOLTS - Critical fasteners are identified on the "Critical Fasteners" drawing in this section. All major sections of the **Versalift** are bolted together and it is vital that these bolts remain tight. Visually inspect all the bolts for signs of relative movement. Pay particular attention to the load supporting bolts (rotation bearing bolts, pedestal/subframe mounting bolts, platform rotator bolts). Critical bolts are Torque-Seal marked to provide a quick means of detecting any turning. Do not use the lift if the Torque-Seal mark between the bolt head and mounting surface, are not in alignment. Refer to the Maintenance and Inspection Schedule in Service Procedures Section of the Service Manual for recommended torque procedures and torque chart specifications. Refer to Figure 6.1 and 6.2 for Torque-Seal mark conditions.

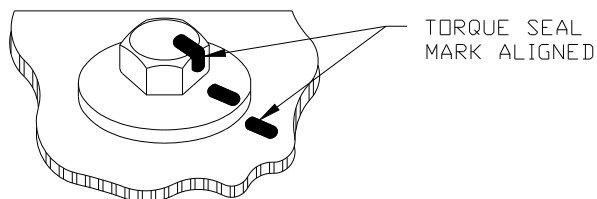

Torque-Seal Mark In Acceptable Condition
Figure 6.1

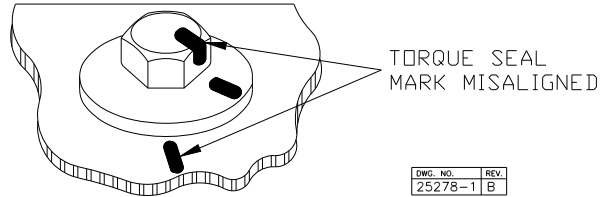

Torque-Seal Mark In Misalignment Condition
Figure 6.2

WELDS - Refer to the "Critical Welds" drawing in this section. All the welds should be inspected for signs of fatigue. Hairline cracks in a weld are a strong indication of weld fatigue. Some critical welds that warrant special attention are where the turret wings are welded to the base plate, the cylinder mounts are welded to the boom, the cylinder mounts are welded to the turret, the knuckle welds on the booms, and the welds on the platform mounting shaft.

HYDRAULIC LINES - Hydraulic lines should be inspected for loose connections and frayed jackets. Carefully examine the hoses especially that portion of the hose subject to flexing and particularly the hoses at the platform.

OIL LEAKS - Oil leaking onto the truck floor or on the ground is a sign of an impending problem. A hydraulic leak will create a slippery surface which is potentially hazardous. When a hydraulic leak is encountered it must be repaired by the proper service personnel and the unit must be cleaned of excess hydraulic oil. If a hydraulic leak is not repaired the oil in the reservoir will be depleted and pump damage may occur.

ELECTRICAL SYSTEM - Inspect electrical system for damaged components. Check for bare electrical wires and remove any trash or debris from around electrical components. Repair all damaged wires and secure any loose electrical components or wires.

VEHICLE TIRES - Check tires for the correct inflation and for damage. Low pressure or damaged tires are unsafe while driving the vehicle or operating the lift.

LOOSE OBJECTS - Inspect the booms for loose objects (tools, spare parts, etc.) that might fall when the booms are elevated.

HYDRAULIC OIL LEVEL - The hydraulic fluid level can be easily checked by monitoring the oil level through the sight gauges. Add hydraulic oil if necessary. Refer to "Hydraulic Oil Recommendations" in Service Procedures Section of the Service Manual for oil recommendations. It is important to maintain

the proper hydraulic oil level because a full reservoir will minimize the operating temperature and, in the event of a hydraulic line leak, a full reservoir gives the operator more time to lower the platform. Caution: do not overfill the oil reservoir.

CONTROLS - Operate all the lift controls through the full range of motion to verify the controls function properly.

LEVELING SYSTEM - The leveling system in the **Versalift** is subject to wear and has a limited life. Failure of the leveling system may cause the platform to tip rapidly. The system is comprised of chains, sprockets, insulator rods, and tensioners. Refer to Parts & Assemblies Section of the Service Manual for these components. For inspection, the access covers must be removed from the lower and upper booms. The leveling system must be inspected every 90 days for proper tension, fatigue, excessive wear, and for rods pulling out of sockets. If these conditions exist they must be repaired by qualified personnel before operation.

An application of lubricant annually will help extend the chain life. A penetrating lubricant designed for chain use, such as Lubriplate "Chain and Cable Spray," should be used.

DECALS - Identification, operational, and instructional decals are installed at numerous locations on the **Versalift**. These decals must be replaced if they become lost, damaged, or illegible. Refer to the "Decal Placement" illustration in this section for a complete decal listing and the locations of all the decals.

FIBERGLASS BOOM - Inspect the fiberglass upper boom and the lower boom inserts for an accumulation of dirt that can impair the insulating value of the fiberglass. The fiberglass outer surface of the booms should be cleaned daily with a lint free cloth. If the fiberglass sections require a more thorough cleaning, Refer to Service Procedure Section, "Care of Fiberglass Booms" of the Service and Installation Manual. Check for any structural damage in the fiberglass such as cracks or gouges. If these conditions exist, they must be repaired by qualified personnel.

PLATFORM - Inspect the platform for cracks in the mounting ribs, floor, and flange around the top. If these conditions exist they must be repaired by qualified personnel before operation.

ROPE - Make a thorough check of the winch rope for abrasive wear, pulled strands, cuts, and other

defects. The rope should be clean and dry. The rope coils should spool evenly on the winch reel. Do not use a rope that has been subjected to shock loads. Replace the winch rope at the first sign of damage or deterioration. Use only non-conductive rope of the size and type specified.

WINCH - Verify that the rope coils are spooling evenly. Check for hydraulic leaks as well as leaks from the winch drive gearbox.

SLOPE INDICATORS - The indicators are installed at several locations on the Versalift chassis. Check that indicators are in place and not damaged. Refer to slope indicator installation in "Parts and Assemblies" Section in the Service Manual.

SAFETY DEVICES - Check visual and audible safety devices for proper operation.

COVERS - Inspect all covers to make sure they are in place, secure and in good condition.

DAILY VISUAL MAINTENANCE AND INSPECTION CHECKLIST AND RECORD
VERSALIFT VO-452/455/460-MHI, SERIAL NO. _____ VEHICLE NO. _____

Fill in date and initial boxes when each check is made. Refer to Daily Visual Inspection in this Operator's Manual for complete description of checks. Additional copies of this form may be obtained from **Time Manufacturing Company**.

DAY	SUN	MON	TUE	WED	THU	FRI	SAT
DATE							
INSPECT BOOMS FOR TRASH & DEBRIS							
CRITICAL FASTENERS							
CRITICAL WELDS							
HYDRAULIC LINES - FRAYED JACKETS							
OIL LEAKS - LOOSE CONNECTIONS							
ELECTRICAL SYSTEM							
VEHICLE TIRES							
LOOSE OBJECTS							
HYDRAULIC OIL LEVEL							
CONTROLS							
LEVELING SYSTEM							
DECALS							
FIBERGLASS BOOM							
FIBERGLASS PLATFORM							
ROPE							
WINCH							
SLOPE INDICATORS							
SAFETY DEVICES							
COVERS							
NOTES:							

DAILY VISUAL INSPECTION



REV.	ERCN NO.	DESCRIPTION	BY	CHKD.	APPR.	DATE
59541		FIRST RELEASE	LBR	D,JH	SRS	10-12-11

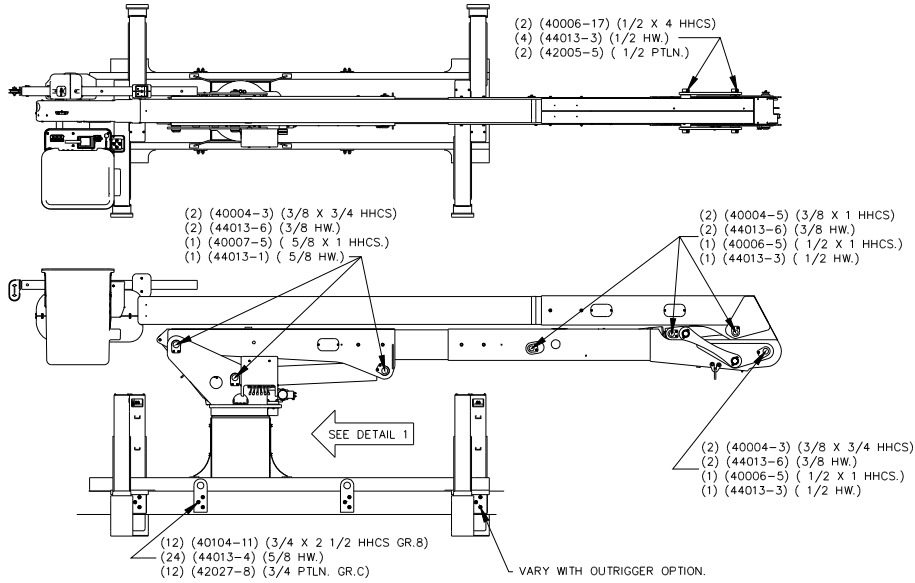

NOTES:

- 1.) ALL FASTENERS THAT ARE STRUCTURAL OR RETAIN ANOTHER STRUCTURAL MEMBER ARE CRITICAL.
- 2.) HEX HEAD BOLTS ARE GRADE 5, NUTS ARE GRADE B, AND WASHERS ARE HARDENED STEEL UNLESS OTHERWISE NOTED.
- 3.) MINIMUM OF TWO THREADS THROUGH ANY LOCKNUT.
- 4.) FASTENER CALLOUTS READ AS FOLLOWS:
(QTY. PER ARROWHEAD) (PART NO.) (DESCRIPTION).
- 5.) TORQUE ALL CRITICAL FASTENERS PER THE TORQUE CHART "TMC-778" IN THE OPERATORS AND SERVICE MANUALS, UNLESS OTHERWISE NOTED.
- 6.) ALL THREADED CRITICAL FASTENERS TO BE MARKED WITH TORQUE SEAL TO PROVIDE INDICATION OF TURNING.
- 7.) ABBREVIATIONS:
HHCS = HEX HEAD CAP SCREW
SHCS = SOCKET HEAD CAP SCREW
BHCS = BUTTON HEAD CAP SCREW
HW = HARDENED WASHER
PTLN = PREVAILING TORQUE LOCKNUT

UNLESS OTHERWISE NOTED:
TOLERANCES: DECIMALS
FRACTIONS ± 1/16 X ± .1
ANGLES ± 1° XX ± .03
XXX ± .005
MACHINED SURFACE FINISHES = 125
PROJECTION OF VIEWS
ALL DIMENSIONS ARE IN INCHES
THIS PRINT CONTAINS CONFIDENTIAL INFORMATION AND IS SOLE PROPERTY OF TIME MANUFACTURING, AND IS NOT TO BE DISCLOSED, COPIED, OR REPRODUCED WITHOUT EXPRESSED PERMISSION OF TIME MANUFACTURING.

TIME MANUFACTURING COMPANY WACO TEXAS	DWN. BY	DATE	TITLE
	LBR	10-12-11	CRITICAL FASTENERS
MATERIAL	SIZE	SCALE	V0452/455/460MHI
	A	1=55	
FINISH	EST WT #	MANUAL	DWG. NO.
			1000095-DWG
SHEET		1 OF 2	

REV.

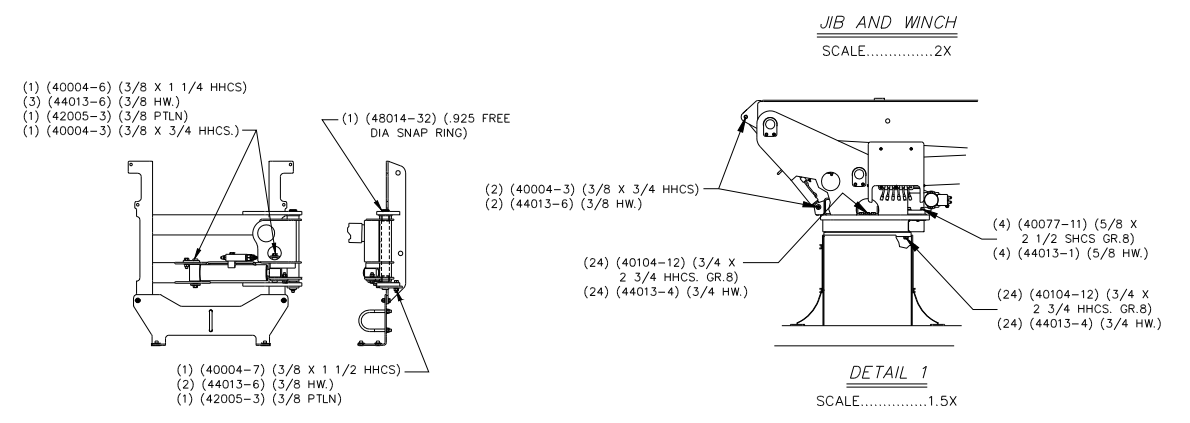
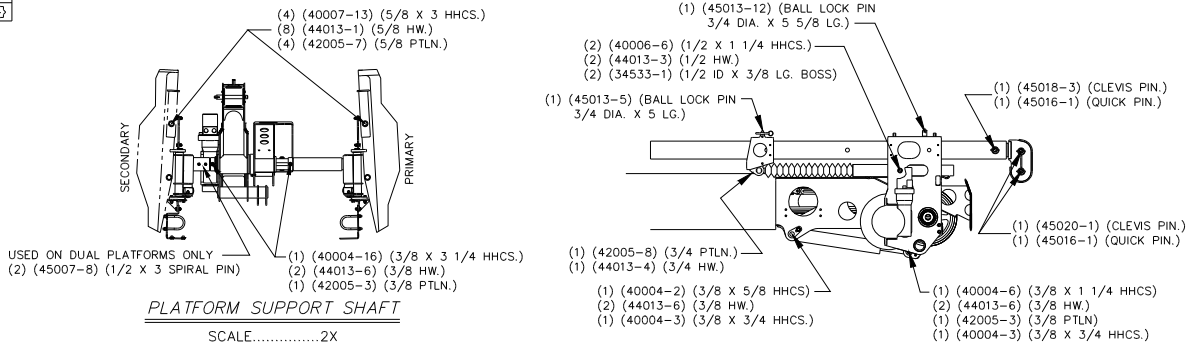

UNLESS OTHERWISE NOTED:
TOLERANCES: DECIMALS
FRACTIONS ± 1/16 X ± .1
ANGLES ± 1° XX ± .03
XXX ± .005
MACHINED SURFACE FINISHES = 125
PROJECTION OF VIEWS
ALL DIMENSIONS ARE IN INCHES
THIS PRINT CONTAINS CONFIDENTIAL INFORMATION AND IS SOLE PROPERTY OF TIME MANUFACTURING, AND IS NOT TO BE DISCLOSED, COPIED, OR REPRODUCED WITHOUT EXPRESSED PERMISSION OF TIME MANUFACTURING.

TIME MANUFACTURING COMPANY WACO TEXAS	DWN. BY	DATE	TITLE
	LBR	10-12-11	CRITICAL FASTENERS
MATERIAL	SIZE	SCALE	V0452/455/460MHI
	A	1=55	
FINISH	EST WT #	MANUAL	DWG. NO.
			1000095-DWG
SHEET		2 OF 2	

DAILY VISUAL INSPECTION



REV.	ERCN NO.	DESCRIPTION	BY	CHKD.	APPR.	DATE
59541		FIRST RELEASE	LBR	D.JH	SRS	10-12-11

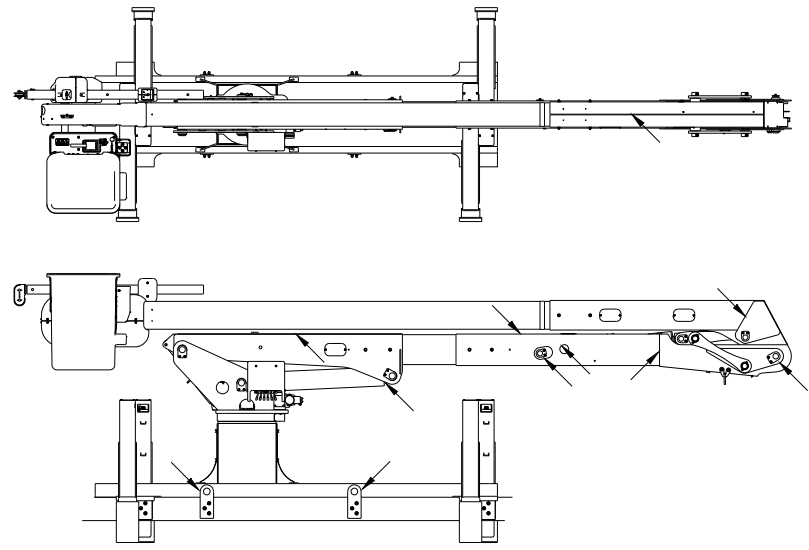

- NOTES:
- 1.) CRITICAL WELDED JOINTS TO BE INSPECTED ARE INDICATED BY ARROWS. THE JOINTS MAY INCLUDE WELDS ON BOTH SIDES OR INSIDE AND OUTSIDE AS APPLICABLE.
 - 2.) THERE ARE ADDITIONAL CRITICAL WELDS ON THE MOUNTING HARDWARE AND OUTRIGGERS.
 - 3.) ALL WELDED PIN RETAINERS ARE CRITICAL WELDS.
 - 4.) ANY STRUCTURAL WELD FOUND DEFFECTIVE SHOULD BE CORRECTED AND NEVER IGNORED. WELDS MUST BE REPAIRED IN ACCORDANCE WITH ANSI A92.2 REQUIREMENTS. CONSULT FACTORY FOR MATERIAL SPECIFICATIONS AND PROPER WELDING SPECIFICATIONS.

<small>UNLESS OTHERWISE NOTED: TOLERANCES: DECIMALS FRACTIONS ± 1/16 .xx ± .03 ANGLES ± 1° .xxx ± .005 MACHINED SURFACE FINISHES = 125 PROJECTION OF VIEWS = 1st ALL DIMENSIONS ARE IN INCHES</small>		MANUFACTURING COMPANY WACO TEXAS	DWN. BY	DATE	TITLE
			LBR	10-12-11	CRITICAL WELDS
<small>THIS PRINT CONTAINS CONFIDENTIAL INFORMATION AND IS SOLE PROPERTY OF TIME MANUFACTURING, AND IS NOT TO BE DISCLOSED, COPIED, OR REPRODUCED WITHOUT EXPRESSED PERMISSION OF TIME MANUFACTURING.</small>	MATERIAL	FINISH	EST WT #	MANUAL	VO452/455/460MHI
			SHEET	DWG. NO.	1 OF 2

REV.
59541

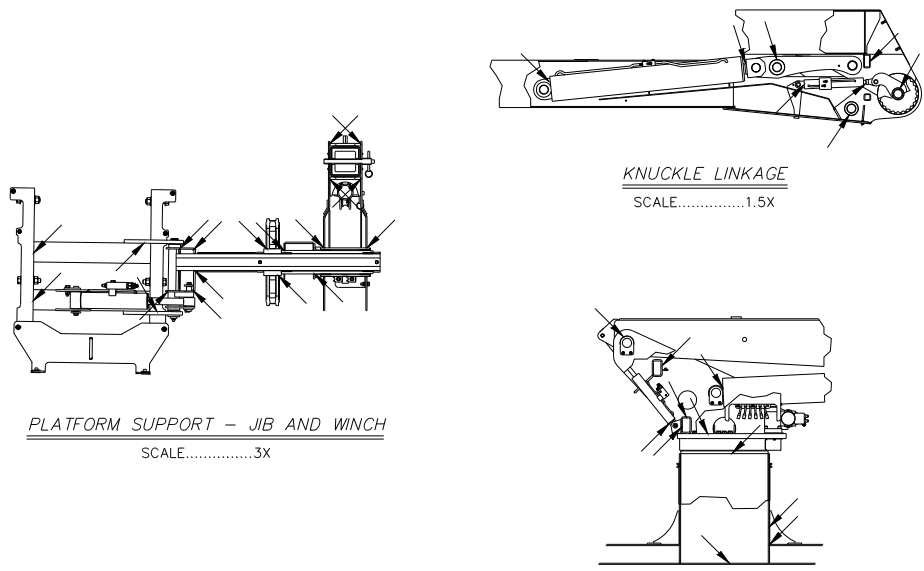

PLATFORM SUPPORT - JIB AND WINCH
SCALE.....3X

KNUCKLE LINKAGE
SCALE.....1.5X

TURRET AND PEDESTAL
SCALE.....1.5X

<small>UNLESS OTHERWISE NOTED: TOLERANCES: DECIMALS FRACTIONS ± 1/16 .xx ± .03 ANGLES ± 1° .xxx ± .005 MACHINED SURFACE FINISHES = 125 PROJECTION OF VIEWS = 1st ALL DIMENSIONS ARE IN INCHES</small>		MANUFACTURING COMPANY WACO TEXAS	DWN. BY	DATE	TITLE
			LBR	10-12-11	CRITICAL WELDS
<small>THIS PRINT CONTAINS CONFIDENTIAL INFORMATION AND IS SOLE PROPERTY OF TIME MANUFACTURING, AND IS NOT TO BE DISCLOSED, COPIED, OR REPRODUCED WITHOUT EXPRESSED PERMISSION OF TIME MANUFACTURING.</small>	MATERIAL	FINISH	EST WT #	MANUAL	VO452/455/460MHI
			SHEET	DWG. NO.	2 OF 2



DAILY VISUAL INSPECTION

REV

DASH NO.	DESCRIPTION	CODE
-1	DECAL PLACEMENT	DE-1341-6

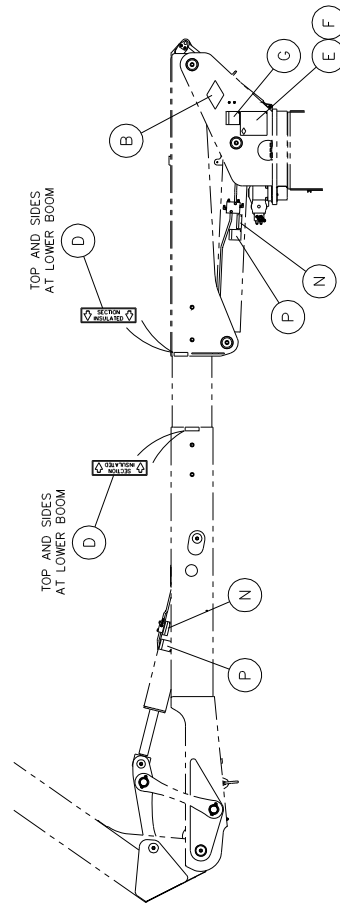
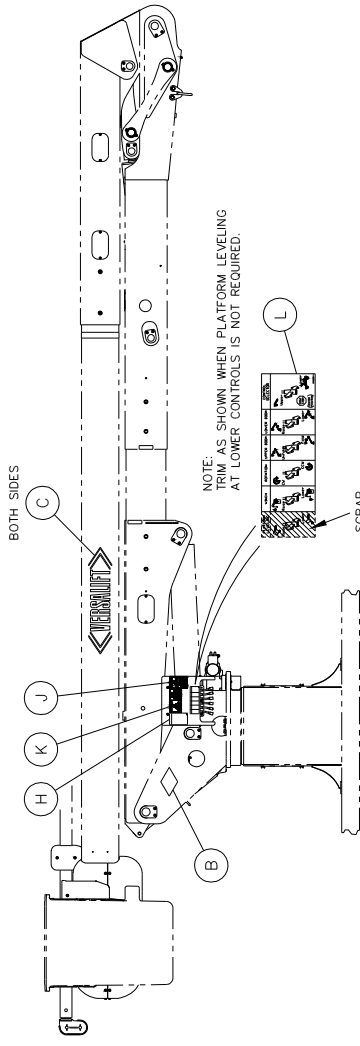
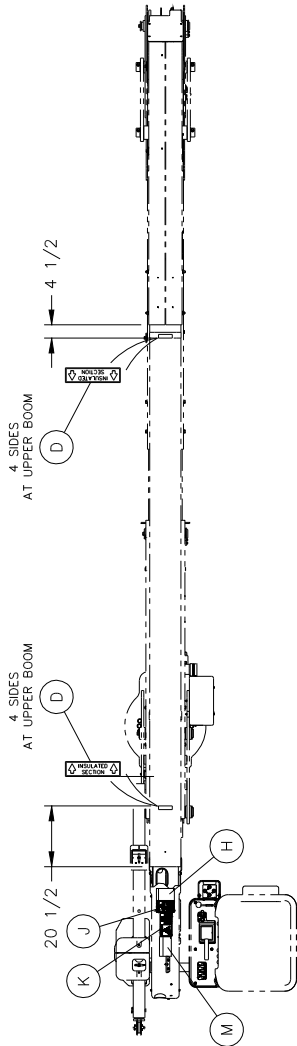

* THESE ITEMS TO BE SHIPPED LOOSE.

QTY.	ITEM	DESCRIPTION/LOCATION
1	E	LOCATED ON STREET SIDE OF TURRET
1	F	LOCATED ON STREET SIDE OF TURRET
4	Q	LOCATED AT EACH CORNER OF TRUCK
1	R	LOCATED NEAR SYSTEM RELIEF VALVE

QTY.	ITEM	PART NO.	DESCRIPTION
* 1	R	7584-1	DECAL - RELIEF ADJUSTMENT
* 4	Q	4542-2	DECAL - DANGER ELECTROCUTION
2	P	7500-1	DECAL - HOLDING VALVE
2	N	15732-1	DECAL - EMERGENCY LOWERING
1	M	11446-1	DECAL - WIND DANGER
1	L	1006828-1	DECAL - LOWER CONTROL
2	K	4542-12	DECAL - DANGER QUALIFIED OPERATOR
2	J	4542-4	DECAL - DANGER ELECTROCUTION
2	H	4542-5	DECAL - CAUTION OPERATION
1	G	12337-1	DECAL - OWNERSHIP TRANSFER
* 1	F	1006486-1	DATA PLATE
* 1	E	1006487-1	DATA PLATE BACKING
14	D	5098-1	DECAL - INSULATED SECTION
2	C	4541-2	DECAL - VERSALIFT LARGE
2	B	426-011	DECAL - VERSALIFT DIAMOND
2	A	1006873-DWG	DECAL PLACEMENT

UNLESS OTHERWISE NOTED:
 TOLERANCES: DECIMALS
 FRACTIONS: 1/16
 ANGLES: ± .03
 UNLESS OTHERWISE NOTED
 MACHINED SURFACE FINISHES: .003
 PROJECTION OF WELDS: .015
 THIS DRAWING CONTAINS CONFIDENTIAL INFORMATION AND IS THE PROPERTY OF TIME MANUFACTURING. IT IS TO BE DISCLOSED, COPIED, OR REPRODUCED WITHOUT THE WRITTEN PERMISSION OF TIME MANUFACTURING.

LIST OF MATERIAL			
QTY.	ITEM	PART NO.	DESCRIPTION
		MANUFACTURING COMPANY	TIME
		WACO TEXAS	DTG 5/9/16
			SCALE
			B 1=40
			EST WT # MANUAL
			VO452/455/460MHI
			SHEET
			1 OF 1
			DWG. NO. 1006873-DWG

