

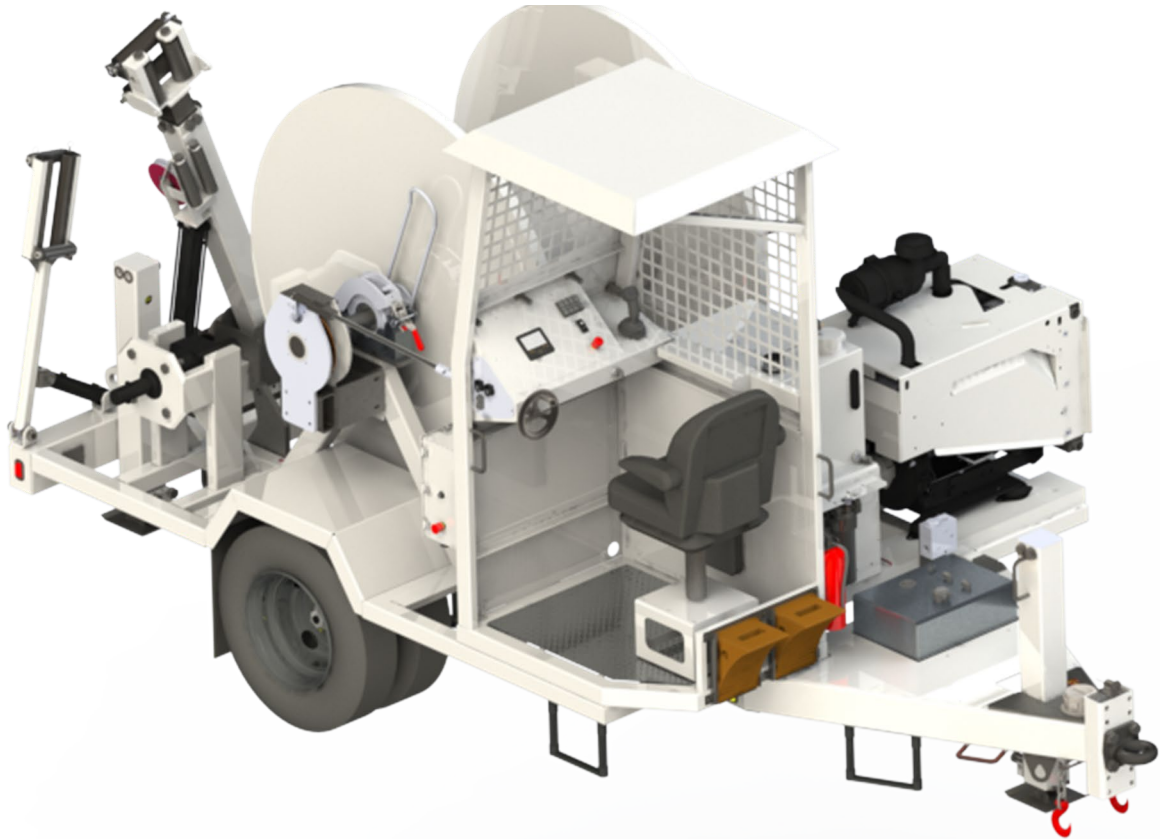

SHERMAN+REILLY™



Sherman + Reilly™ Revolution Series

PT-3000 Puller Tensioner Operator's Manual

SHERMAN + REILLY™
Revolution Series
PT-3000 Puller Tensioner
OPERATOR'S MANUAL
©2018 by Sherman + Reilly Inc.
Revision B August 2018

SHERMAN + REILLY™
Revolution Series
PT-3000 Puller Tensioner
OPERATOR'S MANUAL

©2018 by Sherman + Reilly™ Inc.

Important Safety Notice

Before using any Sherman + Reilly™ equipment, operators must read and understand all procedures and safety instructions. Note all safety information and specific safety requirements as explained in this manual.

Failure to follow these instructions could result in damage to the machine, serious personal injury, or death.

Advertencia

Por favor, lea atentamente todas las instrucciones operacionales y de seguridad antes de operar esta maquinaria. Si no entiende las instrucciones, por favor consulte a su supervisor antes de utilizar esta maquinaria.

El uso inadecuado de estas instrucciones puede resultar en lesiones graves o en muerte.

Save this operator's manual for future reference.

This material is copyrighted and proprietary to Sherman + Reilly™ Inc. and is not to be reproduced, used, or disclosed except in accordance with express written permission from Sherman + Reilly™ Inc. Information is provided for the purpose of product usage and maintenance descriptions only. The descriptions and specifications in this manual are subject to change without notice, and to the best of our knowledge, are accurate at the time of printing. The information contained may not be specific to all models or units, and must not be construed as warranted characteristics in the legal sense. The information does not relieve users from the duty of conducting their own inspections and evaluations. The information contained represents the best practices for the safest use and maintenance of the machine/unit, and does not cover every situation. With regard to situations not covered in this manual, the operator is responsible to ensure the safe operation of the machine and should ask questions or make inquiries if uncertainty exists prior to the operation of the machine or unit. Sherman + Reilly™ Inc. reserves the right to continually improve and expand our product line. It is our policy to improve our products whenever it is possible and practical to do so. We reserve the right to make changes or improvements at any time without incurring any obligation to install such changes on products previously sold. As our products are subject to continual improvement, we reserve the right to amend the product specifications, maintenance steps, and all information contained in this manual. Some product improvements may have taken place after this manual was published.

Communication with the Manufacturer

For information on Sherman + Reilly™ products, contact us by phone at **(423) 756-5300** or **800-251-7780** or via email at help@sherman-reilly.com or at 400 W. 33rd Street, Chattanooga, TN 37410; www.sherman-reilly.com.

NOTE: Product images shown are for illustration purposes only and may not be an exact representation of your product. Actual product may vary due to continual product enhancement and improvement.

Table of Contents

IMPORTANT SAFETY NOTICE	3
COMMUNICATION WITH THE MANUFACTURER	3
1 INTRODUCTION.....	1
1.1 TERMS OF USE	1
2 SAFETY	2
2.1 HAZARD OVERVIEW	2
2.2 COMMON ISO SYMBOLS:	3
2.3 OPERATOR SAFETY PRECAUTIONS	4
2.4 EMPLOYER SAFETY PRECAUTIONS	5
2.4.1 <i>Chemical Safety</i>	6
2.4.2 <i>Temperature Limits for Hydraulic Oil</i>	6
2.4.3 <i>Before Starting Operations</i>	7
2.4.4 <i>Understand the Machine</i>	7
2.4.5 <i>Preparations for Safe Operation</i>	7
2.4.6 <i>Pre-Towing Checklist</i>	10
2.4.7 <i>In the Event a Fire Occurs</i>	11
EMERGENCY STOP PROCEDURE	11
2.4.8 <i>Unauthorized Modifications</i>	13
2.4.9 <i>Precautions When Running Engine Inside Building</i>	13
2.4.10 <i>Investigate and Confirm Jobsite Conditions</i>	13
2.4.11 <i>Precautions When Working on Loose Ground</i>	13
2.4.12 <i>Positioning the Machine</i>	14
3 CONTROLS.....	15
3.1 GENERAL OVERVIEW	15
3.2 SPECIFICATIONS.....	16
3.3 TERMS TO KNOW	17
3.4 OPERATOR CONTROLS	18
3.4.1 <i>Control Panel on the Unit</i>	18
4 HANDLING AND OPERATION	20
4.1 PRE-OPERATION INSPECTION	20
4.2 START UP AND SET UP PROCEDURE	22
4.3 SYSTEM CONTROL SCREEN DESCRIPTIONS	23
4.3.1 <i>Main Screen</i>	23
4.3.2 <i>Engine Information Screen</i>	24
4.3.3 <i>Engine Indicators</i>	24
4.3.4 <i>Hydraulic Information Screen</i>	25
4.3.5 <i>Set Up Screen – Security Level 0</i>	26
4.3.6 <i>Automatic Control System Shutdown</i>	27
4.3.7 <i>Controller Communications Error Screen</i>	27
4.3.8 <i>Error Messages</i>	27
4.3.9 <i>Engine Error Codes</i>	27
4.3.10 <i>DPF and Engine Indicators</i>	28
4.4 ENGINE THROTTLE CONTROL	29
4.1 JACK CONTROLS	29
4.2 PMTA BOOM CONTROL.....	30
4.3 BRAKE OPERATION	31
4.4 HYDRAULIC MANUAL OVERRIDE	32
4.5 HYDRAULIC WARM-UP.....	32
4.6 DIESEL PARTICULATE FILTER (DPF) RE-GENERATION INFORMATION.....	33
4.7 REEL REMOVAL AND INSTALLATION	34
4.8 PAYOUT OPERATIONS – PULL MODE.....	36

4.9	PAYOUT OPERATIONS – NON-POWERED	38
4.9.1	Manual Payout Brake	38
4.9.2	Non-powered Walk-off	39
4.10	PULLING	40
4.10.1	Tension	42
TENSIONING		42
4.10.2	Spider System	44
4.11	UNDERGROUND CONNECTORS	45
4.12	UNDERGROUND PULLING	46
4.13	POST-OPERATION INSPECTION CHECKLIST	48
5	TROUBLESHOOTING	49



1 Introduction

1.1 Terms of Use

It is important that every machine is operated in a safe manner. To properly, safely operate this machine, it is required that operators and service people read and understand the information in this and the engine manufacturer's manual. ANYONE working around the machine should read the safety precautions in the manuals. Be aware each warning and precaution is to help protect against injury. Taking unnecessary risks and ignoring warnings is the primary cause of personal injury and fatal accidents in the work place. If you have any questions regarding operation or safety of a procedure or situation, contact the Sherman+ Reilly™ Customer Service Manager at 800-251-7780 or via email at help@sherman-reilly.com

Publication of this manual and the safety precautions in it does not in any way represent an all-inclusive list. It is the operator's responsibility to make sure the machine is operated in accordance with all state and local safety requirements and codes, including all applicable OSHA- (Occupational Safety and Health Administration) and EPA- (Environmental Protection Agency) regulations, as well as ANSI- (American National Standards Institute) accredited standards.

Should a problem or unsafe condition arise, shut the machine down using the normal shut-down procedure. In the event of an emergency, use the emergency stop procedure described in this manual, and then notify the proper authorities or follow your employer's prescribed procedure for an emergency situation.

Sherman + Reilly™ strongly recommends that only persons who have a full understanding of the provided manual and who are knowledgeable in the use of overhead line pulling and tensioning machines, including all applicable laws, regulations, and safety standards, be allowed to operate this machine. There are significant hazards inherent to the use of this machine; therefore, all operators should be educated on all functions, procedures, and safety measures outlined in this manual prior to their use or maintenance of this machine.

Sherman + Reilly™ strongly recommends that only personnel that are literate in the English language and who verbally understand the English language be considered as operators or service personnel for this machine.

Sherman + Reilly™ also recommends following applicable guidance published by the Institute of Electrical and Electronics Engineers (IEEE), and specifically IEEE Standard 524 – Guide to the Installation of Overhead Transmission Line Conductors (IEEE 524-2003 or subsequent).

This manual was prepared to help the operator use and service the machine in a safe manner. Responsibility for safety during operation and service rests with the person(s) performing the work. Being alert of surroundings and observing all safety precautions, and all rating requirements and standards is required to help reduce the possibility of an accident. This manual is of no value if the operator does not read and understand the instructions and precautions- before starting or trying to operate the machine. The operator must be aware of the machine's capacities and limitations. It is the operator's responsibility to watch for situations and conditions which could affect the normal performance of the machine and the safety of the operating/work environment.

Sherman + Reilly™ Pullers are powered, hydraulically actuated machines. This machine has variable speed and line tension controls; however, if tensioning multiple conductors using a running board, the total line pull applied from all conductors must not exceed the capacity of the machine.

2 Safety

2.1 Hazard Overview

Familiarize yourself with the following symbols before operating machinery.

These safety alert symbols are used to alert you to potential hazards.

Please pay attention to all safety warning labels and information placards posted on the machine, components, and trailer assembly. These labels and placards are provided to assist in identifying areas containing potential hazards while also providing information regarding equipment specifications and limitations. Please see below for examples:

Warning Terms: signal words in this manual that call the operator’s attention to safety concerns.

WARNING indicates the information relates to a specific immediate hazard or unsafe practice which, if disregarded, could result in personal injury or death.

DANGER indicates the information relates to a specific immediate hazard which, if disregarded, will result in severe personal injury or death.

NOTE indicates the information is important to the correct operation or maintenance of the machine.

CAUTION indicates the information pertains to a potential hazard or unsafe practice which, if disregarded, may result in minor personal injury or equipment damage.

2.2 Common ISO Symbols:

Not all symbols apply to all machines



High voltage hazard



Eye and/or Ear Hazard



Electrical shock hazard



Risk of Explosion Hazard



Pinch point and/or entanglement hazard



Toxic Hazard



Cutting and/or crushing hazard



Flammable Material Hazard



Crushing of body hazard



Automatic Start-Up Hazard



Crushing of Toes or Foot Hazard



Carcinogen Hazard



Hot Surface Hazard

2.3 Operator Safety Precautions

- Do not attempt to operate any Sherman + Reilly™ equipment without proper instruction, including reading and understanding the provided manual.
- Do not place any part of the body into a potential pinch point. The machine should be turned off and locked out in accordance with OSHA regulations before attempting to correct a problem, work on the machine, or perform preventive maintenance.
- Obey and enforce all warnings including OSHA requirements and ANSI standards.
- Never allow anyone to ride on the unit while it is being towed.
- Always wear proper safety equipment as required by employer.
- Never bypass safety switches or operate equipment with faulty safety devices.
- Be sure all guards and access covers are in place and secured when the machine is being operated.
- Be aware of people in the work area who may be at risk during operation.
- Know all emergency shutdown procedures.
- Do not obstruct controls or fire extinguisher and make sure fire extinguisher is fully charged.
- Never operate equipment while under the influence of any substance which could impair ability or judgment.
- Do not operate equipment if work ability is impaired by fatigue, illness, or other causes.
- Always use employer approved grounding procedures when operating the machine.
- Never use hands to check for hydraulic system leaks. Hydraulic fluid escaping under pressure can cause personal injury.
- Avoid contact with pumps, cylinders, hoses, engine components, and exhaust system.
- Do not refuel unit while the engine is running or hot.
- Keep all body parts, to include head and limbs, away from all moving parts.
- Refer to engine manufacturer's manual for all additional safety precautions which relate to engine operation and service.
- Know location and function of all controls, gauges, instruments, and protective devices.
- Never use unit to tow or winch another vehicle.
- Never use controls or hoses for hand holds.
- Do not exceed unit specifications and limitations, to include weight.
- Know where to get help in the event of an emergency or injury.
- When towing this machine/unit trailer, the driver should use caution and adjust speed based on road, weather, and terrain conditions, as well as applicable laws and speed limits.
- Do not make physical contact with rope or cable as it enters or leaves the machine or drum.
- To prevent the possibility of electrocution, do not enter or leave the unit while it is operating or allow anyone to touch or lean on the machine when in use.
- Avoid direct inhalation of engine exhaust gases.

2.4 Employer Safety Precautions

This guideline is intended to assist owners, employers, job site supervisors, and operators in ensuring that the equipment is operated in a safe manner. Each job site may have additional situations and conditions which need consideration. Information in this manual applies to all the operators charged with the use and/or maintenance of the machine. This manual is not a training manual. This manual must be kept with the machine for the entire life the machine in order to be available to all potential users and operators. This manual should be kept in a sheltered dry place.

Monitor the operators to be sure they observe and practice safety procedures and operate the support equipment as outlined in this manual.

Establish a regular inspection program which includes malfunction reports, inspection, and service records. This inspection should cover the machine condition, adjustment, and ensure all safeguards are in place and functional. Additionally, all pre/post-operation inspections should be conducted at prescribed intervals.

Make sure that any malfunction or breakdown affecting the safe operation of the equipment is properly corrected or repaired before returning the machine to service.

The employer must provide training and instruction in chemical safety and safe methods of work before assigning workers to operate, service, or repair the machine and equipment. A record of training dates, employee names, and level of training shall be maintained. Only persons who have a full understanding of the provided manual- (*provided in English only*), and who are competent in the use of overhead pulling and tensioning machines; to include all applicable laws, regulations, and safety standards, should be allowed to operate this machine. There are significant hazards inherent to the use of this machine, therefore all operators should be educated on all functions, procedures, and safety measures outlined in this manual- prior to their use or maintenance of this machine.

Employer must utilize a lock-out/tag-out procedure which complies with OSHA Standard, Part 1910.147, Title 29 of the Code of Federal Regulations or subsequent. This procedure must include control of all keys.

The employer should specifically inspect all safety equipment and protective devices on the equipment to ensure they are not bypassed or disabled. Operation of equipment should not be permitted unless all safety devices are in place and functional. The employer should meet all appropriate information dissemination and protection requirements for the workers.

Operators and maintenance/service personnel should take appropriate precautions, to include wearing all (PPE)-Personal Protection Equipment, prior to the operation, maintenance, or service of the machine.

Operators should wear suitable clothing to reduce the possibility of entanglement in the machines moving parts. Operators should not wear chains or other jewelry for the same reason.

2.4.1 Chemical Safety

Exposure to chemicals during normal operation of the machine is limited; however, chemical exposure may be encountered through preventive maintenance and repair. Operators and maintenance/service personnel should take appropriate precautions, to include wearing all (PPE)-Personal Protection Equipment, prior to the operation, maintenance, or service of the machine. All Material Safety Data Sheets (MSDS's) or Safety Data Sheets (SDS's) for OEM chemicals present upon initial manufacture/shipment of machine can be made available upon request to Sherman + Reilly™.

Any additional chemicals introduced to the machine or used in conjunction with maintenance or repair of the machine are required by federal regulations to have a MSDS/SDS available, and are the responsibility of the operator's employer or the organization providing the maintenance. All chemical handling and disposal should be done in accordance with environmental, federal, state, and local laws and regulations. Sherman + Reilly™ is not liable for the mishandling, misuse, or improper disposal of chemicals, with regard to the use or maintenance of Sherman + Reilly™ machines or equipment.

All responsibilities, including but not limited to: handling and disposal of chemicals, availability and maintenance of MSDS's/SDS's, labeling of chemical containers, and training of employees and operators, should be fulfilled in accordance with the Hazard Communication Act, Hazardous Materials Transportation Act, Occupational Safety and Health Administration's Hazard Communication Standard- (29 CFR) Part 1910.1200, and all applicable Environmental Protection Agency Standards and Regulations- (*additional standards may apply*). For further information on safety standards regarding chemicals see OSHA and EPA websites.

2.4.2 Temperature Limits for Hydraulic Oil

WARM-UP HYDRAULIC FLUID.

For safe operations, it is recommended that the hydraulic fluid be allowed to warm-up prior to use. Sherman + Reilly™ units ship with ISO 32 hydraulic fluid. Cold hydraulic fluid can damage the machine.

NOTE: This blue temperature message on the System Control Panel indicates that the oil temperature is below 60 ° F (16 °C). It will disappear once the hydraulic oil exceeds 60 °F (16 °C).



The current temperature of the hydraulic oil can be viewed on the Hydraulic Information Screen.

2.4.3 Before Starting Operations

- Only trained and authorized personnel can operate and maintain the machine.
- Follow all safety, precautions, and instructions in this manual when operating or performing inspection or maintenance on the machine.
- If you are not feeling well, or if you are under the influence of alcohol or medication, your ability to safely operate or repair your machine may be severely impaired, putting yourself and everyone else on your job site in danger.
- When working with another operator if with the person on the worksite traffic duty, discuss the content of the operation beforehand and use the determined signals when performing the operation.

2.4.4 Understand the Machine

- Before operating the machine, read this manual thoroughly. If there is any place in this manual that you do not understand, ask the person in charge of safety for explanation.
- If you find any problem in the machine during operation or maintenance (noise, vibration, smell, incorrect gauges, smoke, oil leakage, etc., or any abnormal display on the warning devices or monitor), report the problem(s) to the person in charge and take the necessary action. Do not operate the machine until the problem has been corrected.

2.4.5 Preparations for Safe Operation

Preparations for Safety Related Equipment

- Be sure that all guards, covers, and safety devices are in their proper position. Repair them immediately if they are damaged.
- Understand the application of safety-related devices and use them properly.
- Never remove any safety-related devices. Always keep them in good operating condition.

Wear Well-Fitting Cloths and Personal Protective Equipment (PPE)

- Do not wear loose clothes or any accessories that could catch the control levers or protruding parts, and could cause the machine to engage unexpectedly.
- Always wear appropriate PPE: hard hat, safety shoes; protective eyeglasses, ear plugs, gloves, and/or face shield, depending on the work.
- Long hair hanging down could become entangled in the machine. Tie the hair up and be careful that it is not caught in the machine.
- Check that all personal protective items function properly before using them.

Keep the Machine Clean

- Always keep the machine clean. If you get on or off the machine or perform inspection and maintenance on the machine with mud or oil on your footwear or hands or on the machine, you may slip and fall. Wipe off any mud or oil from the machine.
- If water gets into the electrical system, it could cause systems malfunctions which could cause the unit to engage unexpectedly and could cause serious personal injury or death. When washing the machine with water or steam, do not allow the water or steam to come into direct contact with electrical components.
- If high-pressure water is sprayed directly onto electrical fittings, hydraulic fittings, hydraulic pistons, and hydraulic manifolds may cause failure. When cleaning, do not allow the high-pressure water to get into these components directly. Wipe off any dirt with soft cloth.

Precautions for Inside the Cab

- Do not leave tools or machine parts lying around inside the operator’s cab. If tools or parts get into the control devices, it may obstruct operation and cause the machine to move unexpectedly, resulting in serious personal injury or death.
- Do not use a cellular phone when operating the machine. This may lead to mistakes in operation and may cause serious personal injury or death.
- Never bring any dangerous objects such as flammable or explosive items into the operator’s cab.

Use Handrails and Step when Getting On or Off Machine.

To prevent personal injury caused by slipping or falling off the machine, always observe the following:

- Always face the machine and maintain at least three-point contact (both feet and one hand or both hands and one foot) with the handrails and steps to ensure that you support yourself.
- Before getting on and off the machine, check the handrails and steps if there is any oil, grease, or mud on them. Wipe it off immediately so as not to slip. In addition, tighten any loose bolts on the handrails and steps. If the handrails and steps are damaged or deformed, they need to be repaired immediately.
- Do not grip the control levers or lock lever when getting on or off the machine.
- Never climb on the engine hood or covers where there are no non-slip pads.
- Never Jump off of the Machine – unless necessary to as an avoidance of electrical shock.



Precautions to Prevent Fire

- Do not bring any open flame close to flammable substances such as fuel, oil, coolant, or window washer fluid. There is a danger that they may catch fire.
- Do not smoke or use an open flame near fuel or other flammable substances.
- Shut down the engine before adding fuel.
- Do not leave the machine when adding fuel or oil.
- Tighten all the fuel and oil caps securely.
- Be careful not to spill fuel on overheated surfaces or on parts of the electrical system.
- After adding fuel or oil, wipe up any spilled fuel or oil.
- Put greasy rags and other combustible materials into a safe container to maintain safety at the workplace.
- When washing parts with oil, use non-flammable oil. Do not use diesel fuel or gasoline. There is a danger that they may catch fire.
- Do not weld or use a cutting torch to cut any pipes or tubes that contain combustible liquids.
- Determine well-ventilated areas for storing oil and fuel. Keep the oil and fuel in the specified place and do not allow unauthorized person to enter.
- When performing grinding or welding work on the machine, move any flammable materials to a safe place before starting.
- Remove any dry leaves, chips, pieces of paper, dust, or any other combustible materials accumulated or affixed around the engine exhaust manifold, muffler, battery, or cowling.
- To prevent fires from spreading sparks or burning particles from other fires, remove any combustible materials such as dry leaves, chips, pieces of paper, or any other combustible materials accumulated around the cooling system (radiator, oil cooler) or inside the undercover.
- Short circuits in the electrical system can cause fires. Check to see that all power cables and wirings are in good condition. Keep all electrical connections clean. Bare wire or frayed insulation can cause a dangerous electrical shock and personal injury.

- Keep all the electric wiring connections clean and securely tightened.
- Check the wiring every day for looseness or damage. Reconnect any loose connectors or refasten wiring clamps. Repair or replace any damaged wiring.
- Check that all the hose and tube clamps, guards, and cushions are securely fixed in position. If they are loose, they may vibrate during operation and rub against other parts. There is danger that this may lead to damage to the hoses and cause high-pressure oil to spurt out, leading to fire and serious personal injury.

Precautions regarding highly heated exhaust gas

- The machine is equipped with Diesel Particulate Filter (hereafter DPF). DPF is a device to purify the soot in the exhaust gas. Exhaust gas temperature may increase during the filter cleaning/purification process (regeneration / ReGen). Do not bring any combustible material close to the outlet of the exhaust pipe. Be aware of nearby combustible materials that may be inadvertently heated by exhaust gases.
- When there is brush, trees, dry leaves or other combustible matter near the job site, be aware that the DPF regeneration may present a fire hazard. The system can be set to disable DPF ReGen if necessary.

Precautions regarding sensitive electrical components and welding

- The machine is equipped multiple electronic controllers and electronically actuated hydraulics. Electrical surges to the machine can damage the sensitive electronic controls.
- Do not weld on the unit.
- Electrical components damaged by welding are not covered under warranty.



Precautions regarding corrosion

Regularly inspect the unit for corrosion. To help prevent rust on the unit, it is important to regularly apply a corrosion inhibitor / lubricant like TC-11™ Corrosion Inhibitor or equivalent to exposed metal as well as fairlead rollers and pins. If the unit is stored outdoors, a corrosion inhibiting product should be reapplied every 6 months. The product should also be reapplied if a visual inspection indicates that surface areas are no longer glossy. The friction between the ropes and the surface of the reel and rollers can accelerate the degradation of any corrosion inhibiting coating, therefore, the reel and rollers should be examined after each use to determine if reapplication would be beneficial.

Precautions regarding rope, rope eyes, grips, and swivels.

All mechanical components are subject to wear. Worn components do not have the same *Maximum Load Limit* rating as do new components. The total responsibility for the inspection, maintenance, lubrication, and continued use is entirely up to the purchaser/user. Remember, visual inspection may not be sufficient and examination methods such as X-ray, ultrasonic testing, magnetic particle inspection, dielectric resistance and others, might be required to establish the present integrity of the product. External factors will affect the longevity of the product. There is no defined time period for the useful life of any of these products.

Check to see that your equipment is being inspected and tested in accordance with all applicable governmental rules and regulations and Original Equipment Manufacturer (OEM) guidance. Should any products become worn and in need of repair, the responsibility for the actual repair work will be borne solely by the party making such repairs. It is recommended that the OEM be contacted should there be any questions whatsoever relating to a repair.

Contact information for the Original Equipment Manufacturers (OEM) for the peripheral equipment: grips, swivels, wire, and rope - provided with Sherman+Reilly™ equipment is provided at the back of this manual. This contact information is provided as a courtesy by Sherman+Reilly in an effort to keep end users well informed of the maintenance and safety requirements for this equipment. For the latest information on any of this accessory equipment check with the Original Equipment Manufacturer.

2.4.6 Pre-Towing Checklist

- _____ 1. Make certain tow vehicle has the capacity and rating to tow machine safely.
- _____ 2. Inspect pintle eye for excessive wear, corrosion, cracked welds or structural damage. Check the bolts holding the pintle eye in place.
- _____ 3. Inspect tow vehicle hitch and ensure hitch.
- _____ 4. Make sure trailer brakes are operable.
- _____ 5. Make sure the unit is safe for towing with tires in good condition and properly inflated.
- _____ 6. Make sure there are no tools, objects, or trash items which could fall off during transport.
- _____ 7. Chock wheels on both sides of the machine/unit trailer, then start machine/unit engine- (*See Operator Controls and Start-Up Procedure*).
- _____ 8. Make sure the right and left bumper jacks are fully retracted- (*See Jack Controls*).
- _____ 9. Open the tow vehicle hitch and back vehicle into position. Set tow vehicle parking brake.
- _____ 10. Slowly retract trailer tongue jack, so that the pintle eye rests correctly in hitch strike plate.
- _____ 11. Ensure the hitch is secured. Connect the safety chains. The safety chains should be crossed and short enough to prevent the tongue from digging into the ground, should the unit unintentionally become disconnected. The chains should be no longer than necessary to allow slack for turning – crossing the chains provides directional control.
- _____ 12. After the trailer is secured to the vehicle, stop the machine/unit engine, and remove the key from the ignition key switch.
- _____ 13. Connect the electrical plug to the tow vehicle and check:
 - Clearance lights
 - Brake Lights
 - Turn Signals
 - Brakes
- _____ 14. Remove and store the wheel chocks.

2.4.7 In the Event a Fire Occurs

Most Sherman + Reilly™ equipment comes standard with a fire extinguisher mounted somewhere on the equipment for quick access by the operator. However, should a fire occur with S+R equipment; the **operator should only utilize the provided fire extinguisher, if trained in its use, if safe to do so, if in accordance with employer policy, and in these described situations:**

- a. To save your own life, if in jeopardy from fire.
- b. To save someone else's life, if in jeopardy as a result of a fire- but only if safe to do so.
- c. To put out small equipment fires to avoid further damage to equipment or prevent a dangerous explosion, but only if safe to do so.
 - Turn the starting switch to OFF position, and stop the engine.
 - Use the handrails and steps to escape from the machine.
 - Do not jump off the machine; there is the danger of falling, which could cause serious personal injury.
 - The fume generated by a fire contains harmful materials which have a bad influence on your body when they are inhaled.
 - Do not breathe the fumes.

CAUTION: Operators should exercise caution when attempting to put out fires, as **the provided extinguisher is only intended to suppress small localized fires**, and is not intended to put out or “fight” large scale fires, should one occur.

With the presence of flammable fluids and other operational environment factors, even small fires can grow out of control quickly- operators must maintain awareness of these factors.

Proper training must also be provided by employer before engaging in any firefighting efforts. Should a fire occur with Sherman + Reilly™ equipment, the operator should **not** use the equipment until it has been inspected for safety and approved to be returned to service- regardless of the size of the fire.

Emergency Stop Procedure

In the event of an emergency, the operator must be aware of how to shut down the machine so as to avoid any additional injuries or equipment damage. In these emergency situations, the lives of lineman, work crews, surrounding bystanders, as well as the operator may become at risk- dependent upon the severity of the situation. As an operator in these situations, the level of operating knowledge and proficiency can be tested. These factors alone make this procedure one of the most important to know.

1. The first step of an emergency shut down during operations is to de-energize the drive system/engine and stop all equipment rotation and power as quickly as possible. This is done by **pushing one of the installed Emergency Stop Buttons** located on sides of the machine or on the control panel. Know the location of these E-stop switches.
2. If the Emergency Stop Button is pushed during operations and other machines/operators are being utilized in tandem or sync with your machine, notify them as quickly as possible that an emergency has occurred and advise to halt rotations.
3. Quickly assess situation and assist any injured personnel to get free from hazards- only if safe to do so.
4. Notify proper authorities and get help.
5. Follow all employer emergency procedures.



2.4.8 Unauthorized Modifications

- Sherman + Reilly™ will not be responsible for any personal injuries, product failures, physical loss or damage, or impacts to the environment resulting from modifications made without written authorization from Sherman + Reilly™.
- Any modifications made without written authorization from Sherman + Reilly™ can create hazards. Before making any modifications, consult Sherman + Reilly™.
- Any modifications made without authorization from Sherman + Reilly™ will void any written or implied warranty.

2.4.9 Precautions When Running Engine Inside Building

- The engine exhaust gas contains substances that may damage your health and even cause death. Start or operate the engine in a place where there is good ventilation. If the engine or machine must be operated inside a building or underground, where the ventilation is poor, take steps to ensure that the engine exhaust gas is removed and that ample fresh air is brought in.

2.4.10 Investigate and Confirm Jobsite Conditions

- On the jobsite, there can be various hidden dangers that may lead to serious personal injury or death. Before starting operations, always check the following to confirm that there is no danger on the jobsite:
- Always be careful when performing operations near materials such as shingled roofs, dry timber, dry leaves, or dry grass because they are easily combustible and may cause fire.
- Check the terrain and condition of the ground at the jobsite, and determine the safest method of operation. Do not operate in a dangerous area where landslides or falling rock may occur.
- If water lines, gas lines, or high-voltage electrical lines may be buried under the jobsite, contact the appropriate authority to identify their locations, and take care not to damage any of these lines.
- In particular, if you need to operate on a road, protect pedestrian and cars by designating a person for jobsite traffic duty or by installing fences around the jobsite.

2.4.11 Precautions When Working on Loose Ground

- Avoid operating the machine near the edge of cliffs, bluffs, road edges, and deep ditches. The ground may be weak in such areas. If the ground should collapse under the weight or vibration of the machine, there is a hazard that the machine may fall or tip over. Remember that the soil is weak in these areas, especially after heavy rain, blasting, or earthquakes.
- When working on embankments or near excavated ditches, there is a hazard that the weight and vibration of the machine will cause the soil to collapse. Before starting operations, take steps to ensure that the ground is safe and to prevent the machine from rolling over or falling.

2.4.12 Positioning the Machine

WARNING: DO NOT OVERSTRESS THE HITCH AND TRAILER TONGUE. The trailer frame is not designed to support the weight of the pulling vehicle. If the unit is to remain connected to the towing vehicle, extreme caution should be taken to assure that the pintle-eye hitch does not lift the towing vehicle in conjunction with leveling and lifting with the trailer's hydraulic jacks. Overloading the pintle-eye hitch connection and trailer tongue can cause structural damage to the trailer frame.

The driver/operator should position the puller in a suitable location where it will be free from obstructions and clear of any apparent hazards. For overhead pulling, the puller should be approximately three times (3X) the distance of the lead block height.

Example: If the lead block is 40 feet high, it is recommended that the puller be positioned approximately 120 feet from the base of the pole whenever possible. By allowing the distance to the lead block as specified, this reduces the direct downward forces that would be created otherwise. In some situations, however, it may not be possible to achieve these distances. (*see note below*).

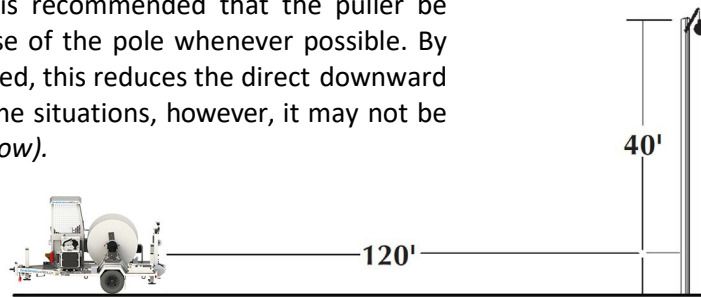

NOTE: In some situations, (i.e., due to rough terrain), it may not be possible to achieve safe distances from the lead block. In such situations, operators should establish as much distance as possible from the lead block and remain aware of the increased down forces during operations.

The unit should be leveled as much as possible, centered on the lead block, and parallel to the line being pulled prior to beginning operations.

CAUTION: All jacks should be extended for stabilization, and the machine must be leveled prior to conduction operations.

The operator must chock the trailer wheels prior to operations and any time the vehicle is parked. All appropriate grounding, anchoring, and protective equipment must be installed and secured to machine prior to operations.

3 Controls

3.1 General Overview

Sherman + Reilly™ Revolution Series PT-3000 Single Drum Puller/Tensioner is a multi-purpose puller and tensioner capable of pulling up to 3000 lb overhead with underground pulling capabilities up to 7500 lb, and a Spider™ Pilot Line system with an integrated levelwind.

This distribution class puller utilizes operator managed horizontal levelwind that permits overhead rope retrieval with precision control. The PT-3000 is equipped with an ACG (advanced control group), allowing for a single operator at a protected central console to control payout speed, pulling speed and tension, and levelwind controls. The operator controls employ electronic machine control with CAN-bus technology, providing for accurate to-the-second display readouts of the machine system status.

The operator controlled hydraulically actuated levelwind helps ensure even distribution of rope during pulling operations, thereby minimizing the risk of tangles and overlap, and maximizing rope life. The levelwind design also has a standby positioning during payout and tensioning operations.

The PT-3000 is equipped with either a turbo-charged industrial Tier 4 Final diesel engine that delivers 49 HP at 2700 RPM and 3,000 lb of line pull, at the top of the drum, or alternatively a gasoline engine that delivers 38 HP at 3200 RPM.

The hydraulic direct-drive system provides the operator with precise and intuitive automatic drive/drum braking. The PT-3000's single-axle trailer is equipped with three hydraulic jacks, an adjustable pintle eye, safety chains/hooks, leaf-spring axle suspension, and U.S. DOT-approved LED lighting.

The cab includes a fully adjustable ergonomic seat, and all required electronic controls and gauges. An optional LED work light provides extra light for those jobs that start early or end late.

Optionally, the PT-3000 can also be fitted with a Pad Mounted Transformer Adapter (PMTA), which coupled with the Underground (UG) drum, further transforms the unit to a solid multi-tasking puller/tensioner capable of routine underground pulls.

Key Features

- Hydraulic/Direct Drive System that can be easily uncoupled
- 66-inch Drum; 38-inch width
- Underground pulling capability up to 7500 lb with underground drum
- Walk-off Payout functionality
- 49 HP Tier4F Kubota Diesel Engine
- Levelwind
- Hydraulic Jacks
- 10.4 cu. ft. Frame Mounted Tool Box
- Centralized Engine Controls- CANbus technology

3.2 Specifications

Specifications Details: PT-3000

(Dimensions, weights, and capacities listed are approximate. All specifications are subject to change without notice.)

Pulling Capacity	3,000 lb	
Tensioning Capacity	2,000 lb	
Average Line Speed	Pulling: 4 mph / Payout: 10 mph	
Maximum Conductor Reel Size	66 in. Diameter (≤39 in. wide) / 38 in. Width / 6,000 lb Weight	
	Core Diameter:	18 in.
	Total Width:	38 in.
	Flange Diameter:	46 in.
Drum Capacity	11 mm. dia. Unitrex™	21,000 ft.
	5/8 in. dia. Uniline™	10,500 ft.
Drive System	Direct Drive: single hydraulic motor, drum/reel shaft coupler and drive bar/dual pin	
Drive System Engine	Vertical 4-cycle, liquid cooled, turbo-charged, direct drive 49 HP T4	
Fuel Capacity	13 gallon	
Hydraulic Fluid	ISO Grade 32	
Hydraulic Reservoir	25 gallon (20 usable gallons)	
Fail Safe Brake	Spring applied, hydraulic pressure released.	
Levelwind	Hydraulically driven, electronically operator controlled	
Operator's Safety Enclosure	Open cab, partially enclosed/3 sided	
Frame Construction	Steel tubing, steel plate, continuous weld	
Length (Overall, Nom.)	16 ft., 9 in.	
Width (Overall, Nom.)	8 ft., 5 in.	
Height (Overall, Nom.)	9 ft., 5 in.	
Weight (With Rope)	8,700 lb. (included 46-inch drum with 5/8 inch x 6000 ft. Uniline® rope)	
GVWR	10,000 lb.	
Suspension	Leaf spring	
Axle Configuration	Single	
Wheel Configuration and Tires	Dual, 235/85 R16	
Brakes (Trailer)	Electric, with break-away switch	
Towing Attachment	3 in. adjustable pintle eye, with two safety chains and hooks	
Tie Downs (4)	5/8 in. dia. steel D-Rings	
Tie Off Point	Tie-off point at rear bumper: 3500 lb. at 45°	
Grounding	Four ¾ in. diameter copper-clad steel loops	
Rear (R/L) Jacks (2)	Hydraulic, with shoe	
Front/Nose Jack (Rear)	Hydraulic, with shoe	
Electrical System	12 VDC	
Battery (1)	12 V, 810 CCA, BCI, group 27	
Lights / Navigation	12 V, LED, U.S. DOT-approved	
Grounding (4)	¾ in. dia. copper-clad steel loops	
Wheel Chocks	Standard	
Fire Extinguisher	ABC	
Color	S+R White	
Options		
Overhead Drum	Core: 18 in., Width 30 in., Flange 46 in.	
Underground Drum	Core: 12.75 in., Width 31.75 in., Flange 24 in.	
Spider – Pilot Line System	S-75: Core: 20 in., Width 9.25 in., Flange 27.25 in.	
	S-85: Core: 20 in., Width 14.5 in., Flange 30 in.	
Pad Mounted Transformer Adapter		
RCR-60 Reconductoring Reel		

3.3 Terms to Know

- | | | |
|-------------------------|---------------------------------|----------------------|
| 1. Cab | 11. Exterior Hydraulic Controls | 21. Engine |
| 2. System Control Panel | 12. PMTA Boom Mount | 22. Fuel Tank |
| 3. Operator's Chair | 13. Steps | 23. Hydraulic Filter |
| 4. Control Box | 14. Tie-downs | 24. Reel Motor |
| 5. Emergency Stop | 15. Fire Extinguisher | 25. Battery |
| 6. Freewheel Brake | 16. Tongue (front) Jack | |
| 7. Spider Reel Drive | 17. Grounding Loops (4) | |
| 8. Bumper (Rear) Jacks | 18. Pintle Eye | |
| 9. Reel Levelwind | 19. Wheel Chocks | |
| 10. Spider Levelwind | 20. Hydraulic Tank | |

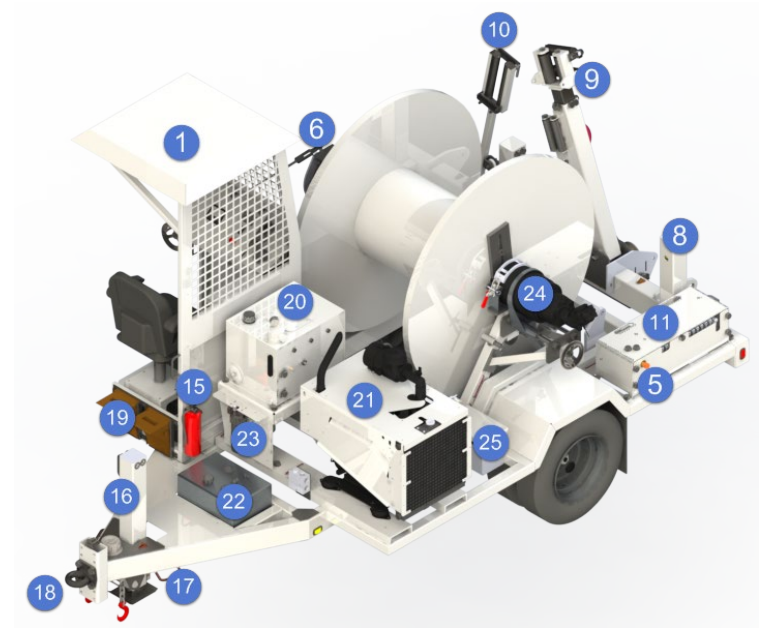
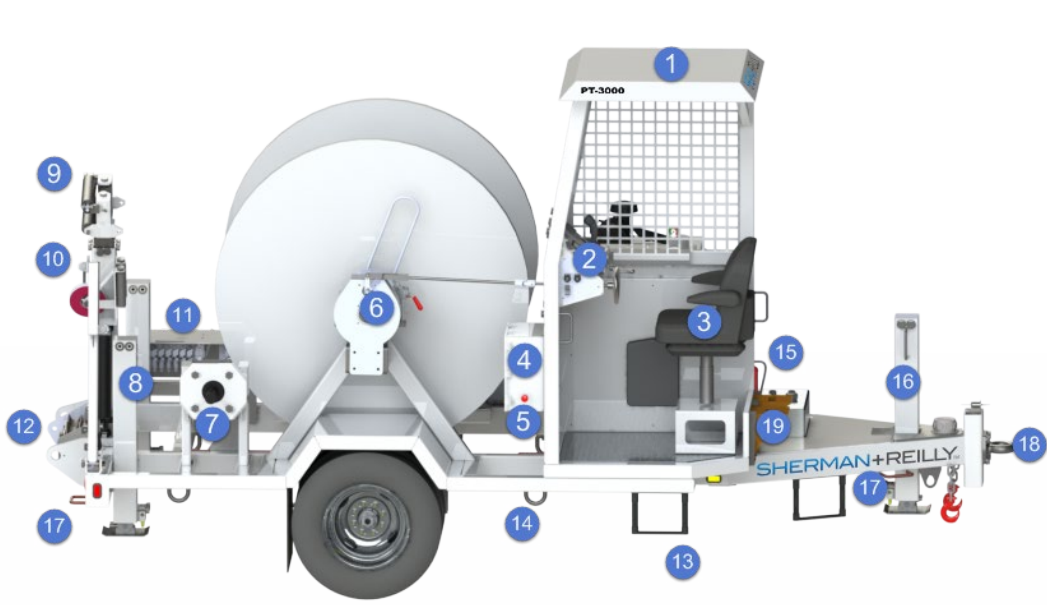

3.4 Operator Controls

3.4.1 Control Panel on the Unit



- ① Control Screen
- ② Control Switches
- ③ Key Switch
- ④ Payout Brake Control
- ⑤ 12 v DC outlet
- ⑥ USB Accessory Charger
- ⑦ Joystick Control
- ⑧ Emergency Stop

NOTE: Product images shown are for illustration purposes only and may not be an exact representation of your product. Actual product may vary due to continual product enhancement and improvement.

Master Power Key Switch

This switch is used to control power to the operator controls and engine.

CAUTION: Always ensure that the master power key switch is turned to the [OFF] position when the machine is not in use. If the machine is to be left unattended, remove key from the key switch and stow in a secure place, while also securing the operators cab to prevent any unauthorized access to the controls or operation of the machine.

CAUTION: Before starting the machine or engaging any machine component, read and observe all safety precautions and operational procedures listed in this manual.

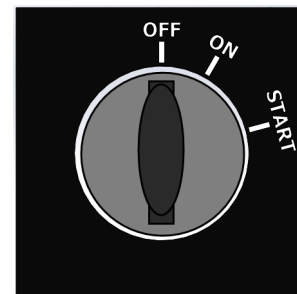

Emergency Stop Button

When pushed, this red push button stops all operation functions, turning off system and engine power, while disengaging all controls. After being depressed, the button must be rotated and released to the disengaged position to restore power to the system and re-engage operator controls.

NOTE: The emergency stop button should only be used to stop the machine in an emergency situation where there poses a risk of injury or death to personnel or to prevent equipment or property damage. When this button is pushed, line tensions can change rapidly. For more information on emergency shut down situations- (see *the Emergency Stop Procedure*).



4 Handling and Operation

4.1 Pre-Operation Inspection

Perform the following checks before starting the engine. At the beginning of the day's work to ensure that there is no problem with the operation of the machine. If these checks are not performed properly, problems may occur with the operation of the machine, and there is a danger which may lead to serious personal injury or death.

1. **Check the engine radiator coolant level**, by opening the radiator cap. CAUTION: Ensure radiator cap is reinstalled and tightened prior to operations.
2. **Check for proper engine oil level**. After checking oil level, wipe dipstick clean of any debris prior to reinserting into spout.
3. **Check hydraulic fluid reservoir level**, by viewing the sight gauge on the side of the tank.
4. **Check inside engine compartment for debris**. Open all engine compartments, while inspecting compartment latches. NOTE: Be sure the engine covers are replaced and latched in position properly before transport or operating the machine.
5. **Inspect drum and/or bullwheel surfaces** for signs of damage or excessive wear.
6. **Inspect hydraulic systems** - pump, drive motors, and hoses for loose fittings, leaking fluid, and damaged hoses.
7. **Inspect the battery, terminals, and wires** for any signs of corrosion or damage.
8. **Close and re-secure all latches**, engine compartments, and panels.
9. **Inspect for damage**, bent or broken parts, cracked or broken welds, missing pins and retainers.
10. **Inspect all equipment grounds** for any signs of damage.
11. **Inspect all jacks** for damage or leaking hydraulic components.
12. **Inspect connected** reel stands, drive motors, drive bars, drive pins, and reel shaft couplings to ensure they are secure and that there are no obvious signs of damage- if damaged do not operate, service may be required.
13. **Inspect fairleads and rollers** for any obvious signs of damage, and ensure rollers move freely.
14. **Check fuel level and battery charge**- With key inserted in master power key switch, turn key to the ON position to activate the display. The fuel level will show on the engine information screen.
15. **Check surrounding area**
 - a. Check that there is no combustible material that could be ignited by high temperature exhaust during operations, especially during regeneration of a diesel particulate filter.
 - b. Check that the ground where the machine is located is stable.
 - c. Check that there are no persons in the area around the machine.
16. **Conduct towing readiness inspection**.
 - a. Inspect all trailer connections, and ensure that the hitch is secured, and air supply/electrical hoses and trailer lighting are connected.
 - b. Inspect tail lights to ensure all lights work- replace bulbs as needed. If none of the lights work, inspect vehicle fuses and trailer wiring for corrosion.

- c. Ensure that trailer brakes work and that wheel chocks are available.
- d. Check tire pressure- tire pressures are posted on the tire sidewall.
- e. If tire pressure slow, inspect tire for damage or punctures. If damaged or punctured, have repaired or replace.
- f. Ensure that all jacks are raised and that trailer is clean and free from trash or debris.

17. Inspect Fire Extinguisher.

- a. Inspect fire extinguisher charge, and ensure that gauge shows within charge limits.
- b. Inspect the physical condition of the extinguisher- (cylinder, hose/cone assembly, etc.), for any signs of damage or corrosion.
- c. Ensure that hinge pin is in place, to prevent accidental discharge.
- d. Ensure that the plastic safety seal is secured to hinge pin, and that it has not been removed.
- e. Inspect mounting strap/bracket assembly to ensure extinguisher is secured to structure.

CAUTION: Unless operating in an extreme heat environment, ensure all engine compartment panels are re-secured and latched in position properly before operating or transporting the machine.

4.2 Start Up and Set Up Procedure

- 1) Perform all pre-operation inspections.
- 2) Position the machine in a suitable location for the pull. The machine should be positioned centered on the lead block, and parallel to the line being pulled prior to beginning operations. Wheels should be chocked to prevent the unit from rolling.
- 3) Ensure that all controls (levers, switches, etc.) are in the neutral and disengaged position (see Operator Controls section). Ensure Emergency Stop switches are in neutral position.
- 4) With the key inserted, turn master power key switch to the POWER ON / ENGINE START position; hold briefly (~ 2 seconds) and release.
- 5) The main control screen will flash the S+R logo, then the MAIN screen will be visible with all the potential error message indicators.
- 6) View the control panel [MSG] screen to ensure there are no warning or fault messages
- 7) Once the error messages clear, the MAIN screen is visible, turn the Master Power Key switch to [START]; hold briefly (~ 1 second) and release to start the engine. The unit will beep twice and the engine will start. If the engine does not start, check [MSG] to see if there are any error messages.
- 8) WARM-UP HYDRAULIC FLUID. For safe operations, it is recommended that the hydraulic fluid be allowed to warm-up to a working temperature prior to use of any hydraulic functions. Cold hydraulic fluid can damage the machine.
- 9) Level and stabilize the machine using the available hydraulic jacks- (see Jack Controls section).
- 10) Properly ground and anchor the machine to prevent the machine from moving under tension or line load.

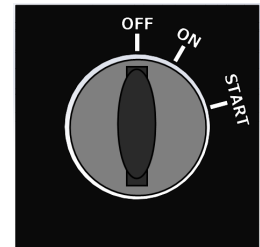

CAUTION: All jacks must be extended for stabilization, and the machine must be leveled, anchored, and properly grounded prior to conduction operations.

4.3 System Control Screen Descriptions

4.3.1 Main Screen

The Main Screen visible on the System Control Panel when the machine is first turned on shows the main system parameters that are of interest to an operator: current operating mode, fuel level, line tension, line speed, engine load, and distance.

If there is an Error, the backgrounds of the value fields will turn RED. This indicates that there is an error with an input sensor used to calculate that respective value. See MESSAGES screen to determine cause of error.

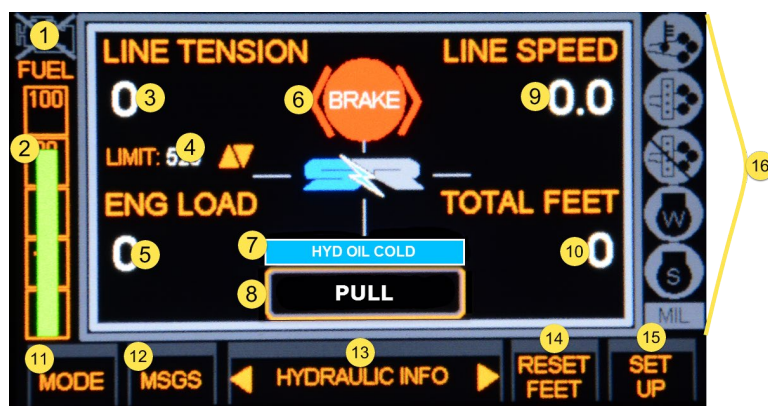

This screen also shows if the brake is engaged, DPF indicators, and if there are engine code.

1	ECU Communications indicator	Gray = GOOD / Red = ERROR. See sections on Error Messages and DPF Engine Indicators
2	Fuel Gauge (%)	Bar will flash RED to indicate low level (<= 15%).
3	Calculated Line Tension (LB)	
4	Tension Limit (LB)	Use Up / Down cursor soft-keys to adjust setting in 100 lb increments. [Range: 0-3500]
5	Engine Percent Load at Current Speed (%)	Received from ECU. Ratio of actual engine percent torque to maximum indicated torque available at current engine speed.
6	Reel Brake indicator	See MULTI-SCREEN ITEMS, POP-UP INDICATORS section for details
7	Hydraulic Oil Cold indicator	Visible when hydraulic oil temperature < 60°F.
8	Operating Mode indicator	Shows machine's current mode of operation: PULL, TENSION, PMTA, SPIDER, UG (Underground), PMTA BOOM. Will also display CommERROR if there is a communications error between Cr0452 display and Cr0233 controller.
9	Calculated Line Speed (MPH)	
10	Calculated Total Feet	Total length of line payed out, or pulled in. Counts UP (adds to current value) when Reel turns in Pay Out direction. Counts DOWN (subtracts from current value) when Reel turns in Pull-In direction. Zero by holding RESET FEET soft-key (item 20) for ~ 3 seconds.
11	MODE Selection soft-key	Hold key for ~ 0.5 seconds to change current operating mode. Mode can only be changed while Reel brake is applied / ON and joystick is centered.
12	MSGS soft-key	Push to go to MESSAGES screen. See MESSAGES SCREEN section for screen details. ORANGE frame indicates new indicator active on MESSAGES screen since last time screen was accessed.
13	Screen Selection Window	Use Left / Right cursor soft-keys to toggle through possible screens: ENGINE INFO, ENGINE ERRORS, HYDRAULIC INFO. Press OK soft-key to go to displayed screen.
14	RESET FEET soft-key	Push to zero TOTAL FEET field. Will not work if there are any errors related to ultrasonic sensor used to measure reel diameter.
15	SET UP soft-key	Push to go to SET UP screen. See SET UP SCREEN section for screen details.
16	Engine Indicators	See section on Engine Indicators.

4.3.2 Engine Information Screen

Screen is accessed by using **Screen Selection Window** on MAIN screen. Press ESC soft-key to return to MAIN screen. All values on this screen are received from ECU. Backgrounds of value fields will turn RED to indicate flawed value due to ECU communications error.

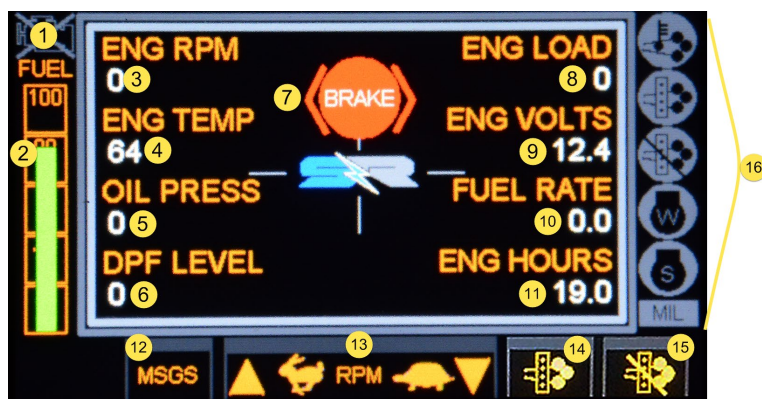

1	ECU Communications indicator	Gray = GOOD / Red = ERROR. See sections on Error Messages and DPF Engine Indicators
2	Fuel Gauge (%)	Bar will flash RED to indicate low level (<= 15%).
3	Engine RPMs	
4	Engine Coolant Temperature °F	Engine will shut down if the coolant temperature exceeds 240° Fahrenheit.
5	Engine Oil Pressure (PSI)	For diesel, T4F engines, monitored with a pressure switch. Engine will be stopped if < 29 psi. For gas engines, monitored with a sensor. Engine will be stopped if < 7 psi.
6	Current DPF Level (0-5) [for diesel, T4F engines only]	Level 0: REGEN is unnecessary. Level 1-2: REGEN can occur automatically. Level 3: PARKED, MANUAL REGEN is required Level 4-5: Non-warranty factory assistance from Kubota is required. IMPORTANT: Perform a Parked, Manual REGEN BEFORE engine reaches Level 4..
	Intake Air Temperature (°F) [for gas engines only]	Displays temperature or pre-combustion air found in intake manifold of engine air supply system. Engine will be stopped if > 180° Fahrenheit. INTAKE AIR TEMP 0
7	Reel Brake indicator	See MULTI-SCREEN ITEMS, POP-UP INDICATORS section for details.
8	Engine Percent Load at Current Speed (%)	Ratio of actual engine percent torque to maximum indicated torque available at current engine speed.
9	Battery Voltage (Volts)	Received from ECU. Background will turn RED to indicate flawed value due to ECU communications error.
10	Engine Fuel Rate (GPH)	Amount of fuel consumed by engine.
11	Engine Total Hours of Operation (HRS).	
12	MSGs soft-key	Push to go to MESSAGES screen. See MESSAGES SCREEN section for screen details. ORANGE frame indicates new indicator active on MESSAGES screen since last time screen was accessed.
13	Increase RPM soft-key Decrease RPM soft-key	Tap” Up cursor soft-key to increase engine RPM in increments of 100. Hold Up cursor soft-key for ~ 1 second to go to full RPMs. “Tap” Down cursor soft-key to decrease engine RPM in increments of 100. Hold Down cursor soft-key for ~ 1 second to go to idle RPMs.
14	REGEN Request soft-key [for diesel, T4F engines only]	Push for half (0.5) a second to request REGEN. This switch can only be used, and will only be visible, if the engine is running, REGEN conditions are met and a REGEN cycle is not taking place.
15	REGEN Inhibit Request soft-key [for diesel, T4F engines only]	Push for half (0.5) a second to request inhibiting REGEN. This switch can only be used, and will only be visible, if the engine is running and REGEN is <i>not</i> already happening. If the ECU accepts the request, the REGEN Inhibit indicator (item 14) will turn yellow.
16	Engine Indicators	See section on Engine Indicators.

4.3.3 Engine Indicators



CAUTION: HIGH EXHAUST TEMPERATURE

Active ReGen - Hot Exhaust warning. Be sure that exhaust will not come into contact with any combustible materials.



DPF Auto ReGen Active



DPF Regen Inhibited



Engine Warning Icon



Engine Stop Icon



Engine Malfunction Indicator

4.3.4 Hydraulic Information Screen

Screen is accessed by using **Screen Selection Window** on MAIN screen. Displays system and reel related information. Press ESC soft-key to return to MAIN screen. Backgrounds of value fields will turn RED to indicate error with any input sensor used to calculate value. See MESSAGES screen to determine cause of error.

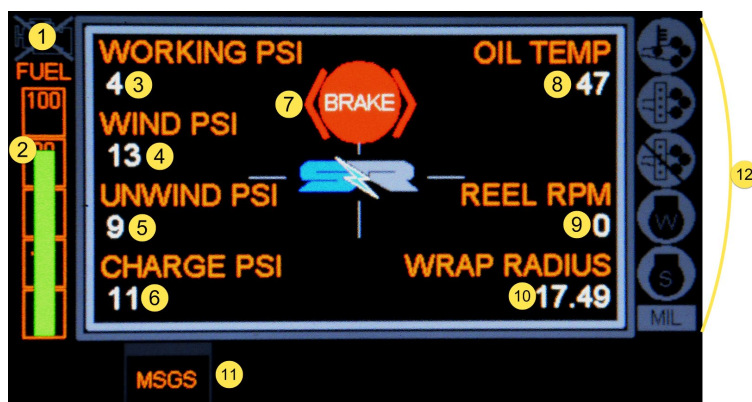

1	ECU Communications indicator	Gray = GOOD / Red = ERROR. See sections on Error Messages and DPF Engine Indicators
2	Fuel Gauge (%)	Bar will flash RED to indicate low level (<= 15%).
3	Working Pressure (PSI)	Difference between WIND and UNWIND pressures.
4	Wind Pressure (PSI)	I05 PULL IN pressure transducer scaled value (0-5000 psi).
5	Unwind Pressure (PSI)	I06 PAY OUT pressure transducer scaled value (0-5000 psi).
6	Charge Pressure (PSI)	I07 CHARGE pressure transducer scaled value (0-5000 psi).
7	Reel Brake indicator	See MULTI-SCREEN ITEMS, POP-UP INDICATORS section for details
8	Hydraulic Oil Temperature °F	I13 HYDTEMP temperature sensor scaled value
9	Calculated Reel RPM	
10	Calculated Wrap Radius - Inches	Based on I03 REEL DIA ultrasonic sensor feedback. Value is center of reel shaft to outer diameter of line wrap on reel
11	Soft Key to see Messages	
12	Engine Indicators	See section on Engine Indicators.

4.3.5 Set Up Screen – Security Level 0

Screen is accessed by pressing SET UP soft-key on MAIN screen. Press ESC Soft-key to return to MAIN screen.

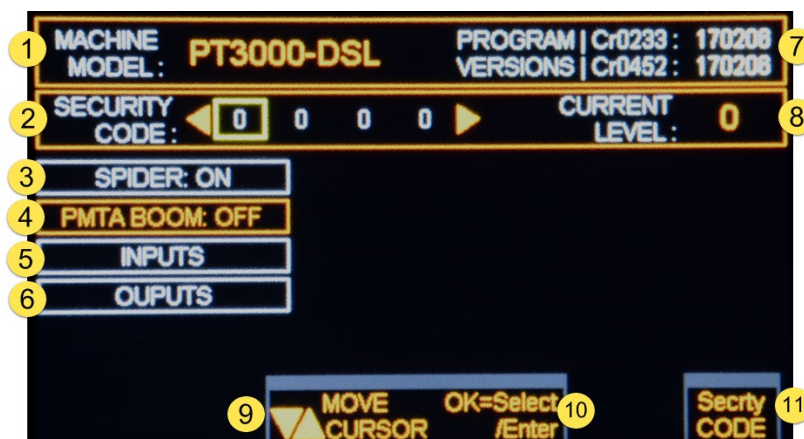

1	Machine Model indicator	Shows selected engine type: DSL = diesel, T4F, engine (default) GAS = gas engine
2	Security Code	Use Left / Right cursor soft-keys to move highlight box, when box is NOT flashing, to desired field. Press Security CODE soft-key (item 11) and use Left / Right cursor soft-keys to adjust selected field's value while highlight box is flashing. Press Security CODE soft-key when finished adjusting value. Code can only be entered when Current Level (item 08) = 0. Returning to MAIN screen automatically resets Current Level to 0.
3	Spider ON/OFF toggle	Press OK soft-key (item 10) while field is selected (ORANGE) to toggle state. PMTA BOOM toggle (item 4) must be OFF. Use Up / Down cursor soft-keys (item 09) to move selection cursor. ON = machine joystick controls spider reel related functions.
4	PMTA BOOM ON/OFF toggle	Press OK soft-key (item 10) while field is selected (ORANGE) to toggle state. SPIDER toggle (item 3) must be OFF. Use Up / Down cursor soft-keys (item 09) to move selection cursor. ON = machine joystick controls PMTA boom related functions.
5	Inputs	Press OK soft-key (item 10) while field is selected (ORANGE) to go to INPUTS screen. Use Up / Down cursor soft-keys (item 09) to move selection cursor.
6	Outputs	Press OK soft-key (item 10) while field is selected (ORANGE) to go to OUTPUTSscreen. Use Up / Down cursor soft-keys (item 09) to move selection cursor.
7	Program Versions	Current software versions of Cr0233 controller and Cr0452display.
8	Current Security Level (0-3)	Indicates the level of access permission.
9	Move Cursor	Use Up / Down cursor soft-keys to move between items03-06.
10	Select / Enter	Press OK soft-key to select/enter currently selected (ORANGE) field (items03-06).
11	Security Code Select / Enter	Press soft-key to edit currently selected security code field (item02). Press while security code highlight box is flashing to end editing.

4.3.6 Automatic Control System Shutdown

The system is programmed with an automatic shutdown feature. If the System Control is powered up but the engine has been off for 30 minutes, the System Control will power off after 5 minutes, if the engine is not started. This helps protect from draining the battery. The screen will display time before automatic shut-down

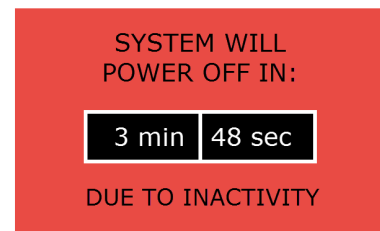

4.3.7 Controller Communications Error Screen

Screen appears if there is a communications error between Cr0233 controller and Cr0452 display. Hold OK soft-key ~ 3 seconds to “sleep” error message for 1 minute. Display will switch to MAIN screen. If error still exists, screen will reappear.



4.3.8 Error Messages

Message Screens are accessed by pressing MSGS soft-key on MAIN screen. Provides IO related warning / fault indicators. All possible indicators are listed on this screen. GRAY = inactive and YELLOW =active. Press ESC soft-key to return to MAIN screen.

PwrErr: CONTROLLER SUPPLY	ALTERNATOR ERROR
PwrErr: OUTPUTS Q00-07	WATER IN FUEL
PwrErr: OUTPUTS Q08-15	ENG SAFETY RELAY SIGNAL
PwrErr: OUTPUTS Q00E-07E	I02: SWASH PLATE POWER
PwrErr: OUTPUTS Q08E-15E	I02: SWASH PLATE SIGNAL
PwrErr: OUTPUTS Q00E-23E	I03: ULTRASONIC SIGNAL LOST
ESTOP: CONSOLE	I03: ULTRASONIC OPEN
ESTOP: CURB	I03: ULTRASONIC out of RANGE
ESTOP: STREET	I05: PULL IN PRESSURE sensor
HYD OIL LEVEL LOW	I06: PAY OUT PRESSURE sensor
HYD OIL TEMP HIGH	I07: CHARGE PRESSURE sensor
JOYSTICK ERROR	
KEYPAD ERROR	

I08: HYD MOTOR SPEED sensor	Q03E: JACK RET SOL-STREET
I12: FUEL LEVEL SENSOR	Q04E: JACK EXT SOL-TONGUE
I13: HYD OIL TEMP SENSOR	Q05E: JACK RET SOL-TONGUE
Q08: REEL PRESSURE SOL	Q08E: REEL LVLWIND-STREET
Q09: REEL PAY OUT SOL	Q09E: REEL LVLWIND-CURB
Q10: REEL PULL IN SOL	Q10E: SPIDER LVLWIND-STREET
Q12: SPIDER PAY OUT SOL	Q11E: SPIDER LVLWIND-CURB
Q13: SPIDER PULL IN SOL	Q12E: PMTA UP
Q00E: JACK EXT SOL-CURB	Q13E: PMTA DOWN
Q01E: JACK RET SOL-CURB	Q14E: PMTA STREET
Q02E: JACK EXT SOL-STREET	Q15E: PMTA CURB

The following “pop-up” indicators can appear on multiple (MAIN, ENGINE INFORMATION, & HYDRAULIC INFORMATION) screens:



= Indicates that reel brake is ON / applied. Disappears when the brake is released.



This only appears during TENSION mode when line tension is above 1,500 lbs. for 3 seconds. Indicator can be acknowledged / made invisible by holding the ESC key down for approximately 1 second while on the MAIN screen.



This only appears during PULL, TENSION, or UG modes when line tension is above (greater than) the set Tension Limit (set on MAIN screen). In PULL mode, tension limit must be exceeded for TENSION LIMIT TIMER set point value; the default setting is 10 seconds. In UG mode there is no delay or “de-bounce” time. When Tension Limit is reached, reel is brought to a controlled stop and the brake is applied. Joystick must be centered to reset indicator and re-enable reeloperation.

4.3.9 Engine Error Codes

Screen is accessed by using **Screen Selection Window** on MAIN screen. Displays Active Engine Error codes (maximum of 10) being reported by ECU. Contact engine supplier for detailed information on SPN / FMI codes. Press ESC soft-key to return to MAIN screen.



Engine Warning Icon signifies an error code.



Engine Stop Icon signifies an error code.



Engine Malfunction Indicator signifies an error code.



4.3.10 DPF and Engine Indicators

DPF LEVEL	Inhibit Switch	Active ReGen (High Exhaust Temp) Lamp	ReGen Needed/Request Lamp	MIL Lamp
				MIL
LEVEL 1: Active ReGen				
ReGen Not Needed	ON	OFF	OFF	OFF N/A
ReGen Not Needed	OFF	OFF	OFF	OFF N/A
LEVEL 1: Active ReGen				
Active ReGen Needed	ON	OFF	SOLID LIGHTING	OFF N/A
Active ReGen Occurring	OFF	SOLID LIGHTING	SOLID LIGHTING	OFF N/A
LEVEL 2: Active or Parked ReGen				
Active ReGen Needed Parked ReGen Needed	ON	OFF	BLINKING LIGHT	OFF N/A
Active ReGen Occurring Parked ReGen Occurring	OFF	SOLID LIGHTING	SOLID LIGHTING	OFF N/A
LEVEL 3: De-rating Power & Speed				
Parked ReGen Needed	ON	OFF	BLINKING LIGHT	ON
Parked ReGen Occurring	OFF	SOLID LIGHTING	SOLID LIGHTING	ON
LEVEL 4: De-rating Power & Speed				
Parked ReGen Needed	ON	OFF	BLINKING LIGHT	ON
Parked ReGen Occurring	OFF	SOLID LIGHTING	SOLID LIGHTING	ON
LEVEL 5: ENGINE STOP				
DPF Service Required (Active & Parked ReGen Disabled)	ON	OFF	BLINKING LIGHT	ON
DPF Service Required (Active & Parked ReGen Disabled)	OFF	OFF	BLINKING LIGHT	ON

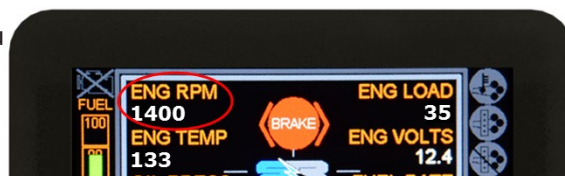

4.4 Engine Throttle Control

Engine throttle control is managed automatically by the control system depending upon the power demand. The RPM on the engine can also be increased or decreased from the System Control Panel Engine Information Screen in 100 RPM increments, depending upon the power demands of the pull, using the Up/Down arrows on the Control Panel,

4.1 Jack Controls

The engine must be running for the jacks to function. All the jacks can be operated from the switches in the cab or from the exterior hydraulic controls. The tongue (front) jack can also be operated via a switch located adjacent to it.

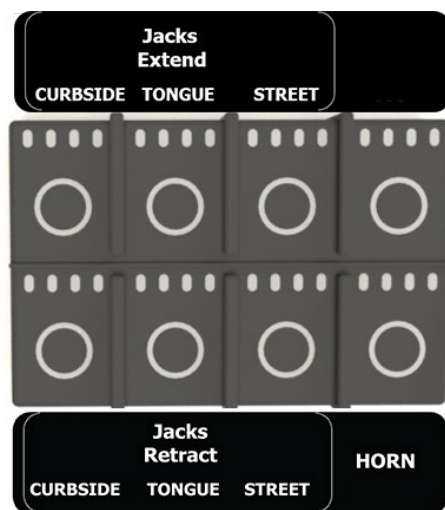

4.2 PMTA Boom Control

The optional PMTA Boom is controlled via the joystick when the unit is in PMTA Mode at the System Control Panel. See optional PMTA Instructions for additional information.

To utilize the PMTA Boom:

- 1) At the MAIN Screen at the System Control Panel, go to the SETUP Screen.
- 2) At the SETUP Screen, use the arrow keys to move the highlight box to PMTA BOOM ON. 
- 3) Push the OK button to turn the PMTA BOOM ON.
- 4) Press ESC to return to the MAIN Screen which will indicate that the unit is in the PMTA MODE.
- 5) The PMTA Boom can now be positioned using the Joystick.
 - To lower the boom, push the joystick forward.
 - To raise the boom, pull the joystick back.
 - To rotate left (CurbSide) push the joystick left.
 - To rotate right (StreetSide) push the joystick right.
- 6) After positioning the PMTA Boom in place, return to the SETUP Screen. Highlight PMTA BOOM: OFF and press OK.
- 7) Press ESC to return to the MAIN Screen.
- 8) Select UG mode on the system control display by pressing the MODE button. This setting is defaulted to whatever was last set for the system. If the system is already in UG mode, there is no need to change this setting.

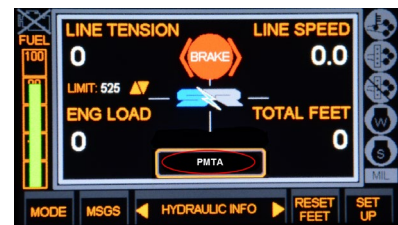

See the Underground Pulling section for operations.

4.3 Brake Operation

The drum brake status is shown in the center of the Main system control panel screen. This symbol indicates that reel brake is ON / applied. Disappears when the brake is released.



By default, the drum brake will be ON when the machine is started. To disengage the hydraulic drum brake, depress the joystick trigger then pull the joystick slightly backward and out of neutral. It may take a few seconds for the system to build up hydraulic pressure before the brake is released and the drum will begin to spin. Returning the joystick to center without the trigger depressed will activate the brake.

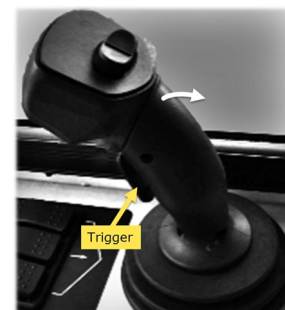

The set the drum brake, place the joystick control into the center neutral position with the trigger released, or double tap the trigger.

CAUTION: Once the hydraulic brake is released, the trigger must be held when pushing the joystick forward through center neutral to keep the brake from reapplying. The trigger is used to release the brake when the joystick is pulled back from center neutral and to keep the brake released when passing forward through center neutral. Once the joystick is forward of center neutral, the trigger should be released.

WARNING: To avoid potential personal injury and/or equipment damage, ensure that any vehicle actively pulling out line has completely stopped before returning the joystick to the center neutral position and setting the brake. Limit pull off vehicle speed to account for sudden accidental changes in line tension.

If the joystick is placed in or passes through center/neutral with the trigger released, the hydraulic drum brake will set halting operations.

WARNING: Once the hydraulic brake is released, the operator should release the joystick trigger. This ensures that if the brake is needed for a rapid halt and the operator returns the joystick to the neutral position, the trigger will not be inadvertently pressed preventing the brake from engaging.

CAUTION: Before handling any pilot, pulling, or conductor lines attached to this machine, the operator must ensure that the hydraulic drum brake is set and the joystick is in the neutral position with the trigger released.

CAUTION: Always ensure that the hydraulic drum brake is set before attempting to tie off any line or conductor that is tied to or being managed by this machine. The operator should never hold tension on the line using the drive system while the line is being tied off. Always set the brake first.

4.4 Hydraulic Manual Override

This exterior hydraulic control manifold, located on the rear street side, provides the operator with an emergency hydraulic override controls for the jacks, reel, and levelwind. The optional PMTA boom can also be operated from these controls, when installed. The engine must be running for the hydraulics to operate. A set of handles is provided in the toolbox in the event the manual overrides need to be used to operate the machine. See the decal on the machine for additional instruction.

B	SPIDER REWIND	SPIDER LEV WIND RETRACT	TONGUE JACK RETRACT	STREET JACK RETRACT	CURB JACK RETRACT	MAIN REEL LEV WIND RETRACT
A	SPIDER PAYOUT	SPIDER LEV WIND EXTEND	TONGUE JACK EXTEND	STREET JACK EXTEND	CURB JACK EXTEND	MAIN REEL LEV WIND EXTEND

4.5 Hydraulic Warm-Up

For safe operations, it is recommended that the hydraulic fluid be allowed to warm-up to a working temperature prior use pulling. Sherman + Reilly™ units ship with ISO 32 hydraulic fluid.

Cold hydraulic fluid can damage the machine. This blue temperature message on the System Control Panel indicates that the oil temperature is below 60° F (16° C). It will disappear once the hydraulic oil exceeds 60° F (16° C).



The current temperature of the hydraulic oil can be viewed on the Engine/Hydraulic Information Screen from the Setup menu screen.

4.6 Diesel Particulate Filter (DPF) Re-Generation Information

PT-3000 employs a T4 Diesel Engine that utilizes a Diesel Particulate Filter (DPF) to remove soot and undesired combustion gas from the exhaust system. This filter must be periodically cleaned. During normal operation, the regeneration (ReGen) of the DPF occurs automatically. However, under certain conditions (particularly when the engine is lightly loaded for long periods of time) or the unit was shut down before ReGen was completed, the operator may have to instruct the control system to perform a manual cleaning of the DPF system.

A DPF Icon is the initial warning that soot levels are rising in the diesel particulate filter (DPF) ReGen should occur automatically without interference to operations.

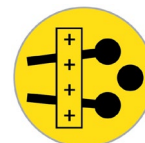

If, however, the engine is shut down before ReGeneration is completed, the next time the engine is started, ReGeneration will be required, and can be initiated by pressing the key associated with the ReGen icon.

For ANY regeneration to take place, the coolant temperature must be at or above 160°F (71°C). If not, the ReGen will not take place.

There are three (3) types of regeneration modes:

- 1) **PASSIVE** – This means the engine is working hard enough to create sufficient exhaust temperatures so that regeneration is taking place without any external assistance. This goes on without any operator intervention; in fact, the operator may not even be aware of it unless he notices the high exhaust temperature light illuminated.
- 2) **ACTIVE** – In this situation, the conditions are close to being correct for a ReGen but the exhaust temp is not quite high enough so the ECU injects some fuel into the exhaust stream to raise the temperature and allow ReGen. Again, this goes on without the need for any outside intervention from external controls and would only be noticed by someone monitoring the exhaust gas temp light.
- 3) **PARKED** – This is the one that requires “special conditions” be met for the ReGen to occur. The engine must be at DPF level 2, 3 or 4 and the park and neutral signals must be sent so the ECU knows the engine is not under any load. (The engine may need to be at LOW idle, which varies from engine to engine). Once those conditions are met, the operator must press the active ReGen button and the control system starts the ReGen.

If an automatic ReGen has not occurred or completed, the operator should immediately perform a Parked, Manual REGEN. DPF level must be at Level 2, 3 or 4 to perform a Parked Regeneration.

CAUTION: Do not operate the unit during a Parked ReGen, this will abort the process.

4.7 Reel Removal and Installation

Make sure there is adequate overhead clearance with no obstructions before attempting to remove or install a reel.

WARNING: Injury or Death: CRUSH HAZARD: Personnel assisting during Drum/Reel removal and installation must wear appropriate PPE and must remain vigilant and ready to quickly move clear of in the event of a load shift or restraint failure. Reel Removal and Installation presents a potential crush hazard. Ensure that all non-essential personnel are clear of the area before lifting and moving the drum.



- 1) Make sure the **PT-3000** is shut down and the key is removed from the ignition switch.
- 2) Disengage the hydraulic motor & gearbox spline
- 3) Disengage the manual payout brakecoupler.
- 4) Remove the locking pins and unlatch the pillow block housing. Rotate the top of the housing to the full open position and make sure the latch is folded back out of the way.
- 5) Use a spreader bar on the chains to the lifting device to lift the reel and drive bar assembly up out of the pillow blockhousing.

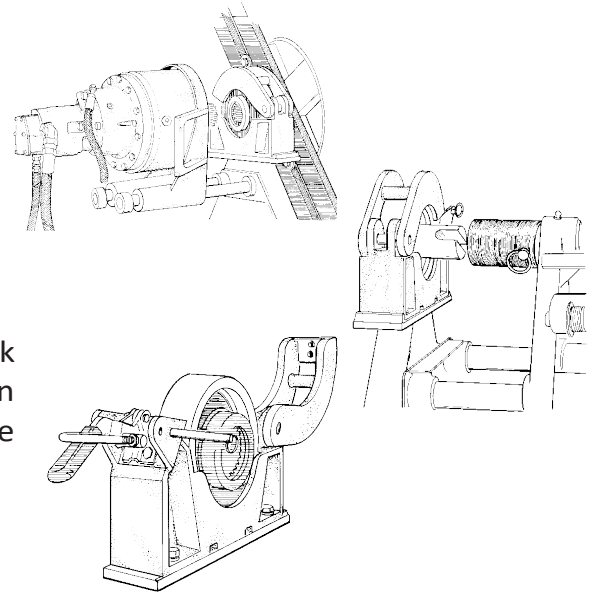

CAUTION: Lift straight up keeping the bar level with the machine to prevent the bearings from binding in the pillow block housings and possibly causing damage to the machine.

- 6) Remove the bearing from the end of the drive bar, loosen the set screws and remove the lifting eye/tapered cone.
- 7) Slide the drive bar into the reel to be installed. Adjust the drive pins if necessary.

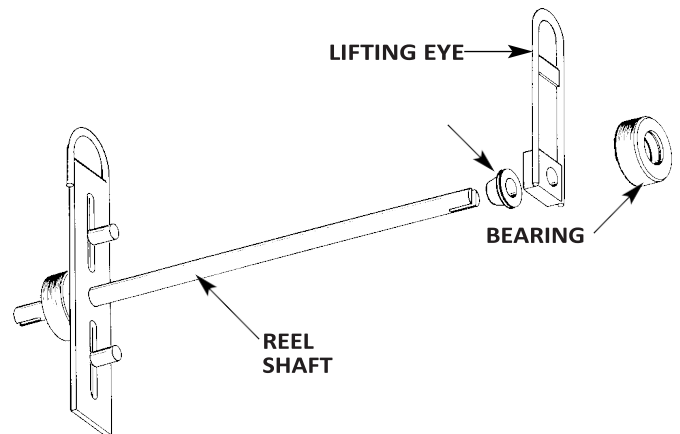

- 8) Slide the reel lifting eye/tapered cone onto the drive bar.

NOTE: The tapered cone is turned in and slid into the arbor hole on wooden reels when necessary to stabilize the reel.

- 9) Align the reel lifting eye with the lifting eye on the drive bar and tighten the set screws.

- 10) Slide the bearing into place on the drive bar.

- 11) Attach the lifting device chains with a spreader bar to the reel and drive bar lifting eyes.

- 12) Position the reel over the pillow block housings and lower the reel into place.

NOTE: Lower the reel straight and level with the machine to keep the bearings from binding in the pillow block housings as the reel is lowered into position.

- 13) Remove the lifting device, close, latch and secure the pillow block housings with the locking pins.

- 14) Rotate the reel by hand to make sure it moves freely and turns correctly.

- 15) Slightly rotate to engage the gearbox spline or payout brake coupler and lock in place with pin(s) as required for the operation method desired, pulling or tensioning.

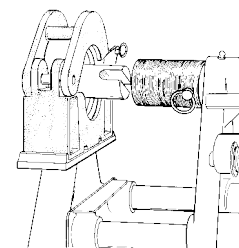
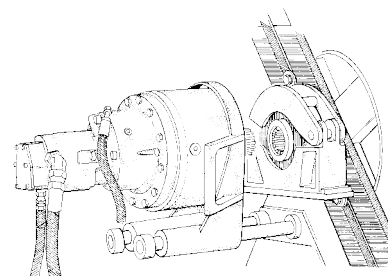
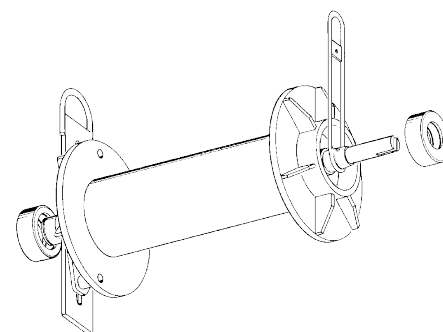
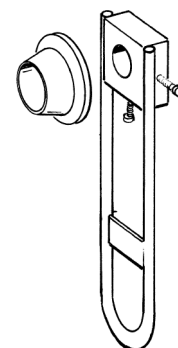

4.8 Payout Operations – PULL Mode

NOTE: Before beginning payout operations, the operator must perform all pre-operation inspections. (See *Pre-Operation Inspection Checklist on page 38.*) Pre-operation inspections are important for the safe operation of the machine and are required under OSHA Regulations.

The PT-3000 is designed to offer two payout operation options: powered and non-powered. The first utilizes hydraulically assisted payout, where the drum drives the line out. This hydraulically assisted payout method is usefully when manually pulling out with a vehicle or “walking out” the line. Additionally, line can be pulled off with the hydraulic motor disengaged and using the manual Walk-Off brake – non-powered.

Power Assisted Payout

For power assisted payout operations, select [PULL] mode on the system control panel. Power assisted payout is useful when manually “walking out” the line.

- 1) The unit should be positioned, anchored, level, and appropriately grounded. (See Positioning the Machine).
- 2) Perform Start-Up Procedure.
- 3) If not done already, remove the rope from the Levelwind.

Disengage the manual payout brake coupler.

- 4) Park the Levelwind out of the way, all the way to the street side (right side when viewed from the cab).
- 5) Select PULL mode on the system control display by pressing the MODE button. This setting is defaulted to whatever was last set for the system. If the system is already in PULL mode, there is no need to change this setting.

- 6) Line Tension may be set to zero but it is not necessary.

NOTE: With the engine running, the hydraulic motor engaged, and the system in PULL mode, the operator can payout (push) line at a speed that is consistent with walking or driving out the line with a vehicle. This is accomplished by using the hydraulic system to drive out the line with minimal or no tension.

- 7) Begin payout operations by depressing the joystick trigger. Pull back slightly on the joystick, bringing it out of neutral, and then pause for the brake to release. Once the brake is released, slowly push forward on the joystick, through neutral while still holding trigger. Once past center/neutral, the trigger should be release. Once the desired speed is reached, the joystick can be released.

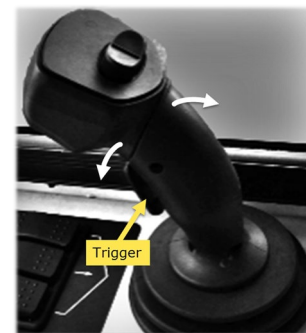
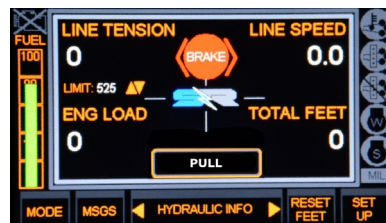
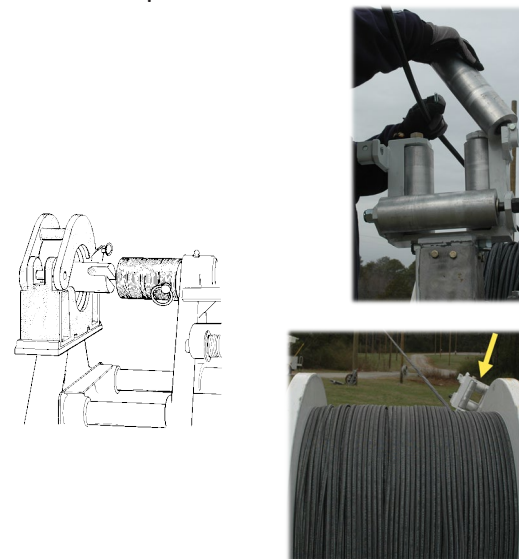

NOTE: The reason the joystick must first be pulled back during payout is that this motion triggers the release of the hydraulic brake and begins the hydraulic pressure building sequence. As soon as the brake releases, the operator will notice the drum beginning to rotate very slowly backward toward the operator. This is also designed to pull any slack out of the line.

8) Continue to monitor the line speed and the footage counter.

NOTE: To stop drum rotation at any time, return the joystick control to the center neutral position **with the joystick trigger released**, and the hydraulic brake will set.

CAUTION: Before handling any pilot, pulling, or conductor lines attached to this machine, the operator must ensure that the hydraulic drum brake is set and the joystick is in the neutral position with the joystick trigger released.

CAUTION: Never payout all of the rope off of the drum. Leave at least one layer of rope wrapped on the drum. Otherwise, the rope end could be pulled from its anchor point.

9) Once the rope is paid out and operations have concluded, place the joystick control into the center neutral position with the trigger released, and ensure that the hydraulic drum brake is set. This will conclude payout operations.

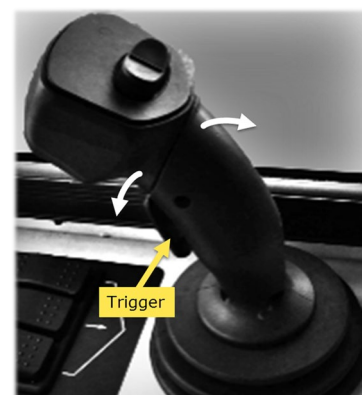
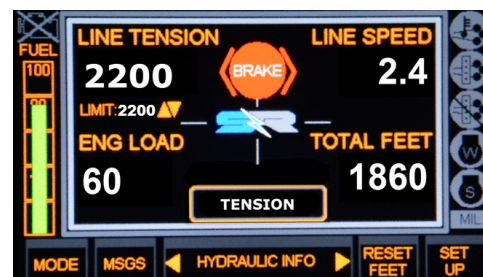

4.9 Payout Operations – Non-Powered

Line can be pulled off with the hydraulic motor disengaged from the reel and the engine and system shut down. The method is essentially a freewheel with a manual, low-tension payout brake (Manual Payout Brake).

NOTE: When pulling the line of with the hydraulic motor disengaged, there is no counter to indicate line length.

4.9.1 Manual Payout Brake

This brake is for low-force, low-tension, below 1000 lb - for pulling, walking, or driving off pulling line/bull line.

NOTE: This brake is not designed to hold tension above 1000 lb.

Attaching the brake and reel coupling sleeve

- 1) To attach the Manual Payout Brake, slide the brake Reel Coupling Sleeve onto the Reel Shaft.

CAUTION: Do not use the Manual Payout Brake for any load that could exceed 1000 lb. Manual Payout Brake should be used only for tensions below 1000 lb.

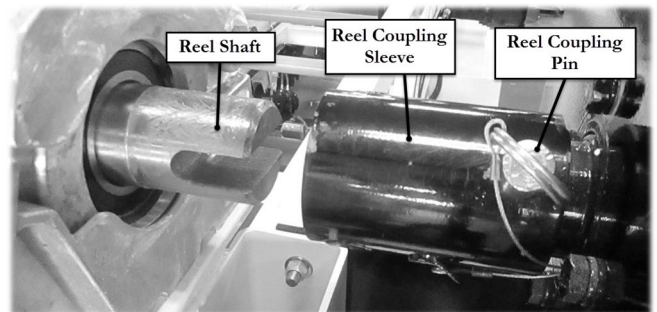

- 2) Secure it with the Reel Coupling pin.

NOTE: S+R recommends that the Manual Payout Brake be remain uncoupled unless being used for walking or pulling of line under low tension.

Failure to uncouple or fully release the Manual Payout Brake may burn up the brake pads and warp the brake rotor.

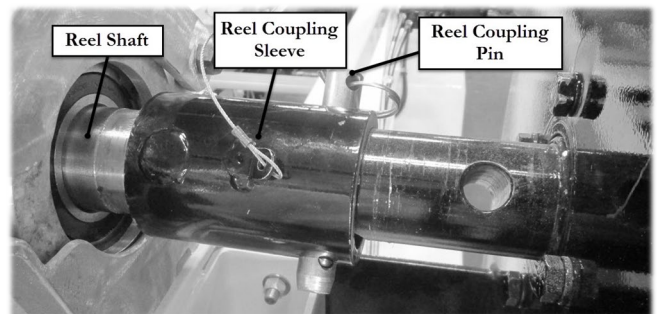

4.9.2 Non-powered Walk-off

- 1) The unit should be positioned, anchored, and appropriately grounded. (See Positioning the Machine).
- 2) If not done already, remove the rope from the Levelwind.
- 3) The Levelwind out of the way, all the way to the street side -right side when viewed from the cab. If necessary, start the unit to move the Levelwind.



- 4) Decrease the Manual Payout Brake pressure to zero.

NOTE: The turn handle for controlling Manual Payout Brake pressure is located on the brake.

- 5) Remove the pins and slide the gearbox spline and hydraulic motor to disengage it.
- 6) Secure the gearbox in the disengaged position with the locking pins.

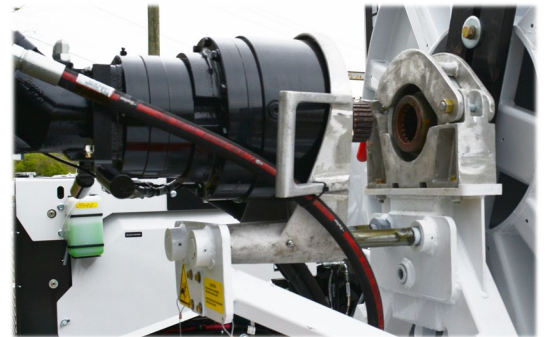

- 7) If needed, Manual Payout Brake pressure can be applied manually at the brake.

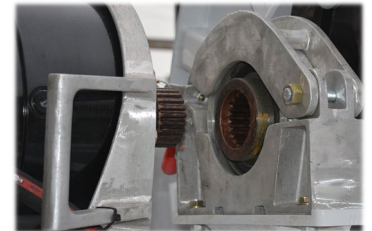

4.10 Pulling

Setup

- 1) The unit should be positioned, anchored, level, and appropriately grounded. (See Positioning the Machine)
- 2) Disengage the manual payout brake coupler.
- 3) Install the pulling drum, if not already installed. (See Reel/Drum installation section.)
- 4) The pulling line/bull line should be already paid out and ready to connect. (See Payout section.)
- 5) Attach the pulling line/bull line to the conductor with pulling grips and pulling swivel. Make sure there is tension on the pulling line so it doesn't drop and release from the securing point.

Engaging the Hydraulic Motor

- 1) Remove the locking pins and slide the gear box spline shaft into the drive bar. Secure the mechanism with locking pins.



- 2) S+R recommends that the Manual Payout Brake be uncoupled. Un-pin and slide the brake coupler back, disengaging it from the drive bar and secure it with the locking pin.

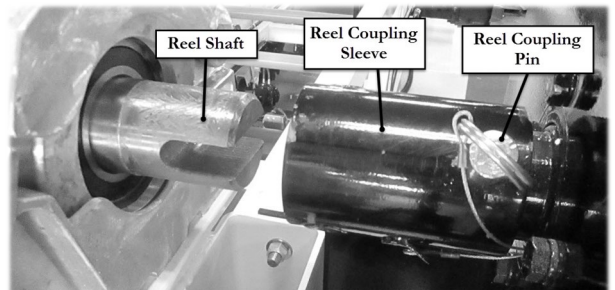

- 3) Using the top joystick lateral rocker switch, adjust the R/L starting position of the levelwind so that the levelwind is centered over the exit rope so it is directly in line with the pulling/bull line as it enters the reel.



- 4) Place the pulling rope through the levelwind head and secure all rollers and retaining pins.



Pulling continued

- 5) At the System Control Panel, switch the unit to [PULL] by pressing the [MODE] button.
- 6) Adjust the Line Tension limit using the Up/Down arrow keys.

NOTE: The tension limits can be adjusted in 100 lb. increments without halting operations by using Up/Down arrow keys on the control panel.



NOTE: Maximum tension in PULL Mode is 3000 lb at the top of the drum. Max tension is higher closer to the drum core - up to 4500 lb.

- 7) Begin pulling by depressing the joystick trigger, then pulling back slightly on the joystick, bringing it out of center/neutral.

Pause briefly for the brake to release. Once the brake releases, release the joystick trigger

Pull backward on the joystick until the desired rotation speed is reached. Once the speed is at the desired level, the joystick itself can be released.

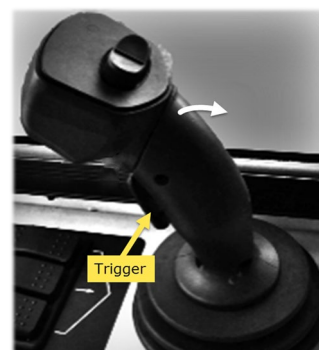

- 8) Manage the lay of the pulling line using the LEVELWIND. The LEVELWIND requires constant operator input. **The Operator controls the lateral side-to-side movement of the LEVELWIND and the turnaround** using the top joystick lateral rocker switch.

NOTE: The Levelwind lateral rocker switch is proportional. The harder it is pressed, the faster the levelwind will move.

CAUTION: Use caution not to extend the levelwind fairlead head beyond of flange of the drum.



- 9) Monitor the adjust the Line Tension and Line Speed as required. Slow the speed using the joystick as pulling grips and swivels enter angles.

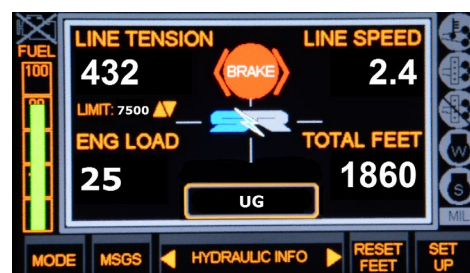

- 10) To STOP, return the joystick to center/neutral position with the trigger released.



4.10.1 Tension

Tensioning

Position the unit in a suitable location where it will be free from obstructions and clear of any apparent hazards, centered on the lead block, and parallel to the line being tensioned. Chock the wheels. Set up as level as possible using the jacks. Install appropriate anchoring and grounding.

- 1) Remove the locking pins and slide the gear box/spline shaft into the drive bar using the large drive screw; Secure the mechanism with locking pins.
- 2) Disengage the Manual Payout Brake coupler.
- 3) Attach the pulling / bull line to the conductor with pulling grips and a pulling swivel.
- 4) Move the levelwind to the side – fully extending the levelwind cylinder. (This will be the StreetSide of the trailer - the operator’s right as he is standing at the control panel; as pictured)
- 5) Start the engine.
- 6) At the System Control Panel, switch the unit to [TENSION] by pressing the [MODE] button. This setting is defaulted to whatever was last set for the system. If the system is already in TENSION mode, there is no need to change this setting.

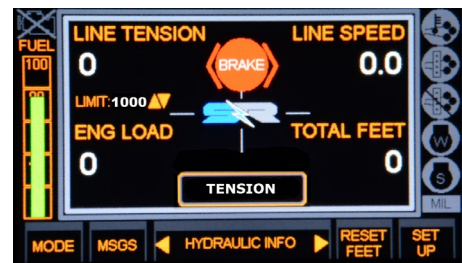
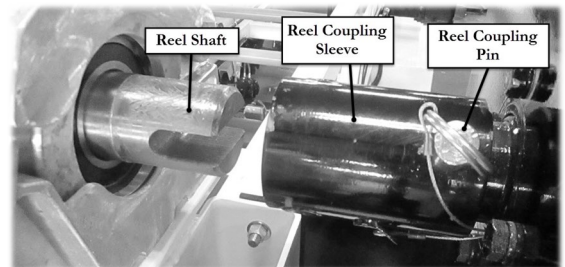

NOTE: Maximum tension is 2200 lb. Minimum tension is 1000 lb.

- 7) Adjust the Line Tension limit using the Up/Down arrow keys. *The amount of tension applied, expressed in lb, is indicated by the gauge.* The tension limits can be adjusted without halting operations by using Up/Down arrow keys on the control panel.

NOTE: When in tensioning mode, the line tension limit functions as the line tension setting. When more or less tension is needed, press the arrow soft-key buttons to change the tension. The tension limits can be adjusted in 25 lb increments. (Hold down the button for faster adjustment) The joystick does not control the amount of tensioned hold-back on the line, as the machine automatically manages the tension applied based on the line tension setting. Maximum tension limit in TENSION Mode is 2200 lb.

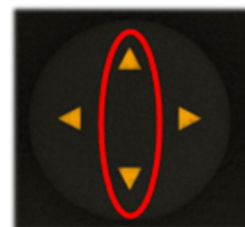

- 8) Begin tensioning operations by depressing the joystick trigger. Pull back slightly on the joystick, bringing it out of neutral, and then pause for the brake to release. Once the brake is released, release the joystick trigger, then continue to pull backward on the joystick until it is all the way back. The joystick can be released.

NOTE: In order to payout line to allow slacking of the line if necessary, the unit must be switched back to PULL Mode.

- 9) Continue to monitor the line speed and footage counter.

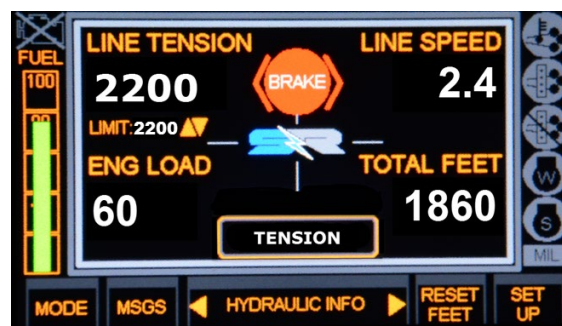

- 10) Once the conductor is paid out and the operations have concluded, place the joystick control into the center/neutral position with the trigger released, and ensure that the hydraulic drum brake is set. This will conclude tensioning payout operations.

4.10.2 Spider System

The Spider System is used to haul a pulling line (“bull rope”) from a pulling unit to a tensioning unit. The rewind system utilizes a levelwind to ensure smooth even distribution of the pilot line onto the spider reel.

To utilize the Spider System:

- 1) At the MAIN Screen at the System Control Panel, go to the SETUP Screen.

- 2) At the SETUP Screen, use the arrow keys to move the highlight box to SPIDER; ON.



- 3) Push the OK button to turn the Spider System ON.

- 4) Press ESC to return to the MAIN Screen which will indicate that the unit is in the SPIDER MODE.

- 5) Begin SPIDER PAYOUT operations by depressing the joystick trigger. Pull back slightly on the joystick, bringing it out of neutral, and then pause for the brake to release. Once the brake is released, slowly push forward on the joystick, through neutral while still holding trigger. Once past center/neutral, the trigger should be release. Once the desired speed is reached, the joystick can be released.

- 6) For SPIDER PULL IN, begin by depressing the joystick trigger, then pulling back slightly on the joystick, bringing it out of center/neutral. Pause briefly for the brake to release. Once the brake releases, release the joystick trigger, pull backward on the joystick until the desired rotation speed is reached. Once the speed is at the desired level, the joystick itself can be released.

- 7) As the spider line/pilot line goes on the reel, use the top joystick lateral rocker switch to move the levelwind control back and forth gradually to wind the cable on the reel evenly.

- 8) To STOP operations, return the joystick to center/neutral position with the trigger released.

NOTE: Speed, Tension, and Total Feet data are not available on the Spider® System nor in SPIDER Mode.

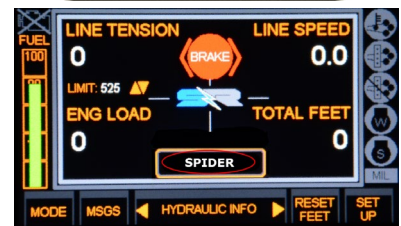

4.11 Underground Connectors

The underground pulling connectors (E-35D: 3000lb and the E-49D: 8000lb) are designed to restrict the rotation and unwinding of the pulling cable. The more load the pulling cable sees, the more resistance the connector sees, thus restricting the rotation of the wire rope. Wire rope cable is made in a spiral or helix, and as tension is applied, the pulling cable tries to unwind. After tension is released, the pulling cable has a memory and tries to return to its original straight design; however, if it goes past its original design, this causes twisting and kinking.

CAUTION: Do not attempt to use overhead line stringing swivels to install underground cable. Not using the correct underground connector will cause damage to the pulling line, and may cause personal injury if the line fails.



Underground Connectors:
E-35D: 3000 lb and E-49D: 8800 lb

Birdcaging and twisted pulling cable can be caused by several factors:

- Wire rope pulling cable specifications not in compliance with puller manufacturer recommendations regarding RBS (rated breaking strength), MWL (maximum working load), and pitch (length of strands at the twist).
- Using overhead swivels and/or using worn underground pulling connectors.
- Pulling cable over too small of a radius sheave (minimum of 15 times the cable diameter) or edge of vault lip.
- Rapid unloading of pulling tension on the pulling cable.
- Overstressing the pulling cable's recommended working load.
- Using pulling grips with built-in swivels (use flex-eye type grips).

Recommended items to improve pulling cable life and Puller operation:

OEM specifications used when replacing pulling cable. Sherman + Reilly has developed a testing procedure and specification assurance with a wire rope manufacturer. This pulling cable is available from stock at Sherman + Reilly at a competitive price - Part Number: 700092.

Our **standard** wire rope pulling cable for the PT-3000 is 3/8-inch steel pulling cable and has an ultimate rating of 15,100 lb. The specification is 3/8" – 6 x 25 XIP (extra improved plow steel) I.W.R.C. (independent wire rope center) RRL (regular right lay).

When the recommended working load of the pulling cable is exceeded, twisting and birdcaging occurs.

We recommend using the specified pulling cable to ensure the pulling cable working load is not exceeded when pulling in underground conductors.

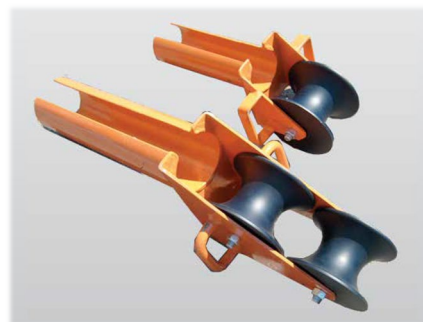

Underground Blocks: UG-71 and UG-72

4.12 Underground Pulling

To use the PT-3000 for pulling underground, the unit must be equipped with: an underground pulling drum containing steel pulling cable. (An optional Pad Mount Transformer Adapter (PMTA) is available.).

Additionally, non-swiveling underground line connector must be used. Never used overhead line swivels or pulling rope for pulling conductor underground. Overhead swivels will cause damage to the steel pulling cable.

Underground Setup and Payout

- 1) Disengage the manual payout brake and engage the hydraulic motor.
- 2) Turn on the unit and start the engine.
- 3) Select UG (Underground) mode on the system control display by pressing the MODE button. This mode setting is defaulted to whatever was last set for the system. If the system is already in UG mode, there is no need to change this setting. The maximum Line Tension limit is 7500 lb.
- 4) The wire pulling cable must be threaded through the rollers on the side of the levelwind and down through the underground rollers. (For the optional PMTA attachment, see the PMTA instructions in the appendix.)
- 5) The steel pulling cable is either blown through the conduit using an ATCC air adapter or pulled through using a pulling line.

NOTE: With the engine running, the hydraulic motor engaged, and the system in PULL mode, the operator is able to payout (push) line. This is accomplished by using the hydraulic system to drive out the line with minimal or no tension.

- 6) If needed, install duct rollers and underground blocks to route the cable so that it does not rub or abrade against the side of the opening, pipe, or duct.
- 7) Check and adjust levelwind (or PMTA if installed) and unit position as needed.
- 8) Begin payout operations by depressing the joystick trigger. Pull back slightly on the joystick, bringing it out of neutral, and then pause for the brake to release. Once the brake is released, slowly push forward on the joystick, through neutral while still holding trigger. Once past center/neutral, the trigger should be release. Once the desired speed is reached, the joystick can be released.

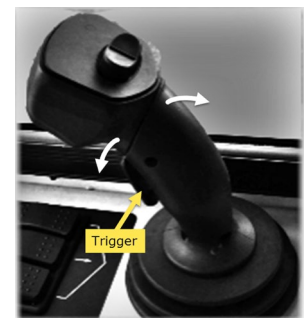
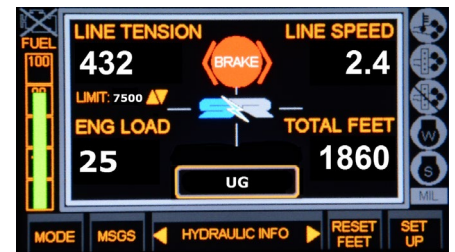

Underground Pull

Engine is running. Hydraulic fluid is warmed-up.

- 1) The hydraulic motor is engaged. (See Engaging the Hydraulic Drive Motor.)
- 2) System is in "UG" Mode.

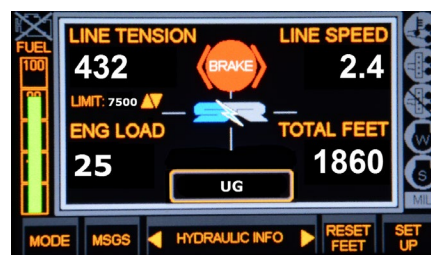

- 3) Set the desired maximum Tension Limit.

NOTE: The tension limits can be adjusted without halting operations by using Up/Down arrow keys on the control panel.



- 4) Begin pulling in cable by depressing the joystick control trigger and slowly pulling back on the joystick to release the brake and until the desired speed is reached. Once the speed is reached the operator can release the joystick.
- 5) Continue to monitor the tension, speed, hydraulic system pressure, and payout footage counter.
- 6) Once the cable reaches within its last 30 feet of length, begin to slow the winch speed by pushing the joystick forward.
- 7) Once the cable reaches within its last 15 feet of length, bring the drum to a complete stop by pushing the joystick all the way back to center/neutral, which will engage the brake.
- 8) If cable end has not exited the underground opening, reengage pulling. Once the cable end has cleared the underground opening stop the winch by pulling back on the joystick.
- 9) Remove the conductor pulling grip from the conductor and swivel. Also, remove the swivel from the cable end.
- 10) Once completed with pulling operations, fully retract the cable and tie-down or restrain the cable
- 11) Complete all appropriate post-operations and inspections.

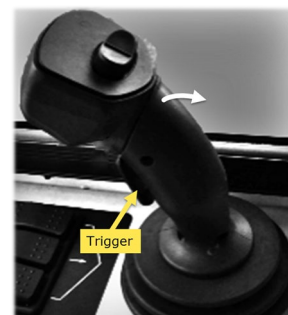

CAUTION: Over time, and through regular use, the painted indicators on the pulling cable will begin to degrade. Maintaining the painted indicators is recommended. However, the operator should always monitor the payout footage counter, located on the winch operations screen, during operations.

CAUTION: Do not use excessive speed or pressures when pulling underground. Use only enough pulling pressure, "line tension" to turn the drum. Unnecessary high pressure settings prevent the unit from sensing problems such as the conductor getting stuck during the pull. Excessive pulling speed will create higher tension and increase safety risks to personnel on the job site.

4.13 Post-Operation Inspection Checklist

- When parking the machine, the wheels should be chocked
- Check engine oil, radiator coolant, and hydraulic fluid levels- to ensure no leakage after operations.
- Store all grips, blocks, and other tools/equipment used during operations back into the tool box. Then close and lock tool box.
- Secure all rope/conductor ends to the reel using a tie- off rope around the reel or an industrial zip tie.
- Remove the keys from the control panel, and shut and lock the control panel box.
- Lock all engine panels.
- Remove any trash, rags, or other loose material from the machine.

Storage:

For periods of extended storage without use, the batteries will need to be periodically charged. A low amperage “trickle” charger can be used periodically to maintain proper battery charge during periods of extended storage.

During extended storage, the trailer tire pressures should be periodically monitored, as heavy trailer weight on low tires can create permanent buckling of the tire sidewall resulting in the need for tire replacement. Always see the specified air psi. ratings listed on the tire sidewall.

NOTE: It is necessary to open the engine covers to check the fluid levels. Be sure all covers are closed and latched in position properly before transport or operating the machine. If machine is to be parked in a publically accessible area, the engine compartments must be secured.

NOTE: Post-operation checklist should be conducted in accordance with OSHA requirements, to include OSHA Standard- 29 CFR, Part 1926.600.

NOTE: In order to help prevent rust on the unit, it is important to regularly apply a corrosion inhibitor / lubricant like TC-11 Corrosion Inhibitor or equivalent to exposed metal as well as fairlead rollers and pins. If the unit is stored outdoors, the product should be reapplied every 6 months. The product should also be reapplied if a visual inspection indicates that surface areas are no longer glossy. The friction between the cable and the surface of the reel and rollers can accelerate the degradation of any corrosion inhibiting coating, therefore, the reel and rollers should be examined after each use to determine if reapplication would be beneficial.

5 Troubleshooting

Quick Tips

ENGINE WILL NOT START OR RUN

- Dead battery.
- No fuel- check fuel gauge.
- Other- Refer to engine manufacturer's manual.

DRUM WILL NOT ROTATE

- Low system pressure drum clutch not releasing.
- Drum clutch out of adjustment.
- Obstruction between drum and frame.
- Existing line tension in excess of line tension limit setting.

HYDRAULIC JACK CREEPS DOWN

- If motor is running, control valve seals are bad.
- Motor off, or holding valve on jack is malfunctioning.

UNIT WILL NOT BUILD MAXIMUM HYDRAULIC SYSTEM PRESSURE

- Control valve blocked or malfunctioning.
- Pump relief valve malfunctioning.
- Pump failure.
- System pressure relief valve at the pump out of adjustment or malfunctioning.
- Contamination in hydraulic system.
- Wiring damage to pump actuators.

HYDRAULIC FLUID TEMPERATURE IS ABOVE NORMAL

- Drum clutch not fully releasing.
- Contamination in hydraulic system.
- Wiring damage to the hydraulic cooling system- fan, wiring, coil, or sensor.

TRAILER LIGHTS DO NOT WORK AFTER CONNECTED TO VEHICLE

- Check vehicle/trailer wire connectors for damage or corrosion.

Service & Repair

NOTE: For service or repair please contact the Sherman + Reilly™ Parts & Service at **800-251-7780** or **(423)756-5300**, via email at help@sherman-reilly.com, or via our website: www.sherman-reilly.com

Equipment Information	
Company Name:	_____
Date of Purchase:	_____
Date of Manufacture:	_____
Equipment/Unit Model Number:	_____
Equipment/Unit VIN Number:	_____
Engine Serial Number:	_____

Major Fault:

A “major fault” describes a system malfunction or other system degradation that, by equipment failure, operator error, or other environmental condition, renders that machine inoperable. A major fault can be identified when, through normal operations, the machine would create; an unsafe condition, further or permanent equipment damage, or other situations deemed outside of the operator’s ability to effectively and safely operate the machine.

When to send for Service or Repair:

If after troubleshooting an issue or fault that cannot be resolved, or a major fault has been identified, the operator should stop all operation attempts and contact the Sherman + Reilly™ Parts & Service Department at **800-251-7780** or **(423)756-5300**, via email at help@sherman-reilly.com, or via our website: www.sherman-reilly.com. Further operation should not continue until the issue or fault is resolved.

This manual and the information contained herein is for the use of the owners, operators, and service personnel of Sherman + Reilly™ equipment and is licensed to such end users as “Licensee”. Licensee agrees not to reverse engineer, decompile, disassemble or otherwise attempt to derive the techniques, processes, know-how, or other engineering, computational, or operational information from this machine (collectively, “Reverse Engineering”) or permit or induce the forgoing beyond requisite service and maintenance requirements. Any information supplied to or obtained by Licensee under this agreement may only be used by the Licensee for the purpose of operating, servicing, maintaining, and repairing said Sherman + Reilly™ equipment and must not be disclosed to any third party or used to create any machine which is substantially similar to said Sherman + Reilly™ equipment.

© Copyright 2018 Sherman + Reilly™ Inc. 400 West 33rd Street, Chattanooga, TN 37410



**We're dedicated to getting every lineman home
every night, no exceptions**

Follow Sherman + Reilly™!



609289

Rev B

0818

©2018 by Sherman + Reilly™ Inc. | 400 W 33rd Street, Chattanooga, TN 37410 USA | www.sherman-reilly.com

All rights reserved Sherman + Reilly™, Inc.

This material is proprietary to Sherman + Reilly™ Inc. and is not to be reproduced, used, or disclosed except in accordance with written authorization from Sherman + Reilly™ Inc. Information is provided for the purpose of product usage and maintenance descriptions only. The descriptions and specifications in this manual are subject to change without notice, and to the best of our knowledge, are accurate at the time of printing. The information contained may not be specific to all models or units, and must not be construed as warranted characteristics in the legal sense. The information does not relieve users from the duty of conducting their own inspections and evaluations. The information contained represents the best practices for the safest use and maintenance of the machine/unit, and does not cover every situation. With regard to situations not covered in this manual, the operator is responsible to ensure the safe operation of the machine and should ask questions or make inquiries if uncertainty exists prior to the operation of the machine or unit. Sherman + Reilly™ Inc. reserves the right to continually improve and expand our product line. It is our policy to improve our products whenever it is possible and practical to do so. We reserve the right to make changes or improvements at any time without incurring any obligation to install such changes on products sold previously. As our products are subject to continual improvement, we reserve the right to amend the product specifications, maintenance steps, and all information contained in this manual. Some product improvements may have taken place after this manual was published. For the latest information on Sherman + Reilly™ products, contact us by phone at (423) 756-5300 or 1-800-251-7780 or via email at help@sherman-reilly.com or at the mailing address listed above.