



# Operator's Manual

VST-36/40/47/52-I

## Aerial Device

SERIAL NUMBER

MANUAL PART NUMBER

 PLEASE NOTE THE ANSI A92.2 STANDARD AND THE MANUAL OF RESPONSIBILITIES CONTAINS RECENTLY UPDATED INFORMATION. DEALERS, OWNERS, USERS, OPERATORS, LESSORS AND LESSEES MUST ADHERE TO THESE UPDATED STANDARDS.

### ATTENTION:

 DO NOT ATTEMPT TO OPERATE THIS VERSALIFT UNTIL YOU HAVE READ AND UNDERSTOOD ALL INFORMATION IN BOTH OPERATOR'S AND SERVICE MANUALS, PROVIDED WITH EACH VERSALIFT.

 THIS MANUAL CONTAINS CONFIDENTIAL INFORMATION AND IS THE SOLE PROPERTY OF TIME MANUFACTURING CO. CONTENTS ARE NOT TO BE DISCLOSED, COPIED, OR REPRODUCED IN ANY MANNER WITHOUT THE EXPRESSED, WRITTEN PERMISSION OF TIME MANUFACTURING CO.



Time Manufacturing Co. 7601 Imperial Drive P.O. Box 20368 Waco, Texas 76702 Phone: 254-399-2100 Fax: 254-751-0775

Time Manufacturing Co. reserves the right to improve the design or change specifications at any time without notice.



TIME MANUFACTURING COMPANY  
PO BOX 20368  
WACO, TEXAS 76702  
www.timemfg.com

**MODEL** VST-52I

**SERIAL NO** \_\_\_\_\_

**THIS BOOM IS: INSULATED**  **NON-INSULATED** \_\_\_\_\_

**CATEGORY** C **RATED LINE VOLTAGE** 46 kV

**CONFIGURED FOR ELECTRICAL WORK RUBBER GLOVING: YES**  **NO** \_\_\_\_\_

**CHASSIS INSULATING SYSTEM: YES**  **NO** \_\_\_\_\_

**RATED LOAD CAPACITY:**

*This Aerial Device Complies with the Requirements of ANSI/SAIA A92.2 and/or CAN/CSA-C225*

Unit equipped with 1 platforms

Platform capacity is 500 lbs. 227 kg per bucket or platform

**UNIT EQUIPPED WITH UPPER CONTROLS WITH HIGH ELECTRICAL RESISTANCE: YES** \_\_\_\_\_ **NO**

**UNIT EQUIPPED WITH MATERIAL HANDLING ATTACHMENT: YES**  **NO** \_\_\_\_\_

**AERIAL DEVICE SYSTEM PRESSURE** 3000 **PSI** 210 **kg/cm<sup>2</sup>**

**AERIAL DEVICE CONTROL SYSTEM VOLTAGE** 12 Vdc

**AMBIENT OPERATING TEMPERATURE RANGE** -40°F to 120°F (-40°C to 49°C)



### OWNER'S WARRANTY

The **Versalift** Aerial Platform Lift is engineered and designed to perform as stated on published specifications. Only quality material and workmanship are used in the manufacture of this product. With proper installation, regular maintenance, and periodic repair service, the equipment will provide excellent service.

Those parts of the **Versalift** that are manufactured by **Time Manufacturing Company** are warranted for one full year from date of purchase. Structural components will carry a lifetime warranty for defects in material and workmanship which existed at the time of initial delivery, wear components are not covered by this statement. This warranty is issued only to the original purchaser and promises that **Time Manufacturing Company** manufactured products are free from defects in material and factory workmanship when properly installed, serviced, and operated under normal conditions, according to the manufacturer's instructions.

Manufacturer's obligation under this warranty is limited to correcting without charge at its factory any part or parts thereof which shall be returned to its factory or one of its Authorized Service Stations, transportation charges prepaid, within one year after being put into service by the original user, and which upon examination shall disclose to the Manufacturer's satisfaction to have been originally defective. Correction of such defects by repair to, or supplying of replacements for defective parts, shall constitute fulfillment of all obligations to original user.

This warranty shall not apply to any of the Manufacturer's products which must be replaced because of normal wear, which have been subject to misuses, negligence or accident, or which shall have been repaired or altered outside of the Manufacturer's factory (unless authorized by the Manufacturer in writing), products which have not been maintained and operated in accordance with Time Manufacturing Company's operators, maintenance manuals and bulletins, products which are repaired without using original Time Manufacturing Company parts. This limited warranty does not cover transportation fees and/or consumables used for the repair. Products or parts manufactured by others are covered only by such warranties as are extended to TIME MANUFACTURING CO. by its suppliers.

Manufacturer shall not be liable for loss, damage, or expense directly or indirectly from the use of its product or from any cause.

The above warranty supersedes and is in lieu of all other warranties, expressed or implied, and of all other liabilities or obligations on part of Manufacturer. No person, agent, or dealer is authorized to give any warranties on behalf of the Manufacturer or to assume for the Manufacturer any other liability in connection with any of its products unless made in writing and signed by an officer of the Manufacturer.



# TABLE OF CONTENTS

|  |                  |
|--|------------------|
| <b>Introduction</b>  | <b>Section 1</b> |
| Manual Structure .....   | 1-1              |
| Additional Manual Features .....   | 1-1              |
| Nomenclature .....   | 1-2              |
| <b>Responsibilities / Safety</b>   | <b>Section 2</b> |
| Responsibilities of Dealers, Owners, Users, Operators, Lessors and Lessees ..... | 2-1              |
| Decals .....   | 2-2              |
| Think Safety .....   | 2-5              |
| What is Insulated and What is not Insulated .....                                | 2-8              |
| Additional Safety Considerations .....   | 2-9              |
| <b>Specifications</b>  | <b>Section 3</b> |
| VST-I General Specifications .....   | 3-1              |
| VST-I Option Specifications .....  | 3-2              |
| VST-I Dimensional Specifications .....   | 3-5              |
| VST-I Vehicle Specifications .....   | 3-14             |
| <b>Operation</b>   | <b>Section 4</b> |
| Positioning the Versalift for Operation .....                                    | 4-1              |
| Aerial Lift Operations .....   | 4-2              |
| Cab Control Operation .....  | 4-4              |
| Ground Control Operation .....   | 4-4              |
| Lower Control Operation .....  | 4-5              |
| Upper Control Operation .....  | 4-7              |
| Storing the Aerial Lift .....  | 4-9              |
| Lifting Eye (Option) .....   | 4-10             |
| Manual Jib Operation (Option) .....  | 4-10             |
| Hydraulic Jib Operation (Option) .....   | 4-12             |
| <b>Emergency Operation</b>   | <b>Section 5</b> |
| <b>Daily Visual Inspection</b>   | <b>Section 6</b> |

# INTRODUCTION

The **Versalift** aerial device has been designed and engineered to conveniently place personnel at work stations above the ground. This aerial device, as manufactured, meets or exceeds all applicable ANSI A92.2. Full controls at the platform and complete freedom of boom movements make the **Versalift** a truly flexible and functional work platform.

**NOTE: As the aerial device users, you must read, understand, and follow the instructions in this manual and other manuals supplied with this aerial lift unit.**

This manual is furnished to provide practical and essential information for efficient operation of the **Versalift** aerial device. Proper operation of this aerial lift is the responsibility of the operator and requires a thorough understanding of its capabilities. Personnel responsible for the operation of the aerial lift must be familiar with and understand this manual.

**THIS MANUAL CONTAINS CONFIDENTIAL INFORMATION AND IS SOLE PROPERTY OF TIME MANUFACTURING, AND IS NOT TO BE DISCLOSED, COPIED, OR REPRODUCED WITHOUT EXPRESSED PERMISSION OF TIME MANUFACTURING.**

In addition to, dealers, owners, operators, renters, lessors and lessees are required to comply with the requirements of the applicable section or sections found in ANSI A92.2.

**NOTE: For additional safety information and required responsibilities, refer to the accompanying EMI Safety Manual and Manual of Responsibilities.**

Detailed information for the maintenance inspection and service of the **Versalift** aerial device can be found in the accompanying Service Manual. Should further installation information be required, contact your local **Versalift** dealer or **Time Manufacturing Company**.

**⚠ DANGER: THIS EQUIPMENT SHOULD BE OPERATED AND SERVICED ONLY BY COMPETENT PERSONNEL FAMILIAR WITH GOOD SAFETY PRACTICES. THIS INSTRUCTION IS WRITTEN FOR SUCH PERSONNEL AND IS NOT INTENDED AS A SUBSTITUTE FOR ADEQUATE TRAINING AND EXPERIENCE IN SAFE PROCEDURES FOR THIS TYPE OF EQUIPMENT.**

**⚠ DANGER: READ AND UNDERSTAND THIS MANUAL BEFORE ATTEMPTING TO OPERATE THIS AERIAL DEVICE.**

The manual identifies all the controls and their locations and describes how the controls function.

Routine preventive maintenance is very important in maintaining reliable aerial lift service. A preventive maintenance schedule is provided and must be understood and followed by all operators.

**⚠ DANGER: THIS IS NOT MAINTENANCE FREE EQUIPMENT.**

**NOTICE: THIS MANUAL IS A PERMANENT PART OF THE VERSALIFT AERIAL DEVICE AND MUST REMAIN WITH THE UNIT ALWAYS.**

**Time Manufacturing Company** reserves the right to improve the design or specifications at any time without any obligation to incorporate new features into products previously sold.

## MANUAL STRUCTURE

This manual is divided into six, numbered chapters. The first number in the page number at the bottom of each page identifies the chapter number. Chapter tabs, with titles printed on them, allow easy location of the desired subject.

## ADDITIONAL MANUAL FEATURES

**Danger, caution, and warning** notes are indented, bold faced, and separated from the regular text to emphasize their importance and the need for attention.

English measurements are followed by equivalent metric measurements in parenthesis.

Non-critical units of measure are usually rounded-off to the nearest whole unit.

Notes referring the reader to related information in the manual indicate the chapter or a section of a chapter, not to a single page. The reader may need to scan a few pages to find the needed information.

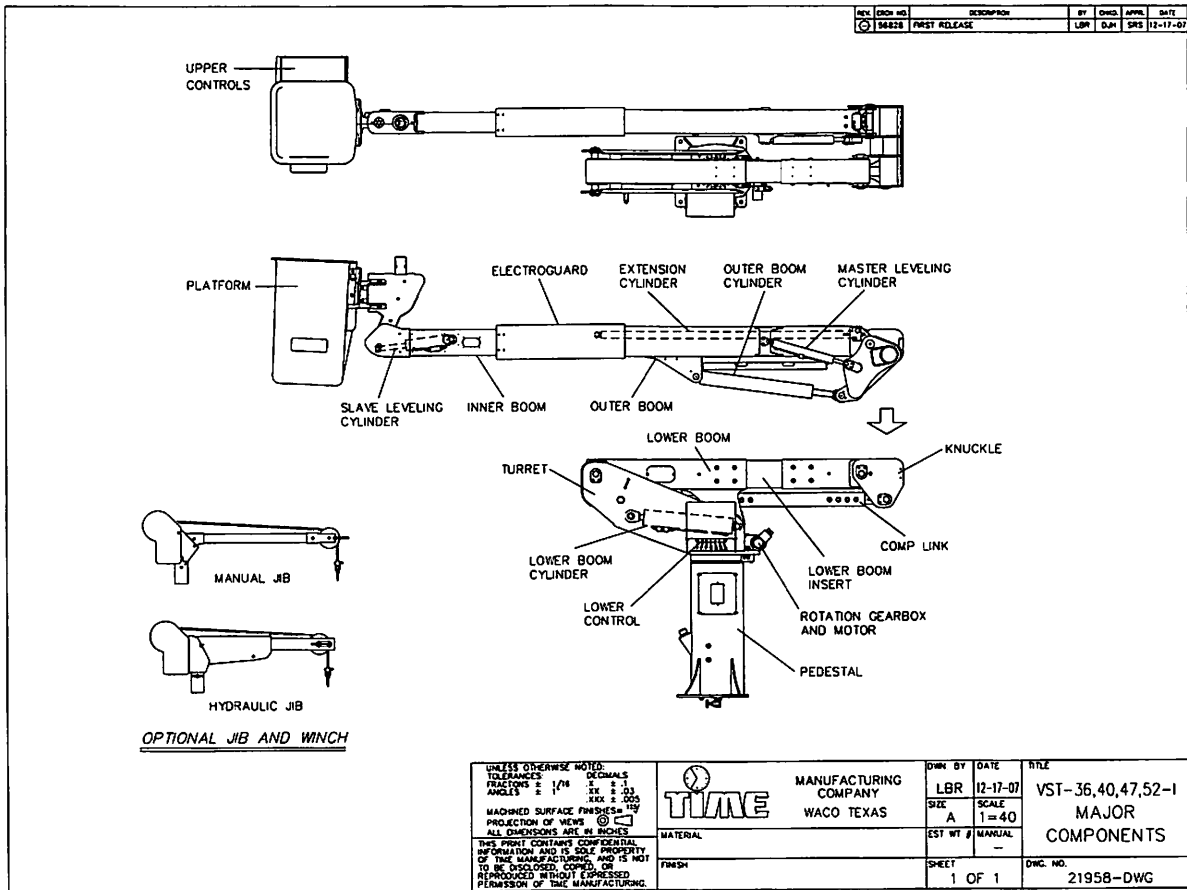

Figure 1.1 Model VST-36/40/47/52-I Nomenclature

# RESPONSIBILITIES

(for Dealers, Owners, Users, Operator, Lessors and Lessees)

**⚠ DANGER: FAILURE TO COMPLY WITH YOUR REQUIRED RESPONSIBILITIES IN THE USE AND OPERATION OF THE AERIAL DEVICE COULD RESULT IN DEATH OR SERIOUS INJURY.**

## IMPORTANT

You are required by ANSI/SIA A92.2 to read and understand **YOUR RESPONSIBILITIES** before you use or operate the Aerial Device. It is your responsibility and your employer's responsibility to identify and comply with applicable codes, standards, and regulations.

The operation of any aerial device is subject to certain **HAZARDS** that can be protected against only by the exercise of **INTELLIGENCE, CARE AND COMMON SENSE**. It is essential to have **COMPETENT, CAREFUL PERSONNEL, TRAINED** in the **INTENDED USE, SAFE OPERATION, MAINTENANCE AND SERVICE** of this type of equipment.

The **USER and OPERATOR MUST MAKE DECISIONS** on the maintenance, use and operation of the Aerial Device with due consideration for the fact that the **SAFETY OF THE OPERATOR AND OTHER PERSONNEL** is dependent on those decisions. **FAILURE TO COMPLY** with your **REQUIRED RESPONSIBILITIES** in the use and operation of the Aerial Device could result in **DEATH OR SERIOUS INJURY**.

**⚠ DANGER: READ AND UNDERSTAND THIS MANUAL BEFORE ATTEMPTING TO OPERATE THIS AERIAL DEVICE.**

# SAFETY

Only properly trained operators are qualified to operate the **Versalift** aerial lift. Operator training shall include complete instruction and understanding of the manufacturer's manuals, employer's work rules, and all related governmental regulations. Prior to operation from the platform the machine must be operating properly, must have been installed properly, inspected, and maintained in accordance with the manufacturer's instructions. All safety signs, guards, and covers must be in place and in proper condition.

**⚠ DANGER: AN UNTRAINED OR CARELESS OPERATOR SUBJECTS HIM/HERSELF AND OTHERS TO DEATH OR SERIOUS INJURY.**

Throughout this manual there are **danger, warning, and caution** notes that emphasize the possible hazards when operating the **Versalift**. It is the responsibility of the operator to become familiar with the contents of this manual.

Two of the main risks associated with operating an aerial lift:

- (1) Electrocution caused by operating too close to power lines.
- (2) Injuries caused by falling as a result of equipment failure or the operator performing an unsafe or unstable maneuver.

No manual can address every conceivable operating hazard. Therefore, the prevention of accidents is greatly dependent upon good judgement and common sense of the operator.

It is the responsibility of the operator to use the **Versalift** only when it has been installed and maintained in accordance with the manufacturer's manuals. The preventive maintenance program outlined in this manual and the Service manual must be followed.

It is extremely important for the operator to be thoroughly familiar with the **Versalift** aerial device. Study the information in this manual and the **Versalift** controls until both are completely mastered. Then go to a large, open area to practice using the aerial lift.

Decals are installed at numerous locations on the aerial lift to warn personnel of the potential hazards during the use and operation of the aerial lift. It is important that the operator and ground personnel read and understand the information on the decals. If any decals are defaced, illegible or lost, they must be replaced. Refer to the "Decal Placement" illustration in this manual for a complete listing and the locations

of the decals. For your convenience these decals are pictured on the following pages as a quick reference for reviewing safety concerns and for providing part numbers when ordering replacements.

## DECALS

All the warning and instruction decals, and their respective part numbers, on the **Versalift** aerial device are included below and on the following pages. The decals are not shown at actual size.

| VERSALIFT AERIAL DEVICE   |   |  |                                 |   |
|---|---|--|---------------------------------|---|
| <b>VERSALIFT</b>  | Model <input type="text"/>  | Serial number <input type="text"/>                       | Date m/y/d <input type="text"/> |   |
| TIME MANUFACTURING COMPANY<br>PO BOX 20368<br>WACO, TEXAS 76702<br>www.versalift.com  | Number of platforms <input type="text"/>  | Electrical system voltage <input type="text"/>           | Vdc                             |   |
|   | Capacity per platform (See manual and decals for specific capacity) <input type="text"/>  | Lbs <input type="text"/>                                 | Kg <input type="text"/>         |   |
|   | Platform height <input type="text"/>  | Ft <input type="text"/>                                  | M <input type="text"/>          |   |
|   | The boom is insulated <input type="checkbox"/> Yes <input type="checkbox"/> No  | Hydraulic system operating pressure <input type="text"/> | Psi <input type="text"/>        | Kg/Cm <sup>2</sup> <input type="text"/> |
|   | Chassis insulating system <input type="checkbox"/> Yes <input type="checkbox"/> No  | Dielectric category <input type="text"/>                 |                                 |   |
|   | Equipped with high electrical resistance upper controls <input type="checkbox"/> Yes <input type="checkbox"/> No  | Rated line voltage <input type="text"/>                  |                                 |   |
|   | Configured for electrical work rubber gloving <input type="checkbox"/> Yes <input type="checkbox"/> No  | Date of Qualification test <input type="text"/>          |                                 |   |
|   | Unit equipped for material handling <input type="checkbox"/> Yes <input type="checkbox"/> No  | Date of Stability test <input type="text"/>              |                                 |   |
|   | Outriggers are required for stability <input type="checkbox"/> Yes <input type="checkbox"/> No  | Installed by <input type="text"/>                        |                                 |   |
|   | <b>OPERATING INSTRUCTIONS</b> Before operating this unit, read and understand all operating and safety information in manual and all information on this placard. |  |                                 |   |
| <ol style="list-style-type: none"> <li>1. Always park vehicle as nearly level as possible.</li> <li>2. When working on a slope, drive into or back into position.</li> <li>3. Do not operate this unit on a slope without proper vehicle stability. Refer to the Operator's manual or fixed decals for stability requirements.</li> <li>4. Inspect this device for visible defects or loose objects.</li> <li>5. Inspect insulating boom and other insulating material for cleanliness, if applicable.</li> <li>6. Set vehicle parking brakes and chock wheels.</li> <li>7. Engage hydraulic power source.</li> <li>8. Extend outriggers, if so equipped, to a solid footing.</li> <li>9. Raise booms sufficiently to clear obstructions on truck before rotating.</li> <li>10. Operate all hydraulic controls smoothly and avoid quick reversal.</li> <li>11. Inspect and service unit per instructions in Service and Installation Manual.</li> </ol> |   |  |                                 |   |
| Ambient operating temperature range<br>-40°F to 120°F (-40°C to 49°C)   |   | This unit complies with ANSI A92.2 and CSA C225          |                                 |   |

1006486-1 & 1006487-1 (DATA BACKING)

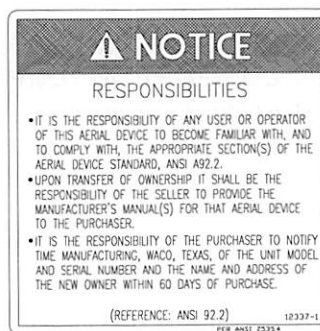

12337-1



14015-X

RESPONSIBILITIES / SAFETY





**WARNING**



**Crush Hazard**  
Contact with moving outriggers can result in death or serious injury.

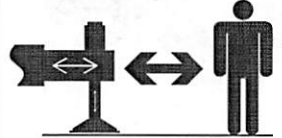

Do not operate outrigger controls unless all personnel are clear of outrigger path and contact point.

12341-1 PER ANSI Z336.4

12341-1

**WARNING**



**Fall Hazard**  
Falling can result in death or serious injury.



Wear approved personnel fall protection equipment and attach lanyard to the anchor provided.  
Read and understand operator's manual.

14014-1 PER ANSI Z336.4

14014-1

**DANGER**



**Electrocution Hazard**  
THIS PLATFORM IS NOT INSULATED. Contact with or inadequate clearance to electrical power lines will result in death or serious injury.



1. Install insulating liner in basket.
2. Perform work in accordance with applicable governmental regulations.

14110-1 PER ANSI Z336.4

14110-1

**DANGER**

FAILURE TO OBEY THE FOLLOWING WILL RESULT IN DEATH OR SERIOUS INJURY

- FOR STATIONARY OPERATION, TRUCK MUST BE SECURELY PARKED, DRIVELINE DISENGAGED, AND AERIAL DEVICE PROPERLY STABILIZED PRIOR TO OPERATION.
- TO AVOID TIP-OVER, OUTRIGGERS (WHEN SO EQUIPPED) MUST BE PROPERLY EXTENDED TO A SOLID LEVEL SURFACE.
- OPERATE ALL CONTROLS SLOWLY FOR A SMOOTH PLATFORM MOTION. MAKE SURE CONTROLS ARE RETURNED TO NEUTRAL AFTER DESIRED OPERATION.
- CREW MUST USE PROPER PERSONAL AND OTHER PROTECTIVE EQUIPMENT.
- NEVER LOAD BEYOND RATED CAPACITY.
- NEVER OPERATE AERIAL DEVICE WITH PERSONNEL UNDER BOOM OR LOAD.
- NEVER MOVE THE TRUCK UNTIL THE BOOMS AND OUTRIGGERS ARE PROPERLY STOWED AND SECURED.
- REFER TO THE OPERATOR'S MANUAL FOR COMPLETE INSTRUCTIONS. IF IT IS MISSING, OBTAIN A NEW ONE FROM TIME MANUFACTURING, P.O. BOX 20368, WACO, TX., 76702

4542-5 PER ANSI Z535.4-1991

4542-5

**DANGER**



**Electrocution Hazard**  
Contact with lines or components at different potential will result in death or serious injury.



Maintain minimum approach distances and use appropriate PPE, tools, and work methods. Allow for boom, platform, electrical line and load line sway. All components above insulated section must be considered electrically connected. Never simultaneously contact platform controls, lines or components at different potentials.

4542-4 PER ANSI Z336.4

4542-4

**WARNING**



**Crush Hazard**  
Contact with moving outriggers can result in death or serious injury.



Stay clear of moving outriggers.

4992-1 PER ANSI Z336.4

4992-1

**CAUTION**

- ALWAYS LOWER THE LOWER BOOM FULLY BEFORE STOWING THE UPPER BOOM.

13144-1

13144-1

**DANGER**



**Electrocution Hazard**  
This equipment may be energized during operation. Contact with energized vehicle will result in death or serious injury.



**STAY CLEAR** of machine.

4542-2 PER ANSI Z336.4

4542-2

**WARNING**



Improper operation or maintenance of this equipment can result in death or serious injury.



Read and understand operator's manual, all safety signs, and capacity charts before using or maintaining machine. If you do not understand the information in the manuals, consult your supervisor, the owner or the manufacturer. It is the user's responsibility to follow manufacturer's instructions on machine operation, service and application, and observe pertinent laws and regulations.

4542-12 PER ANSI Z336.4

4542-12



35409-1 PER ANSI Z535.4

**⚠ DANGER**

**Electrocution Hazard**

Death or serious injury may result if chassis becomes energized. Do not operate the aerial device while creating a path to the ground.

35409-1

7500-1 PER ANSI Z535.4-1991

**⚠ DANGER**

IMPROPER HOLDING VALVE ADJUSTMENT WILL RESULT IN DEATH OR SERIOUS INJURY

1. LOOSENING HOLDING VALVE WITH BOOMS ELEVATED WILL CAUSE UNCONTROLLED BOOM MOVEMENT, DEATH OR SERIOUS INJURY MAY OCCUR.
2. REFER TO SERVICE MANUAL BEFORE PERFORMING HOLDING VALVE MAINTENANCE.

7500-1

11446-1 PER ANSI Z535.4

**⚠ DANGER**

- Do not depend on the jib pole for insulation unless the jib has been rated, tested, and maintained for the appropriate line voltage. The winch rope is NOT considered insulating.
- Inspect the winch rope before each use for wear, cuts, or other damage. Replace the rope at the first sign of damage or deterioration.
- Avoid shock loads.
- Improper use of the jib and winch may result in death or serious injury.
- Refer to the Operator's Manual for more information on the safe and proper use of the jib and winch.

11446-1

7393-2 PER ANSI Z535.4-1991

**INSULATED SECTION**

7393-2

7393-1 PER ANSI Z535.4-1991

**INSULATED SECTION**

7393-1

14706-1 PER ANSI Z535.4-1991

**⚠ DANGER**

VISUALLY VERIFY THAT THE QUICK PIN RETAINERS AND BOTH LOCK PINS ARE ENGAGED PROPERLY BEFORE OPERATING THE LIFT OR LIFTING A LOAD.

QUICK PIN RETAINERS  
LOCK PINS  
QUICK PIN

14706-1

5098-1 PER ANSI Z535.4-1991

**INSULATED SECTION**

5098-1

7584-1 PER ANSI Z535.4-1991

**⚠ CAUTION**

REFER TO SERVICE MANUAL BEFORE ADJUSTING SYSTEM RELIEF VALVE

7584-1

33656-3 PER ANSI Z535.4-1991

**⚠ DANGER**

FAILURE TO OBEY THE FOLLOWING WILL RESULT IN DEATH OR SERIOUS INJURY

AERIAL DEVICE MUST BE LEVELED WITHIN 2° OF HORIZONTAL PRIOR TO AERIAL OPERATION. OUTRIGGERS MUST BE DEPLOYED FOR STABILITY.

33656-3

12340-1 PER ANSI Z535.4-1991

**⚠ DANGER**

Electrocution / Fire Hazard

Contact with energized lines while using conductive tool hoses will result in death or serious injury.

Use only orange, non-conductive hose for tools, in the platform area and insulated sections.

Read and understand operator's manual.

12340-1

15732-1 PER ANSI Z535.4-1991

**⚠ CAUTION**

SLOWLY LOOSEN BLEED PORT PLUG TO LOWER BOOM. OIL WILL DISCHARGE FROM PLUG. DO NOT REMOVE PLUG! LOOSEN "BASE" PORT PLUG TO RETRACT. LOOSEN "ROD" PORT PLUG TO EXTEND. TIGHTEN PLUG AS DESCRIBED IN SERVICE MANUAL PRIOR TO OPERATION.

15732-1

|   |   |  |  |  |
|---|---|--|--|--|
| <b>⚠ DANGER</b>   |   |  |  |  |
| <p>The total load in this platform must not exceed the rated capacity including operator, tools, liner, and materials. Excess load may cause a fall resulting in death or serious injury.</p> | <b>RATED PLATFORM CAPACITY</b>  |  |  |  |
|   | <table border="1"> <tr> <td></td> <td><b>AAA LBS (AAA kg) with jib and winch removed</b></td> </tr> <tr> <td></td> <td><b>BBB LBS (BBB kg) with jib and winch installed</b></td> </tr> </table> |  | <b>AAA LBS (AAA kg) with jib and winch removed</b> |  |
|   | <b>AAA LBS (AAA kg) with jib and winch removed</b>  |  |  |  |
|   | <b>BBB LBS (BBB kg) with jib and winch installed</b>  |  |  |  |
| <small>PER ANSI Z35.4-1991 29818-X</small>  |   |  |  |  |

A safe attitude is very important to you, the operator. Practice anticipating accidents and operating hazards. Then determine a corrective course of action to respond to the situation. This habit will sharpen your safety awareness, quicken your reaction time, and prevent many accidents.

**THINK SAFETY**

The following sketches illustrate some of the unsafe situations that might occur during the use or operation of the Versalift. Some of these safety problems are very basic and as a result are often taken for granted.

|  |  |
|--|--|
| <b>⚠ DANGER</b>  |  |
| <b>RATED JIB CAPACITY</b>  |  |
| <ul style="list-style-type: none"> <li>- Do not exceed boom material handling capacity plus unused platform capacity.</li> <li>- Do not exceed jib pole capacity.</li> <li>- Excess load may cause a fall resulting in death or serious injury.</li> </ul> | <p>Jib pole capacity decal<br/>Boom material handling capacity decal</p> |
| <small>21860-1 PER ANSI Z35.4-1991</small>   |  |

|  |   |
|--|---|
| <b>⚠ DANGER</b>  |   |
| <b>RATED JIB CAPACITY</b>  |   |
| <ul style="list-style-type: none"> <li>- Do not exceed boom material handling capacity plus unused platform capacity.</li> <li>- Do not exceed jib pole capacity.</li> <li>- Lower boom must be above 30° for jib loads greater than 100 lbs (45 kg).</li> <li>- Excess load may cause a fall resulting in death or serious injury.</li> </ul> | <p>Jib pole capacity decal<br/>Boom material handling capacity decal<br/>Lower boom angle indicator</p> |
| <small>21860-2 PER ANSI Z35.4-1991</small>   |   |

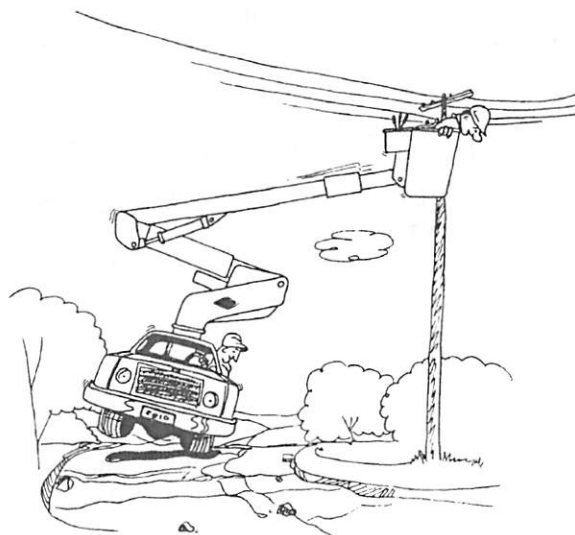

Always engage the outriggers, and maintain the correct tire pressure to increase vehicle stability.

|   |  |
|---|--|
| <b>⚠ DANGER</b>   |  |
| <b>ELECTROCUTION HAZARD</b>   |  |
| FAILURE TO OBEY THE FOLLOWING WILL RESULT IN DEATH OR SERIOUS INJURY  |  |
| <p>THE UPPER CONTROLS DO NOT PROVIDE PROTECTION IN THE EVENT OF ELECTRICAL CONTACT AND ARE NOT A SUBSTITUTE FOR MINIMUM APPROACH DISTANCES, COVER-UPS, RUBBER GLOVES AND OTHER PERSONAL PROTECTIVE EQUIPMENT.</p> |  |
| <small>33974-1 PER ANSI Z35.4-1991</small>  |  |

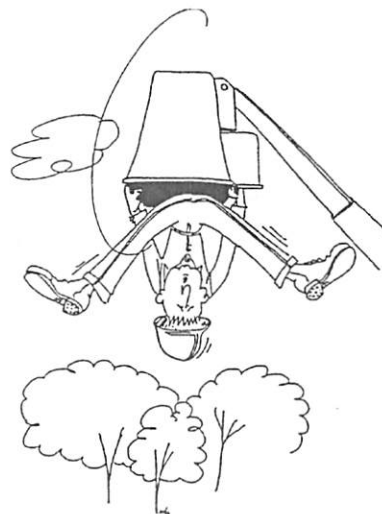

Always wear a personnel restraint system attached to the lanyard anchor.



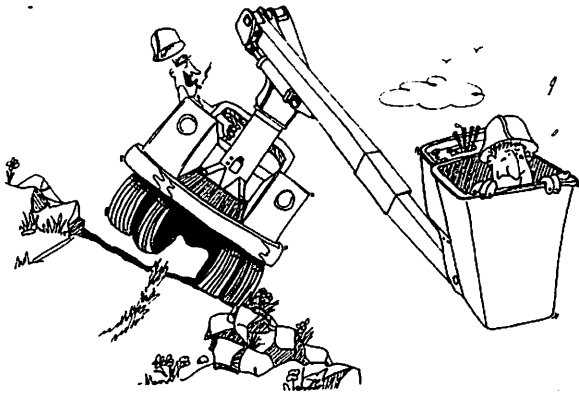

Don't park the truck on a hill unless absolutely necessary. When the truck is parked on a slope, take the special precautions defined in Chapter 4, "Operation".

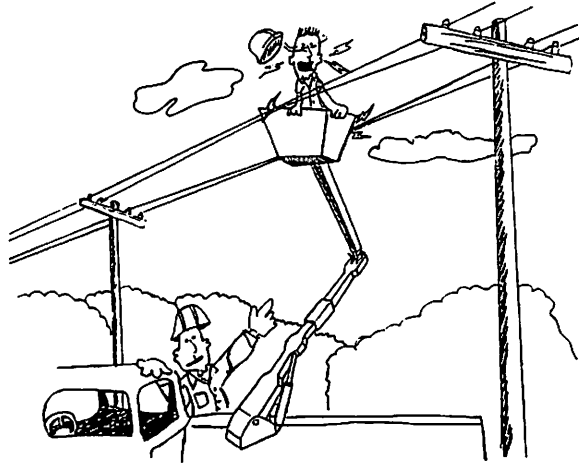

Maintain safe clearances from electrical power lines and apparatus. The aerial lift does not provide protection from contact or proximity to two or more electrically charged conductors.

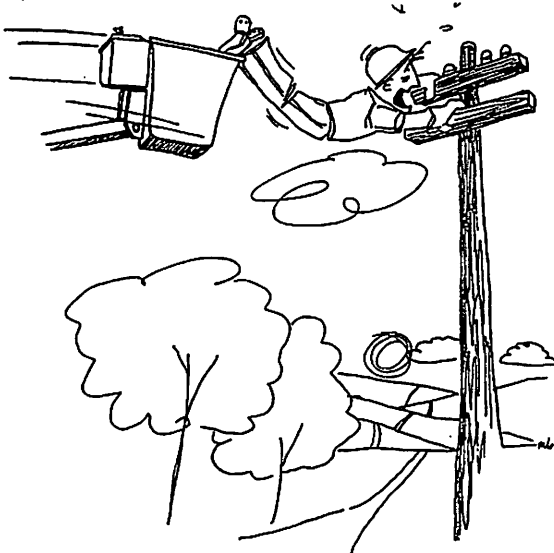

Remember to set the parking brake and chock the truck's wheels.

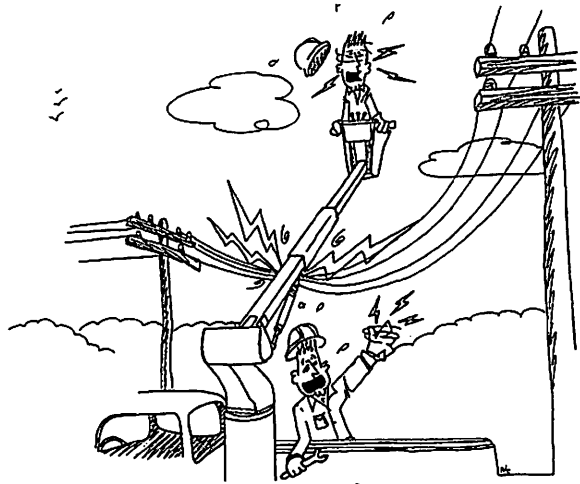

Never allow anyone on the ground to touch the unit when the lift is being used to work on or near electrical lines.

RESPONSIBILITIES / SAFETY

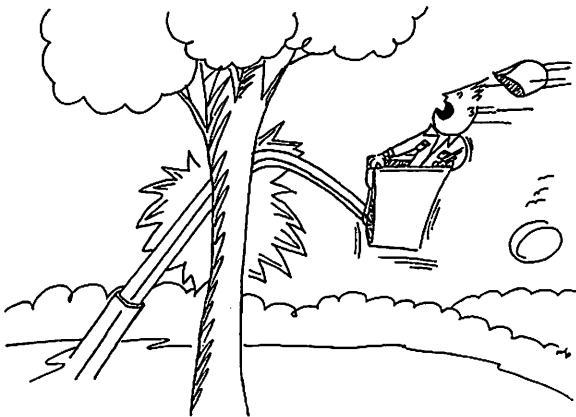

Watch the booms to make sure they clear the truck and other obstructions.

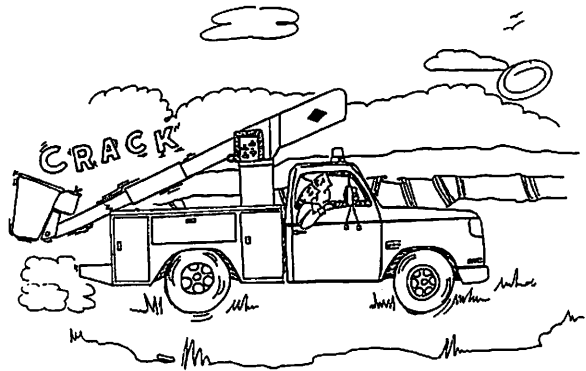

Stow the booms securely before moving the truck.



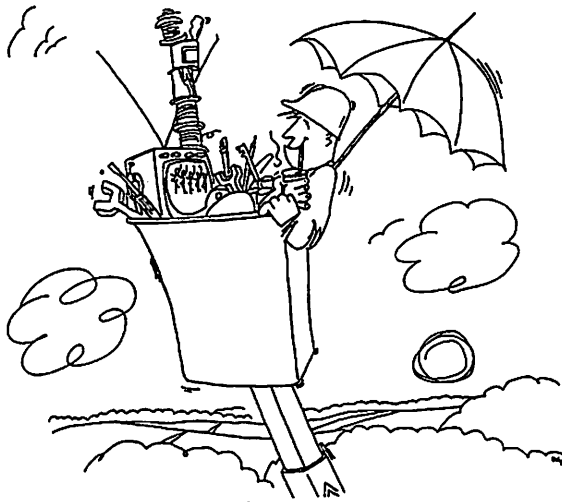

Whenever tools or equipment are included with the operator in the platform the combined weight must not exceed the rated load capacity.



Don't climb out of a raised platform onto poles, etc.

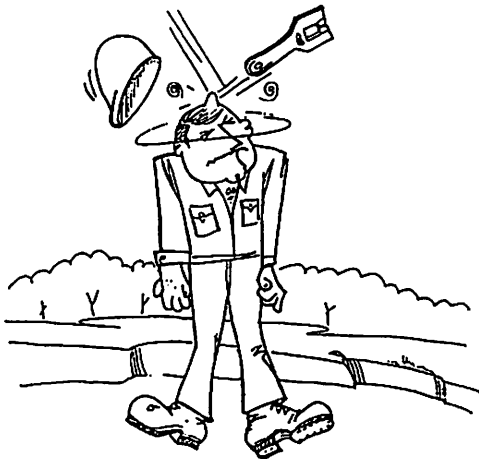

Avoid dropping tools. Use a hand line to raise or lower tools to/from the platform.

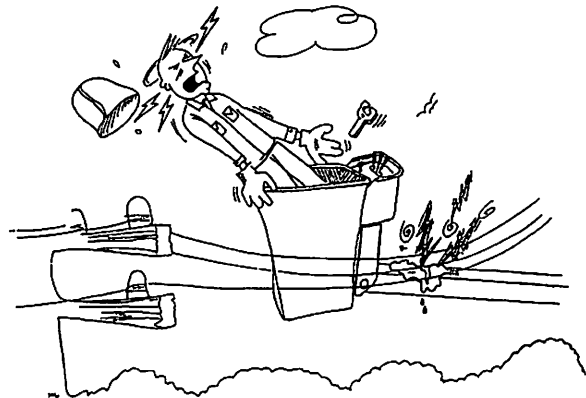

Keep the fiberglass booms clean and dry. Foreign substances on the booms conduct electricity.

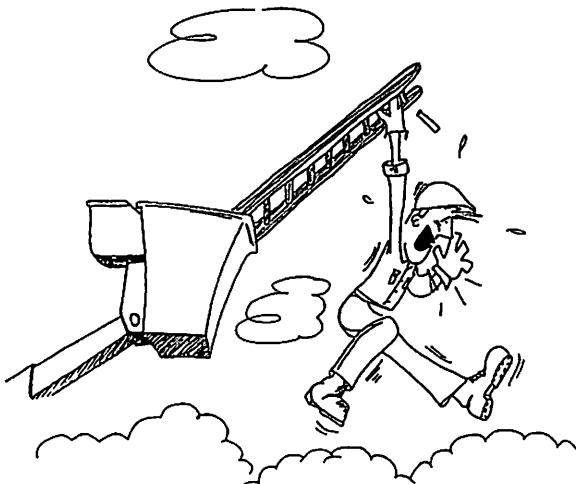

Stand only on the platform floor.

## What Is Insulated and What Is Not Insulated Articulated/Telescopic and Articulated Models

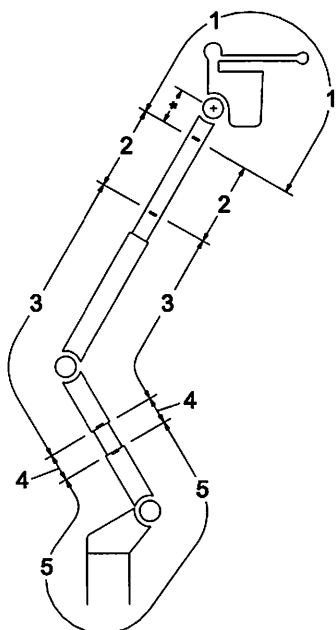

Area 1 - Boom Tip Area - NOT INSULATED

Area 2 - Upper Boom Insulating Section

Area 3 - Intermediate Structure - NOT INSULATED

Area 4 - Lower Boom Insulating Section

Area 5 - Lower Structure - NOT INSULATED

**Area 1, Boom Tip Area** – The boom tip area does not provide insulation. This area includes everything past the insulated section decal\* on the upper boom. This includes the upper end of the boom, platform support, platform(s), controls, and the jib/winch/rope (when so equipped).

All components at the boom tip area must be considered to be conductive and electrically connected, even with an insulated liner in place. Any contact with a ground and a phase or between two phase conductors will create a hazard of serious personal injury or death. Contact between an energized conductor and any part of the boom tip will energize the entire boom tip.

When working near an energized conductor, ground conductor, or other grounded objects, the operator must use the proper safety equipment (such as rubber gloves, covers, hot sticks, etc.), maintain safe approach distances, and follow company work practices.

**Area 2, Upper Boom Insulation Section** – This section provides insulation\*\* between the boom tip area and earth ground when clean and properly maintained. On some configurations, it is necessary to extend the boom until the insulated section decal is visible.

**Area 3, Intermediate Structure** – This section does not provide insulation. This area includes the lower steel portion of the upper boom, knuckle, and the

steel upper portion of the lower boom and compensation link (when applicable).

**Area 4, Lower Boom Insulating Section** – (When so equipped) This section provides insulation\*\* between the intermediate structure (Area 3) and the vehicle when clean and properly maintained.

**Area 5, Lower Structure** – This area does not provide insulation. This area includes the steel lower portion of the lower boom and compensation link (when applicable), turret, lower controls, pedestal, and the vehicle.

\* On VST and T-Series models not supplied with an upper insulated section decal, the insulated section begins 11 inches below the center of the platform pivot.

\*\* Insulation properties are defined by ANSI A92.2

RESPONSIBILITIES / SAFETY



## ADDITIONAL SAFETY CONSIDERATIONS

1. Report any unusual occurrence during the operation of the aerial lift that may require repair or adjustment.
2. Keep the work space in the truck bed clean and neat.
3. Avoid parking on soft surfaces. Soft surfaces may suddenly collapse, shift, or sink beneath the truck's weight.
4. There is no insulating value in the fiberglass platform without a platform liner.
5. No attempt should be made to clean, oil, or adjust a machine while the machine is in motion.
6. If an aerial lift has set idle for an extended period (i.e. overnight) or has been recently serviced, cycle the aerial-lift through its full range of motion several times. This procedure will force any trapped air out of the hydraulic system. Do not operate the lift from the platform until this process is completed. Air trapped in the hydraulic oil can cause lift movements to be erratic and unpredictable.
7. Don't operate any part of the unit (platform, booms, outriggers, etc.) outside the work-site barricades into the traffic lanes. Set up adequate cones or barricades to mark the boundaries of the work-site to alert motorists and pedestrians.
8. Only qualified mechanics are authorized to service the aerial lift.
9. The polyester winch rope is not an insulator. Dirt, grease, and moisture (humidity) make the rope conductive.
10. Make a thorough check of the winch rope for abrasive wear, pulled strands, cuts, and other defects daily.
11. Replace the winch rope at the first sign of damage or deterioration. Use only non-conductive rope of the size and type specified.
12. Avoid shock loads. A shock load is caused by jerking a line with a load or a sudden change in rope tension from a light load to a heavy load.
13. Do not contact energized conductors with the winch line. Contacting the load line with an energized conductor could create a complete path for electricity when the rope is extended to the ground. This could cause death or serious injury.
14. Avoid using the winch line to wrap or tie an object for lifting. The hook attached to the end of the winch line can damage or cut the rope. A sling or lifting strap is recommended for this purpose.
15. Do not stand in line with a rope under tension. If the rope should fail the recoil could cause serious injury to personnel.
16. Inspect the jib-pole assembly to make sure the various lock pins are secure.
17. Make sure the winch-rope coils are spooling evenly to avoid clogging the winch or producing shock loads when lifting a load.
18. Avoid contacting a spray or mist produced by a high pressure hydraulic leak. This spray or mist can puncture or become embedded beneath the skin or contaminate the eyes. These conditions requires immediate medical attention.
19. Hydraulic oil is flammable. Avoid any contact between hydraulic oil and sources of high heat or open flames.
20. Bodily contact with hot hydraulic oil can cause serious burns which require immediate medical attention.

# SPECIFICATIONS

## GENERAL SPECIFICATIONS – VST-36/40/47/52-I

*Note: Specifications on units may vary or change without prior notifications due to option selections.*

This section includes a brief description of each of the major (standard) components.

**PLATFORM** - The closed fiberglass platform is 24 in. x 24 in. x 42 in. deep (.61 m x .61 m x 1.07 m) with an inside and outside step for easy access.

*Maximum rated platform capacity* for all models is 600 lbs (272 kg) without jib/winch and 500 lbs (227 kg) with jib/winch.

The actual platform capacity may be reduced depending on the chassis and mounting configuration. See "Vehicle Specifications" for the actual platform capacity of a particular installation.

**PERSONNEL RESTRAINT SYSTEM** - A safety belt or harness and a lanyard are required and can be supplied by Time Manufacturing Company at an additional cost. Consult applicable work practices and regulations to choose between a safety belt and a harness. The anchor for the lanyard is attached to the platform support.

**INDIVIDUAL LOWER CONTROLS** - Individual full-pressure controls at the turret actuate all boom functions. The lower control station is equipped with a selector valve to override the upper controls.

**SINGLE STICK UPPER CONTROL** - The full-pressure single-stick upper control includes a safety trigger to prevent inadvertent operation. The lift movements correspond with control handle movements. An emergency stop and a tool selector control are located at the upper controls.

**HYDRAULIC PLATFORM ROTATION** - A hydraulic rotary actuator, operated by a control lever, rotates the platform 180° from one side of the boom, to the end-hung position, and to the other side of the boom.

**HYDRAULIC PLATFORM LEVELING** - A master and slave cylinder controls platform leveling. The leveling system can be operated from the upper or lower controls to adjust platform leveling, tilt the platform for clean out, or to ease the removal of an injured operator.

**OUTER/INNER BOOM ASSEMBLY** - The outer/inner boom assembly includes an outer boom, telescopic

inner boom, extension system, and hose assemblies. The outer boom consists of an 8 in. x 10 in. (203 mm x 254 mm) steel section, with a 9 in. x 11 in. (229 mm x 279 mm) fiberglass Electroguard section (N/A on VST-52). The 6-7/8 in. x 8-7/8 in. (165 mm x 216 mm) rectangular fiberglass inner boom is housed within the outer boom. The extension system consists of an extension cylinder, holding valves, and a hose carrier housed inside the boom. The hoses routed through the outer/inner boom assembly are non-conductive and fully contained within the boom assembly.

A double acting cylinder with two integral holding valves articulates the outer/inner boom assembly. A boom support cradle and a boom tie down strap are included.

**LOWER BOOM WITH CHASSIS INSULATING SYSTEM** - Each end of a high strength fiberglass insert (chassis insulating system) is installed inside a rectangular 8 in. x 10 in. (203 mm x 254 mm) high strength steel section. The steel and fiberglass sections are bonded with pressure-injected epoxy to fill any voids. A double acting cylinder, with two integral holding valves, articulates the lower boom. The lower boom and compensation link form a parallelogram linkage to maintain the knuckle at a constant angle to the turret.

**CYLINDERS** - Both the upper and lower cylinders are a threaded head-cap design. Both are equipped with two integral holding valves that prevent down creep and to lock the booms in position in the event of hose failure.

**TURRET** - The turret wings are designed for strength and rigidity. A bearing cover seals out moisture and prevents foreign materials from obstructing the turret rotation. The turret plate is machined to provide a flat surface to support the rotation bearing.

**CONTINUOUS ROTATION** - Unrestricted rotation is accomplished by a hydraulically driven worm and spur gear with a shear-ball rotation bearing. The critical bolts holding the lift to the rotation bearing and the rotation bearing to the pedestal are grade 8 hex head capscrews. These critical bolts are torque seal marked to provide a quick means of detecting any turning of the bolt upon inspection. An eccentric ring is used for gearbox backlash adjustment.

**LUBRICATION** - Non-lube bearings are used at most points of motion. Only the rotation bearing requires periodic lubrication.

**PEDESTAL** - The pedestal is tubular with a reinforced



mounting plate. The top plate of the pedestal is 1-1/4 in. (32 mm) thick and machined flat to support the rotation bearing.

**HYDRAULIC OIL RESERVOIR** - A 17 gallon (64.4 l) hydraulic oil reservoir is built integral to the pedestal. Two sight gauges allow quick hydraulic fluid level checks.

**HYDRAULIC SYSTEM** - The open-center hydraulic system operates at 3000 psi (210 kg/cm<sup>2</sup>) at 6 gpm (22.7 lpm). A 10-micron return-line filter, mounted above the hydraulic oil level and inside the pedestal, can be easily changed without draining the reservoir. The 100 mesh (149 micron) suction strainer in the reservoir can be removed for cleaning. A gate valve, located below the reservoir, prevents oil loss when the pump is serviced. A magnetic drain plug attracts metal particles from the oil.

**PAINT** - The complete unit is primed and painted prior to assembly. The standard color is white urethane.

**HOSES AND FITTINGS** - The hoses routed through the booms are high pressure and non-conductive with swaged hose end fittings. Retainers separate the hoses inside the booms to prevent chafing and nylon sleeves are installed over hoses at points of movement. Reusable fittings can be installed if a hose is damaged.

**ENGINE START / STOP** - The start/stop circuit has been designed so the lift cannot be operated unless the truck ignition switch is in the "RUN" position and the master control is activated. This feature makes it difficult for unauthorized individuals to operate the lift when the truck is locked. An air cylinder at the upper controls and a toggle switch at the pedestal energize this system.

**HYDRAULIC TOOL CIRCUIT AT THE PLATFORM** - This system is intended for open center hydraulic tools. The tool circuit provides 6 gpm (22.7 lpm). A pressure reducing valve in the tool circuit limits the tool pressure. The valve can be adjusted from 1000 to 2500 psi (70 to 175 kg/cm<sup>2</sup>).

**LINE-LIFTING SOCKET** - Built as part of the platform support structure, is a vertical line-lifting socket for 3 in. (76 mm) diameter line-lifting attachments. The socket is automatically leveled with the platform without any manual adjustments.

**ELECTRICAL INSULATION SPECIFICATIONS** - The outer/inner boom assembly is tested and certified for electrical work at 46 KV and below in

accordance with ANSI A92.2 requirements. Aerial devices may be designed and configured for gloving work and tool methods at 46KV and below. The outer/inner boom assembly is fully insulated even in a retracted position. The chassis insulating system (lower boom insert) is also tested according to ANSI A92.2.

**SLOPE INDICATORS** - Slope indicators are required on Versalift units and supplied by Time Manufacturing Co. Slope indicators shall be installed to indicate the level of the rotation bearing relative to the ground.

**OUTRIGGER / BOOM INTERLOCK SYSTEM** - The outrigger/boom interlock system prevents lift operation until the outriggers contact the ground and outrigger retraction before the aerial lift is properly stored.

**MANUALS** - Two Operator's Manuals, two Service Manuals, one Manual of Responsibilities, and one EMI Safety Manual are included with each aerial lift.

### OPTION SPECIFICATIONS – VST-36/40/47/52-I

Below is a brief description of some of the available options for the aerial lift.

**OUTRIGGERS** - The modified A-frame outriggers are equipped with pilot operated check valves, internal thermal relief valves, pivot feet, and separate controls. Outrigger dimensions vary with chassis application. For a 31 in. (0.79 m) frame height, the outriggers furnish 122 in. (3.1 m) of spread, 8 in. (203 mm) of penetration, and 18 in. (457 mm) of ground clearance. For a 37-1/4 in. (0.95 m) frame height, the outriggers furnish 125-3/8 in. (3.2 m) of spread, 8 in. (203 mm) of penetration, and 18 in. (457 mm) of ground clearance.

**INDEPENDENT OUTRIGGERS** – Narrow angle modified A-frame outriggers are shear-plate mounted to the frame and are equipped with pilot operated check valves, internal thermal relief valves, pivot feet, and separate controls. Outrigger dimensions vary with chassis application. For a 37-1/4 in. (0.95 m) frame height, the outriggers furnish 101-3/4 in. (2.6 m) of spread, 7-3/4 in. (197 mm) of penetration, and 15-3/4 in. (400 mm) of ground clearance.

**TORSION BAR** – (VST-36/40 only) An over-frame or under-frame torsion bar for the rear axle adds stability to the vehicle and is available as an option. Ballast may be required with the use of a torsion bar. A front axle under-frame torsion bar is also available and can

be used in conjunction with the rear torsion bar to reduce the amount of ballast needed.

**BACKUP PUMP** - An auxiliary hydraulic pump designed to bring the booms down in case the main hydraulic source fails. The back up hydraulic pump is driven by a DC motor, which is powered by the truck-engine battery. The system is connected in parallel with the main pump and is designed for non-continuous operation. An air cylinder at the upper controls and a toggle switch at the pedestal are used to energize the system.

**SECOND SET OF TOOL POWER PORTS** - A second set of tool power ports are installed at the platform to accommodate a second open center tool.

**EXTRA CONTROL CIRCUIT** - Consists of an additional air cylinder at the platform, toggle switch at the pedestal, pressure switch in the turret and airline to the platform. An additional pass in the collector ring is required for each control circuit.

**MANUAL THROTTLE CONTROL** - Gives the operator a choice of economical engine idle speeds or faster engine speeds with faster lift movements when required. The manual throttle control is designed to operate only when the truck engine is running and the master control is activated. An air cylinder at the platform or a toggle switch at the pedestal can be used to energize the manual throttle control.

**UNITROL 4-FUNCTION CONTROL** - The 4-Axis controller option is a full pressure control. Located at the platform, the 4-axis control consists of a single handle control which, through linkage, actuates the interlock section and four individual boom function valves.

**TRUGUARD** - This advanced upper controls isolation system provides 4" of electrical isolation from the entire upper controls, including the control dash panel. This system also includes a protective shield which helps prevent environmental and work related contaminants from making direct contact with the isolating surfaces.

**THE UPPER CONTROLS DO NOT PROVIDE PROTECTION IN THE EVENT OF ELECTRICAL CONTACT AND ARE NOT A SUBSTITUTE FOR MINIMUM APPROACH DISTANCES, COVER-UPS, RUBBER GLOVES AND OTHER PERSONAL PROTECTIVE EQUIPMENT.**

**CATEGORY D DIELECTRIC TESTING AND CERTIFICATION** - Testing and certification for ANSI A92.2 Category D are available. These aerial devices which are designed and manufactured for work in which the insulating system is not considered as primary insulation, but secondary. These aerial devices are NOT designed for gloving work methods. They are rated at voltages of 46kv.

**REMOTE LOWER CONTROL** - This option allows remote operation of the aerial device. The remote lower controls override the upper controls and are housed in a weather-resistant hand held box or metal box.

**PLATFORM VARIATIONS:**  
 24 in. x 24 in. (0.61 m x 0.61 m) Fiberglass Platform (Standard)  
 24 in. x 30 in. (0.61 m x 0.76 m) Fiberglass Platform  
 24 in. x 42 in. (0.61 m x 1.07 m) Fiberglass Platform

24 in. x 48 in. (0.61 m x 1.22 m) Fiberglass Platform

36 in. x 60 in. (0.91 m x 1.52 m) Aluminum Walk-In Platform (Reduces maximum platform capacity by 100 lbs.) This option requires Category D rating.

40 in. x 64 in. (1.02 m x 1.55 m) Aluminum Walk-In Platform (Reduces maximum platform capacity by 100 lbs.) This option requires Category D rating.

**PLATFORM COVER** - Vinyl covers are available for the platforms.

**PLATFORM LINER** - Platform liners are available for each of the platforms.

**LIFTING EYE** - A lifting eye attachment near the end of the outer boom has a 1000 lbs. (455 kg) maximum capacity. (Not available on the VST-36-I)

**PEDESTAL HEIGHT VARIATIONS** - Various height pedestals are available to accommodate different cab heights and mounting locations. See the detailed Dimensional Specifications below for the available and standard pedestal heights of each model.

**MANUAL JIB AND WINCH** - The material handling jib and winch consists of a winch and a jib pole that are automatically leveled with the platform. Up to 1000 lbs. (454 kg) material handling capacity can be provided at elevated boom angles. The winch is hydraulically powered through a self-locking worm gear drive, so a load-holding brake is not required. The winch provides line speeds of 15 to 30 ft. per minute (5 to 9 m per min.). Eighty feet (24 m) of 1/2-in. (13 mm) diameter polyester rope with a clevis hook



is provided.

The angle of the jib pole is manually adjusted; the jib-pole assembly tilts in 10° increments from horizontal to a maximum of 50° above horizontal. The jib-pole assembly also can be rotated to any of the three convenient load-lifting positions to accommodate a load. Those positions are 30° CW, 0°, and 30° CCW from the boom centerline. The jib pole and winch assemblies can be rotated to a stowed position 180° from the end hung position, or they can be easily removed when not needed.

**HYDRAULIC JIB AND WINCH** - The material handling jib and winch consists of a winch and a jib pole that are automatically leveled with the platform. Up to 1000 lbs. (454 kg) material-handling capacity can be provided at elevated boom angles. The winch is hydraulically powered through a self-locking worm gear drive, so a load-holding brake is not required. The winch provides line speeds of 15 to 30 ft. per minute (5 to 9 m per min.). Eighty feet (24 m) of 1/2-in. (13 mm) diameter polyester rope with a clevis hook is provided.

The 4 in. (100 mm) square jib pole hydraulically tilts with 90° of travel relative to the platform, from horizontal to vertical. Since the pole is automatically leveled with the platform, there is a total of 200° of jib pole articulation relative to the upper boom. The jib pole also hydraulically extends and retracts, providing 16-in. (400-mm) travel, from 44 in. to 60 in. (1.1 m to 1.5 m). The jib-pole assembly also can be rotated to any of three convenient load-lifting positions to accommodate a load. The jib pole and winch assemblies can be rotated to a stowed position 180° from the end-hung position, or they can be easily removed when not needed.

**ARTICULATED JIB** – Jib and winch consisting of a winch, two piece jib pole assembly, and articulating arm. Up to 1000 lbs material handling can be provided depending on boom and jib positions. The winch is hydraulically powered by a self-locking worm gear drive and is rated at 1000 lbs full drum. The winch provides an average line speed of approximately 20 FPM (6.1 m/minute).

The 3" diameter round inner jib pole is dielectrically tested and can be manually pinned in 5 different length positions, for a total of 22" length adjustment. The 4" diameter round outer jib pole is manufactured from FRP but is not dielectrically tested. The jib pole assembly is automatically leveled with the platform and can be hydraulically tilted from -10° to + 86° for a total of 96°.

The jib pole assembly is mounted on an articulating arm. The arm is compensated so the jib pole stays at approximately the same angle relative to the ground as the arm articulates. The arm travels 91°, providing the equivalent to 17.5" horizontal jib pole extension and 20" vertical jib pole extension. The jib and winch assembly can be manually indexed about a vertical axis in one of three different pin positions. This positions the jib up to 30° to either side of the boom, for a total travel of 60°. The jib and winch assembly can be removed without tools when not needed.

**AUTOMATIC BOOM LATCH** – The automatic boom latch is designed to automatically restrain the upper boom in the cradle when stowed and automatically release the boom when the lift is operated. The latch is actuated by a hydraulic cylinder and includes a manual over-ride to open the latch without hydraulic power.

**PLATFORM ELEVATOR (Single Platform Only)** – Hydraulically controlled platform elevator which will raise the platform and control panel 24" at the boom tip. Driven by a telescoping cylinder, the platform elevator can be raised proportionally using the same style control valve used for all boom function. **Note:** This reduces the platform capacity and jib capacity by 100 lbs.

## VST-36-I DIMENSIONAL SPECIFICATIONS

Based on 40 in (1.02 m) Frame Height, all Dimensions Nominal

|  |                    |
|--|--------------------|
| Horizontal Reach .....   | 26 ft 2 in (8.0 m) |
| Maximum Platform Capacity (varies with installation and jib/winch) ..... | 600 lbs. (272 kg)  |
| Jib Capacity (varies with boom position) .....                           | 1000 lbs. (454 kg) |

### With 46.25 in (1.17 m) Tall Pedestal (Standard)

|                                    |                      |
|------------------------------------|----------------------|
| Height to Bottom of Platform ..... | 36 ft 4 in (11.1 m)  |
| Working Height .....               | 41 ft 4 in (12.6 m)  |
| Stowed Travel Height .....         | 10 ft 6 in (3.2 m)   |
| Weight of Lift .....               | 3,200 lbs. (1450 kg) |

### With 52.25 in (1.33 m) Tall Pedestal (6 in taller)

|                                    |                      |
|------------------------------------|----------------------|
| Height to Bottom of Platform ..... | 36 ft 10 in (11.2 m) |
| Working Height .....               | 41 ft 10 in (12.8 m) |
| Stowed Travel Height .....         | 11 ft 0 in (3.4 m)   |
| Weight of Lift .....               | 3,220 lbs. (1460 kg) |

### With 58.25 in (1.48 m) Tall Pedestal (12 in taller)

|                                    |                      |
|------------------------------------|----------------------|
| Height to Bottom of Platform ..... | 37 ft 4 in (11.4 m)  |
| Working Height .....               | 42 ft 4 in (12.9 m)  |
| Stowed Travel Height .....         | 11 ft 6 in (3.5 m)   |
| Weight of Lift .....               | 3,240 lbs. (1470 kg) |

### With 64.25 in (1.63 m) Tall Pedestal (18 in taller)

|                                    |                      |
|------------------------------------|----------------------|
| Height to Bottom of Platform ..... | 37 ft 10 in (11.5 m) |
| Working Height .....               | 42 ft 10 in (13.1 m) |
| Stowed Travel Height .....         | 12 ft (3.7 m)        |
| Weight of Lift .....               | 3,260 lbs. (1480 kg) |

### Hydraulic System

|                          |                                      |
|--------------------------|--------------------------------------|
| Operating Pressure ..... | 3000 psi (210 kg/cm <sup>2</sup> )   |
| Flow Rate .....          | 6 gpm (22.7 lpm)                     |
| Filtration .....         | 10 micron Return<br>100 mesh Suction |
| System Type .....        | Open Center                          |
| Power Source .....       | PTO Pump                             |

### Boom Action

|                               |                  |
|-------------------------------|------------------|
| Outer/Inner Boom Travel ..... | -25° to +85°     |
| Lower Boom Travel .....       | 0° to +87°       |
| Inner Boom Extension .....    | 79 in (2.0 m)    |
| Rotation .....                | 360° Continuous. |

### Insulation Gap

|                                  |                |
|----------------------------------|----------------|
| Upper Boom Fully Retracted ..... | 46 in (1.2 m)  |
| Lower Boom .....                 | 12 in (305 mm) |

Ambient Temperature Range for Structural Integrity ..... -40°F (-40°C) to 125°F (52°C)

SPECIFICATIONS



## VST-40-I DIMENSIONAL SPECIFICATIONS

Based on 40 in (1.02 m) Frame Height, all Dimensions Nominal

|  |                    |
|--|--------------------|
| Horizontal Reach .....   | 30 ft 2 in (9.2 m) |
| Maximum Platform Capacity (varies with installation and jib/winch) ..... | 600 lbs. (272 kg)  |
| Jib Capacity (varies with boom position) .....                           | 1000 lbs. (454 kg) |

### With 46.25 in (1.17 m) Tall Pedestal (Standard)

|                                    |                      |
|------------------------------------|----------------------|
| Height to Bottom of Platform ..... | 40 ft 4 in (12.3 m)  |
| Working Height .....               | 45 ft 4 in (13.8 m)  |
| Stowed Travel Height .....         | 10 ft 6 in (3.2 m)   |
| Weight of Lift .....               | 3,300 lbs. (1495 kg) |

### With 52.25 in (1.33 m) Tall Pedestal (6 in taller)

|                                    |                      |
|------------------------------------|----------------------|
| Height to Bottom of Platform ..... | 40 ft 10 in (12.4 m) |
| Working Height .....               | 45 ft 10 in (14.0 m) |
| Stowed Travel Height .....         | 11 ft 0 in (3.4 m)   |
| Weight of Lift .....               | 3,320 lbs. (1505 kg) |

### With 58.25 in (1.48 m) Tall Pedestal (12 in taller)

|                                    |                      |
|------------------------------------|----------------------|
| Height to Bottom of Platform ..... | 41 ft 4 in (12.6 m)  |
| Working Height .....               | 46 ft 4 in (14.1 m)  |
| Stowed Travel Height .....         | 11 ft 6 in (3.5 m)   |
| Weight of Lift .....               | 3,340 lbs. (1515 kg) |

### With 64.25 in (1.63 m) Tall Pedestal (18 in taller)

|                                    |                      |
|------------------------------------|----------------------|
| Height to Bottom of Platform ..... | 41 ft 10 in (12.8 m) |
| Working Height .....               | 46 ft 10 in (14.3 m) |
| Stowed Travel Height .....         | 12 ft (3.7 m)        |
| Weight of Lift .....               | 3,360 lbs. (1525 kg) |

### Hydraulic System

|                          |                                      |
|--------------------------|--------------------------------------|
| Operating Pressure ..... | 3000 psi (210 kg/cm <sup>2</sup> )   |
| Flow Rate .....          | 6 gpm (22.7 lpm)                     |
| Filtration .....         | 10 micron Return<br>100 mesh Suction |
| System Type .....        | Open Center                          |
| Power Source .....       | PTO Pump                             |

### Boom Action

|                               |                  |
|-------------------------------|------------------|
| Outer/Inner Boom Travel ..... | -25° to +85°     |
| Lower Boom Travel .....       | 0° to +87°       |
| Inner Boom Extension .....    | 103 in (2.6 m)   |
| Rotation .....                | 360° Continuous. |

### Insulation Gap

|                                  |                |
|----------------------------------|----------------|
| Upper Boom Fully Retracted ..... | 46 in (1.2 m)  |
| Lower Boom .....                 | 12 in (305 mm) |

Ambient Temperature Range for Structural Integrity ..... -40°F (-40°C) to 125°F (52°C)

SPECIFICATIONS



## VST-47-I DIMENSIONAL SPECIFICATIONS

Based on 40 in (1.02 m) Frame Height, all Dimensions Nominal

|  |                    |
|--|--------------------|
| Horizontal Reach .....   | 30 ft 9 in (9.4 m) |
| Maximum Platform Capacity (varies with installation and jib/winch) ..... | 600 lbs. (272 kg)  |
| Jib Capacity (varies with boom position) .....                           | 1000 lbs. (454 kg) |

### With 46.25 in (1.17 m) Tall Pedestal (6 in shorter)

|                                    |                      |
|------------------------------------|----------------------|
| Height to Bottom of Platform ..... | 46 ft 4 in (14.1 m)  |
| Working Height .....               | 51 ft 4 in (15.6 m)  |
| Stowed Travel Height .....         | 10 ft 6 in (3.2 m)   |
| Weight of Lift .....               | 3,580 lbs. (1620 kg) |

### With 52.25 in (1.33 m) Tall Pedestal (Standard)

|                                    |                      |
|------------------------------------|----------------------|
| Height to Bottom of Platform ..... | 46 ft 10 in (14.3 m) |
| Working Height .....               | 51 ft 10 in (15.8 m) |
| Stowed Travel Height .....         | 11 ft 0 in (3.4 m)   |
| Weight of Lift .....               | 3,600 lbs. (1630 kg) |

### With 58.25 in (1.48 m) Tall Pedestal (6 in taller)

|                                    |                      |
|------------------------------------|----------------------|
| Height to Bottom of Platform ..... | 47 ft 4 in (14.4 m)  |
| Working Height .....               | 52 ft 4 in (16.0 m)  |
| Stowed Travel Height .....         | 11 ft 6 in (3.5 m)   |
| Weight of Lift .....               | 3,620 lbs. (1640 kg) |

### With 64.25 in (1.63 m) Tall Pedestal (12 in taller)

|                                    |                      |
|------------------------------------|----------------------|
| Height to Bottom of Platform ..... | 47 ft 10 in (14.6 m) |
| Working Height .....               | 52 ft 10 in (16.1 m) |
| Stowed Travel Height .....         | 12 ft (3.7 m)        |
| Weight of Lift .....               | 3,640 lbs. (1650 kg) |

### Hydraulic System

|                          |                                      |
|--------------------------|--------------------------------------|
| Operating Pressure ..... | 3000 psi (210 kg/cm <sup>2</sup> )   |
| Flow Rate .....          | 6 gpm (22.7 lpm)                     |
| Filtration .....         | 10 micron Return<br>100 mesh Suction |
| System Type .....        | Open Center                          |
| Power Source .....       | PTO Pump                             |

### Boom Action

|                               |                  |
|-------------------------------|------------------|
| Outer/Inner Boom Travel ..... | -25° to +85°     |
| Lower Boom Travel .....       | 0° to +84°       |
| Inner Boom Extension .....    | 103 in (2.6 m)   |
| Rotation .....                | 360° Continuous. |

### Insulation Gap

|                                      |                |
|--------------------------------------|----------------|
| Upper Boom Fully Retracted .....     | 52 in (1.3 m)  |
| Upper Boom Extended 12+ Inches ..... | 64 in (1.6 m)  |
| Lower Boom .....                     | 12 in (305 mm) |

Ambient Temperature Range for Structural Integrity ..... -40°F (-40°C) to 125°F (52°C)

## VST-52-I DIMENSIONAL SPECIFICATIONS

Based on 40 in (1.02 m) Frame Height, all Dimensions Nominal

|  |                    |
|--|--------------------|
| Horizontal Reach .....   | 30 ft 4 in (9.2 m) |
| Maximum Platform Capacity (varies with installation and jib/winch) ..... | 600 lbs. (272 kg)  |
| Jib Capacity (varies with boom position) .....                           | 1000 lbs. (454 kg) |

### With 46.25 in (1.17 m) Tall Pedestal (12 in shorter)

|                                    |                      |
|------------------------------------|----------------------|
| Height to Bottom of Platform ..... | 50 ft 6 in (15.4 m)  |
| Working Height .....               | 55 ft 6 in (16.9 m)  |
| Stowed Travel Height .....         | 10 ft 6 in (3.2 m)   |
| Weight of Lift .....               | 3,760 lbs. (1705 kg) |

### With 52.25 in (1.33 m) Tall Pedestal (6 in shorter)

|                                    |                      |
|------------------------------------|----------------------|
| Height to Bottom of Platform ..... | 51 ft (15.5 m)       |
| Working Height .....               | 56 ft (17.1 m)       |
| Stowed Travel Height .....         | 11 ft 0 in (3.4 m)   |
| Weight of Lift .....               | 3,780 lbs. (1715 kg) |

### With 58.25 in (1.48 m) Tall Pedestal (standard)

|                                    |                      |
|------------------------------------|----------------------|
| Height to Bottom of Platform ..... | 51 ft 6 in (15.7 m)  |
| Working Height .....               | 56 ft 6 in (17.2 m)  |
| Stowed Travel Height .....         | 11 ft 6 in (3.5 m)   |
| Weight of Lift .....               | 3,800 lbs. (1725 kg) |

### With 64.25 in (1.63 m) Tall Pedestal (6 in taller)

|                                    |                      |
|------------------------------------|----------------------|
| Height to Bottom of Platform ..... | 52 ft (15.8 m)       |
| Working Height .....               | 57 ft (17.4 m)       |
| Stowed Travel Height .....         | 12 ft (3.7 m)        |
| Weight of Lift .....               | 3,820 lbs. (1730 kg) |

### Hydraulic System

|                          |                                      |
|--------------------------|--------------------------------------|
| Operating Pressure ..... | 3000 psi (210 kg/cm <sup>2</sup> )   |
| Flow Rate .....          | 6 gpm (22.7 lpm)                     |
| Filtration .....         | 10 micron Return<br>100 mesh Suction |
| System Type .....        | Open Center                          |
| Power Source .....       | PTO Pump                             |

### Boom Action

|                               |                  |
|-------------------------------|------------------|
| Outer/Inner Boom Travel ..... | -25° to +85°     |
| Lower Boom Travel .....       | 0° to +84°       |
| Inner Boom Extension .....    | 53 in (1.35 m)   |
| Rotation .....                | 360° Continuous. |

### Insulation Gap

|                                      |                |
|--------------------------------------|----------------|
| Upper Boom Fully Retracted .....     | 52 in (1.3 m)  |
| Upper Boom Extended 12+ Inches ..... | 64 in (1.6 m)  |
| Lower Boom .....                     | 12 in (305 mm) |

Ambient Temperature Range for Structural Integrity ..... -40°F (-40°C) to 125°F (52°C)

SPECIFICATIONS

| REV.  | ERCN NO. | DESCRIPTION   | BY  | CHKD. | APPR. | DATE     |
|-------|----------|---------------|-----|-------|-------|----------|
| 56818 |          | FIRST RELEASE | LBR | D.JH  | SRS   | 12-13-07 |

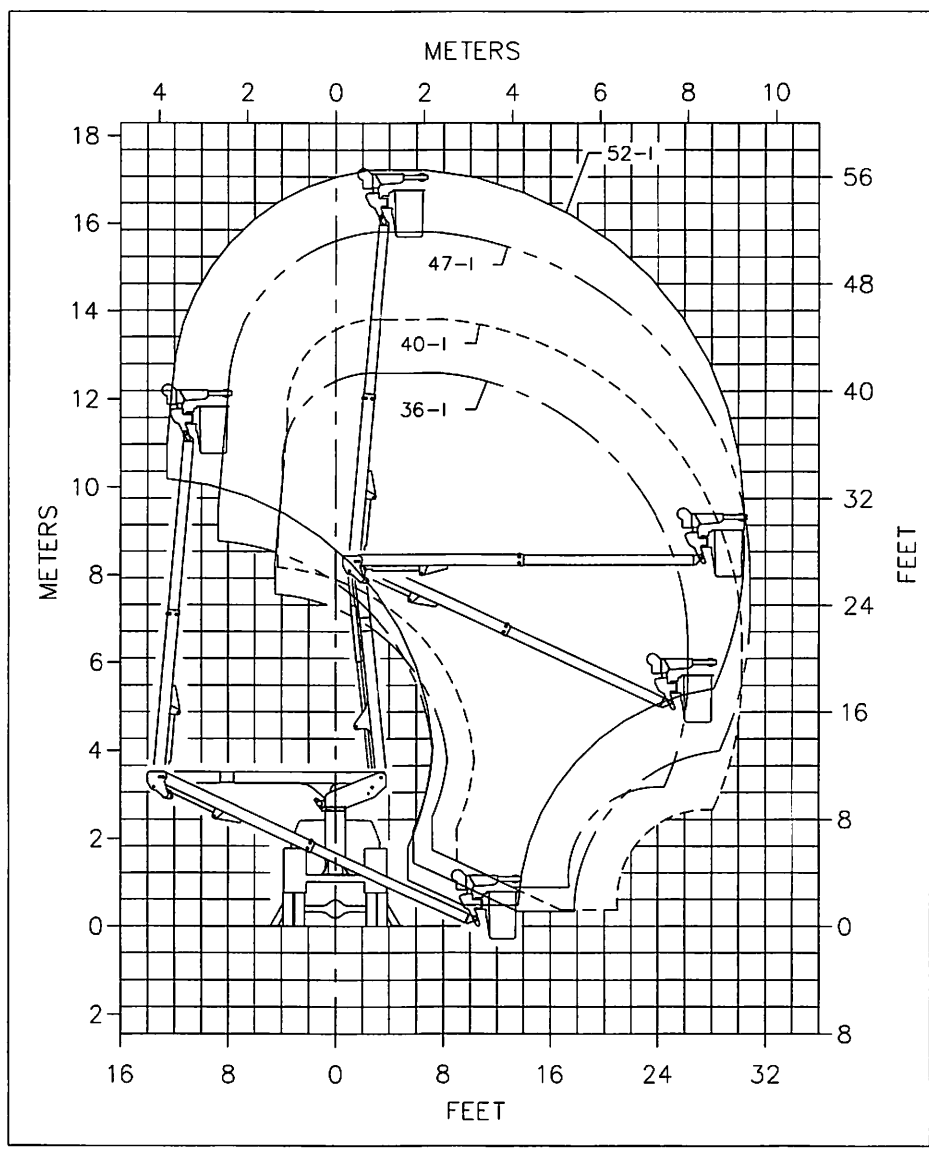

UNLESS OTHERWISE NOTED,  
 TOLERANCES:  
 DECIMALS  
 FRACTIONS ± 1/16  
 ANGLES ± 1'  
 MACHINED SURFACE FINISHES = 125/  
 PROJECTION OF VIEWS  
 ALL DIMENSIONS ARE IN INCHES

THIS PRINT CONTAINS CONFIDENTIAL INFORMATION AND IS SOLE PROPERTY OF TIME MANUFACTURING, AND IS NOT TO BE DISCLOSED, COPIED, OR REPRODUCED WITHOUT EXPRESSED PERMISSION OF TIME MANUFACTURING.

**TIME** MANUFACTURING COMPANY  
 WACO TEXAS

MATERIAL  
 ----

FINISH  
 ----

|          |           |
|----------|-----------|
| DWN. BY  | DATE      |
| LBR      | 12-13-07  |
| SIZE     | SCALE     |
| A        | 1=140     |
| EST WT # | MANUAL    |
|          | -         |
| SHEET    | DWG. NO.  |
| 1 OF 1   | 21938-DWG |

TITLE  
 REACH  
 DIAGRAM  
 VST-1







# SPECIFICATIONS

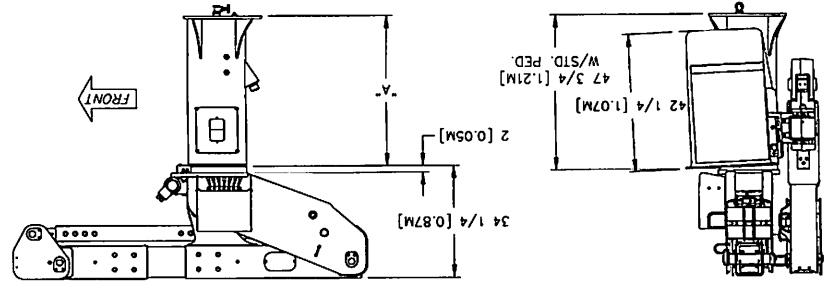
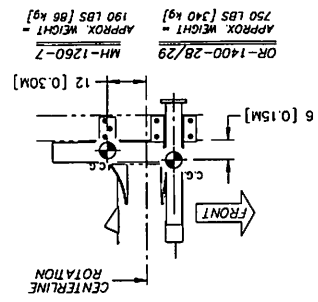
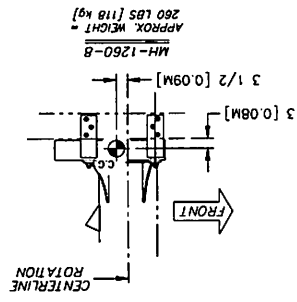
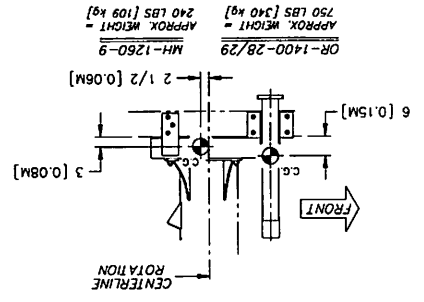
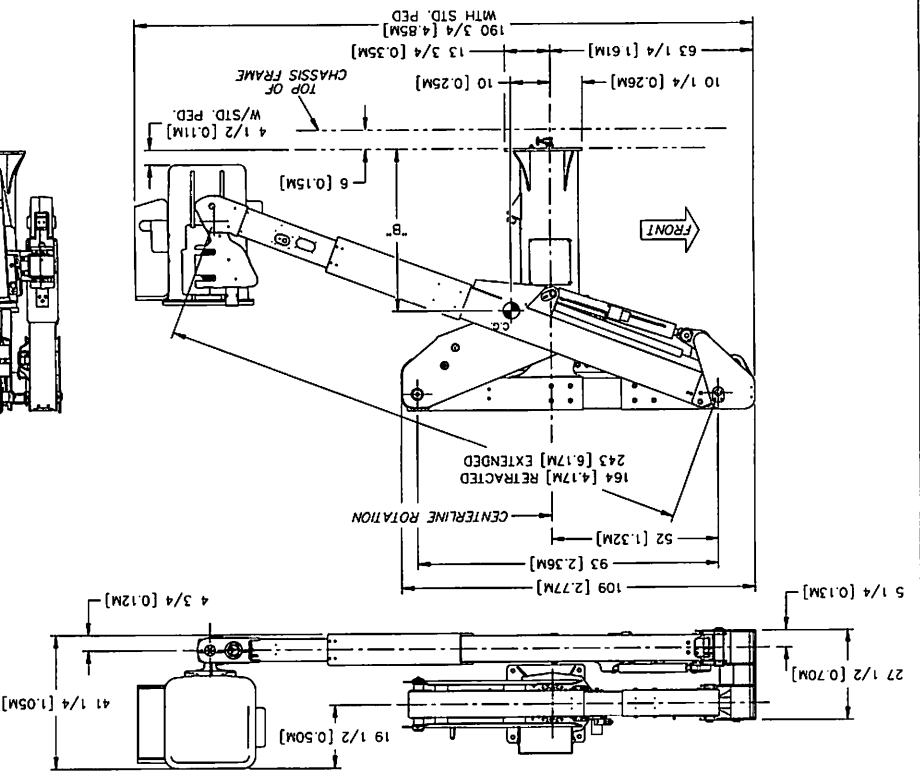

DIMENSIONAL CHART

| PEDestal OPTION | "A"    | "B" | WEIGHT * |
|-----------------|--------|-----|----------|
| P-1260-8        | 46 1/4 | 50  | 3200 LBS |
| P-1260-9        | 52 1/4 | 54  | 3220 LBS |
| P-1260-10       | 58 1/4 | 58  | 3240 LBS |
| P-1260-11       | 64 1/4 | 63  | 3260 LBS |
| (64" TALL)      | 64 1/4 | 63  | 1480 kg  |
| P-1260-12       | 58 1/4 | 54  | 3220 LBS |
| (58" TALL)      | 58 1/4 | 54  | 1460 kg  |
| P-1260-13       | 52 1/4 | 50  | 3200 LBS |
| (52" TALL)      | 52 1/4 | 50  | 1451 kg  |
| P-1260-14       | 58 1/4 | 58  | 3240 LBS |
| (58" TALL)      | 58 1/4 | 58  | 1470 kg  |
| P-1260-15       | 64 1/4 | 63  | 3260 LBS |
| (64" TALL)      | 64 1/4 | 63  | 1480 kg  |

- NOTES:
- 1.) ALL DIMENSIONS ARE IN INCHES WITH METRIC EQUIVALENTS IN METERS.
  - 2.) \* INDICATES WITHOUT OIL IN RESERVOIR, AND WITHOUT MOUNTING HARDWARE.
  - 3.) UPPER BOOM IS SHOWN AT STOWED POSITION.
  - 4.) P-1260-8 (46" TALL) PEDestal OPTION IS SHOWN.
  - 5.) ADD 150 LBS [68 kg] FOR JIB AND WINCH OPTION.
  - 6.) ADD 130 LBS [60 kg] FOR HYDRAULIC OIL IN RESERVOIR.

VERSALIFT VST-36-1/N OVERALL

DATE: 12-13-07  
LBR: B  
SCALE: 1:35  
EST. WT. # MANUAL: -  
SHEET: 1 OF 1  
DWG. NO. 21926-DWG

MANUFACTURING COMPANY: WACO TEXAS  
MATERIAL: TITANE

UNLESS OTHERWISE NOTED, ALL DIMENSIONS ARE IN INCHES.  
TOLERANCES: ANGLES ± 1/4°  
FINISH: FRESH

THIS DRAWING CONTAINS COMPANY PROPRIETARY INFORMATION AND IS NOT TO BE REPRODUCED OR TRANSMITTED IN ANY FORM OR BY ANY MEANS, ELECTRONIC OR MECHANICAL, INCLUDING PHOTOCOPYING, RECORDING, OR BY ANY INFORMATION STORAGE AND RETRIEVAL SYSTEM, WITHOUT THE WRITTEN PERMISSION OF THE MANUFACTURER.

|       |          |               |
|-------|----------|---------------|
| REV   | DATE     | DESCRIPTION   |
| 05618 | 12-13-07 | FIRST RELEASE |

# SPECIFICATIONS

|                                     |          |           |
|-------------------------------------|----------|-----------|
| VST-40-1/N<br>OVERALL               | DRG. NO. | 21927-DWG |
|                                     | SHEET    | 1 OF 1    |
| MANUFACTURING COMPANY<br>WACO TEXAS | DATE     | 12-13-07  |
|                                     | SCALE    | B<br>1=35 |
|                                     | REV.     |           |
|                                     | APP. BY  |           |

NOTES:  
 1.) ALL DIMENSIONS ARE IN INCHES WITH METRIC EQUIVALENTS IN METERS.  
 2.) \* INDICATES WITHOUT OIL IN RESERVOIR, AND WITHOUT MOUNTING HARDWARE.  
 3.) UPPER BOOM IS SHOWN AT STORED POSITION.  
 4.) P-1260-8 (46" TALL) PEDESTAL OPTION IS SHOWN.  
 5.) ADD 150 LBS [68 kg] FOR JIB AND WINCH OPTION.  
 6.) ADD 130 LBS [60 kg] FOR HYDRAULIC OIL IN RESERVOIR.

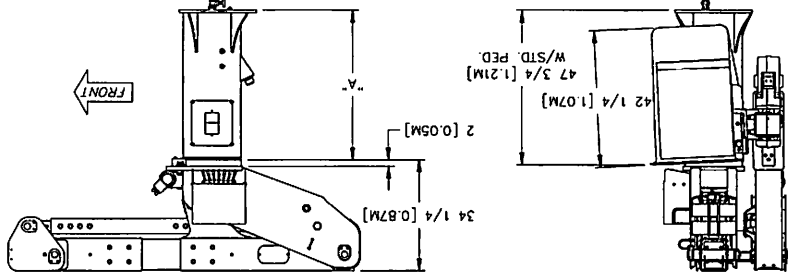

| PEDESTAL *<br>OPTION | "A"     | "B" | WEIGHT * |
|----------------------|---------|-----|----------|
| P-1260-8             | 46 1/4  | 50  | 3300 LBS |
| P-1260-9             | 52 1/4  | 54  | 3320 LBS |
| P-1260-10            | 58 1/4  | 58  | 3340 LBS |
| P-1260-11            | 64 1/4  | 62  | 3360 LBS |
| P-1260-12            | 70 1/4  | 66  | 3380 LBS |
| P-1260-13            | 76 1/4  | 70  | 3400 LBS |
| P-1260-14            | 82 1/4  | 74  | 3420 LBS |
| P-1260-15            | 88 1/4  | 78  | 3440 LBS |
| P-1260-16            | 94 1/4  | 82  | 3460 LBS |
| P-1260-17            | 100 1/4 | 86  | 3480 LBS |
| P-1260-18            | 106 1/4 | 90  | 3500 LBS |

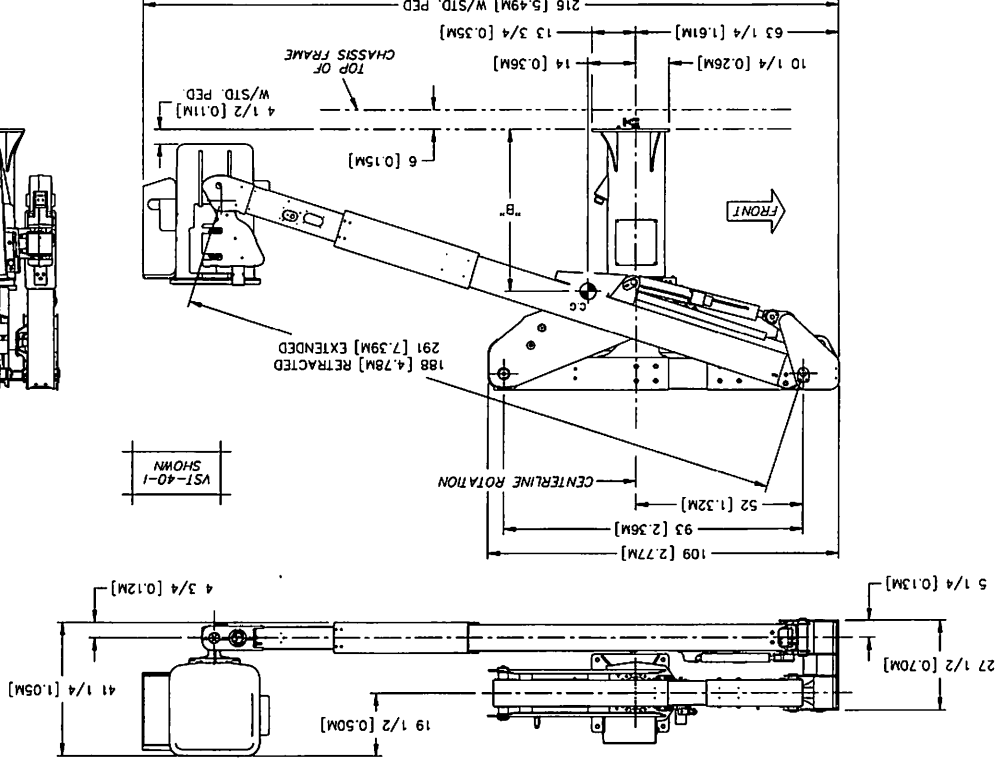
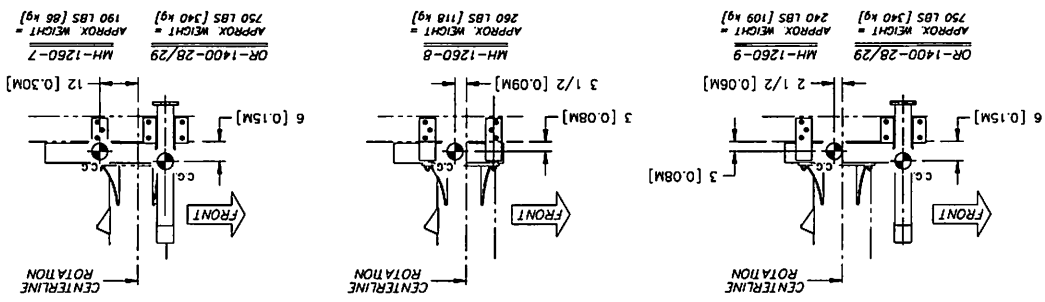

|      |      |    |       |         |      |
|------|------|----|-------|---------|------|
| REV. | DATE | BY | CHKD. | APP. BY | DATE |
|      |      |    |       |         |      |

# SPECIFICATIONS

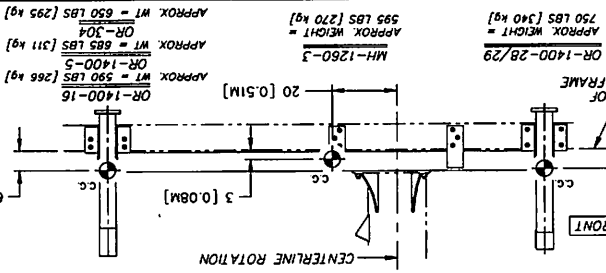
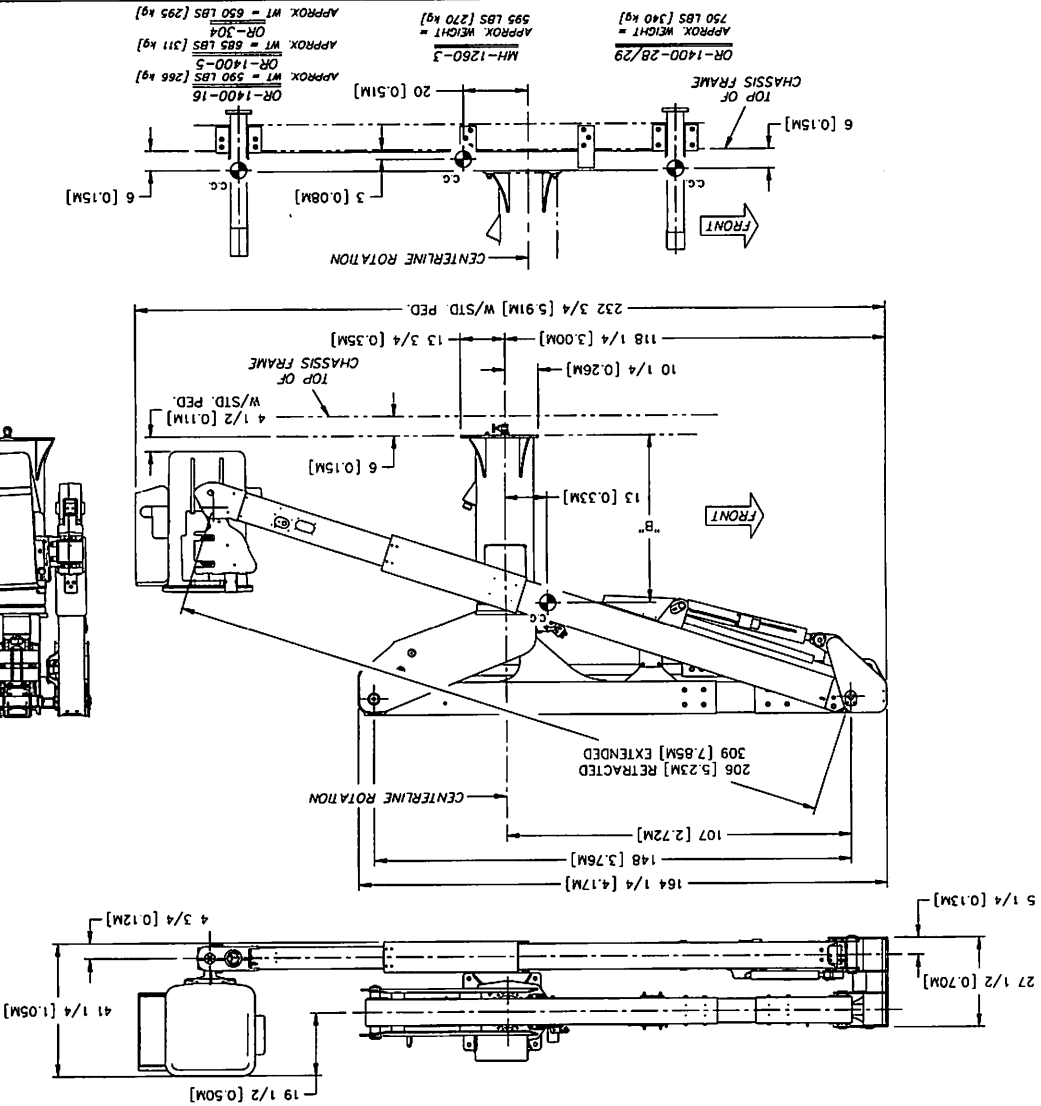

OR-1400-28/29 APPROX WEIGHT = 750 LBS [340 kg]  
 APPROX WEIGHT = 595 LBS [270 kg]  
 MH-1260-3 APPROX WEIGHT = 595 LBS [270 kg]  
 OR-304 APPROX WT = 685 LBS [311 kg]  
 OR-1400-5 APPROX WT = 590 LBS [266 kg]  
 OR-1400-16 APPROX WT = 650 LBS [295 kg]

DIMENSIONAL CHART

| PEDestal OPTION | "A"            | "B" | WEIGHT *           |
|-----------------|----------------|-----|--------------------|
| P-1260-B        | 46 1/4 [1.17M] | 53  | 3580 LBS [1620 kg] |
| P-1260-9        | 52 1/4 [1.33M] | 57  | 3600 LBS [1630 kg] |
| P-1260-10       | 58 1/4 [1.45M] | 60  | 3620 LBS [1630 kg] |
| P-1260-11       | 64 1/4 [1.63M] | 64  | 3640 LBS [1650 kg] |

STANDARD →

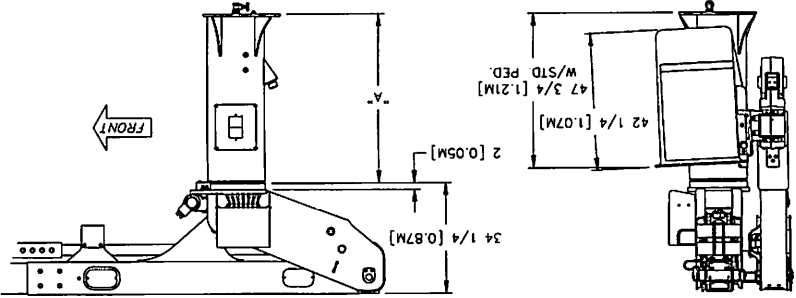

NOTES:  
 (1) ALL DIMENSIONS ARE IN INCHES WITH METRIC EQUIVALENTS IN METERS.  
 (2) \* INDICATES WITHOUT OIL IN RESERVOIR, AND WITHOUT MOUNTING HARDWARE.  
 (3) UPPER BOOM IS SHOWN AT STOWED POSITION.  
 (4) P-1260-9 (52" TALL) PEDestal OPTION IS SHOWN.  
 (5) ADD 150 LBS [68 kg] FOR JIB AND WINCH OPTION.  
 (6) ADD 130 LBS [60 kg] FOR HYDRAULIC OIL IN RESERVOIR.

|               |          |     |      |      |      |
|---------------|----------|-----|------|------|------|
| REV           | DATE     | BY  | CHKD | APPR | DATE |
| 04018         | 12-13-07 | LBN | DJM  | SMS  |      |
| DESCRIPTION   |          |     |      |      |      |
| FIRST RELEASE |          |     |      |      |      |

|                    |     |          |     |      |      |
|--------------------|-----|----------|-----|------|------|
| DATE               | REV | DATE     | BY  | CHKD | APPR |
| 12-13-07           | 01  | 12-13-07 | LBN | DJM  | SMS  |
| OVERALL            |     |          |     |      |      |
| VST-47-1           |     |          |     |      |      |
| 1 OF 1             |     |          |     |      |      |
| SHEET              |     |          |     |      |      |
| DWG. NO. 21928-DWG |     |          |     |      |      |



MANUFACTURING COMPANY  
 WACO TEXAS

LESS ORDERED OPTIONS  
 TOLERANCES  
 DIMENSIONS  
 UNLESS OTHERWISE SPECIFIED  
 ARE IN INCHES  
 DECIMALS  
 FRACTIONS  
 ARE TO BE USED  
 UNLESS OTHERWISE SPECIFIED  
 ALL DIMENSIONS ARE TO CENTERLINE  
 UNLESS OTHERWISE SPECIFIED  
 MATERIAL  
 SEE PARTS LIST FOR MATERIAL SPECIFICATIONS  
 THIS DRAWING IS THE PROPERTY OF TEXMATE  
 AND IS NOT TO BE REPRODUCED OR TRANSMITTED IN ANY FORM OR BY ANY MEANS  
 WITHOUT THE WRITTEN PERMISSION OF TEXMATE

|     |          |     |      |       |
|-----|----------|-----|------|-------|
| REV | DATE     | BY  | CHKD | APP'D |
| 1   | 12-13-07 | WAC | WAC  | WAC   |

REVISIONS  
 1) REVISION 1

DATE  
 12-13-07

SCALE  
 1"=40'

SHEET NO.  
 1 OF 1

DWG NO.  
 21929-DWG

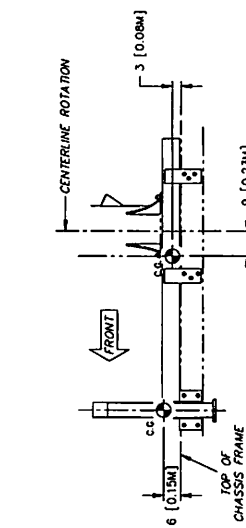

OR-1400-28/29  
 APPROX. WEIGHT  
 670 LBS [300 kg]

MH-1260-10  
 APPROX. WEIGHT  
 460 LBS [200 kg]

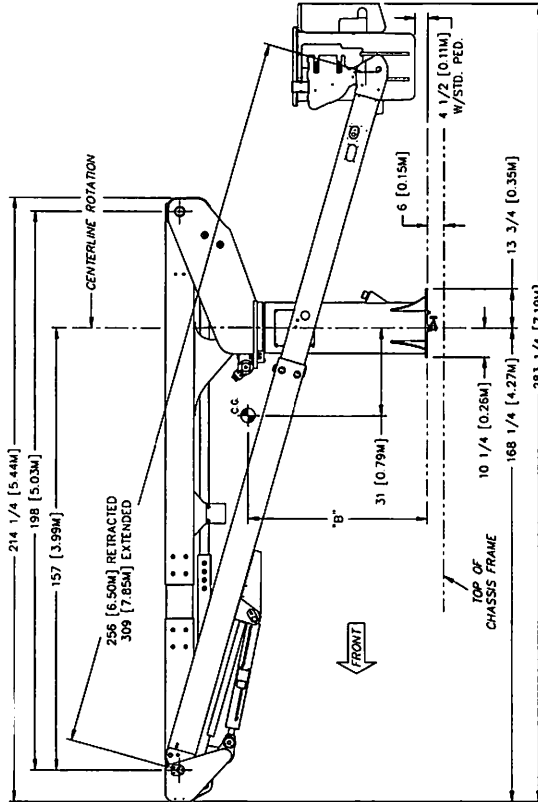
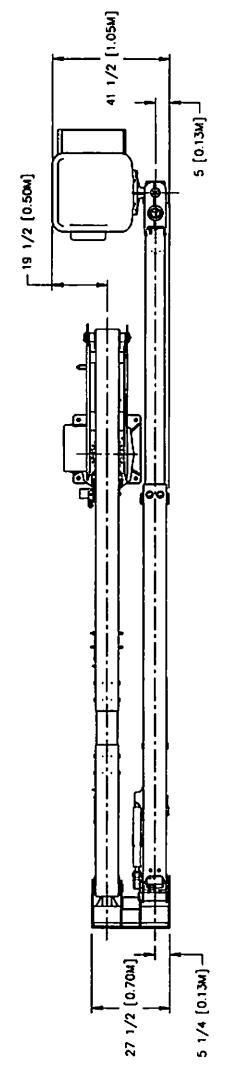
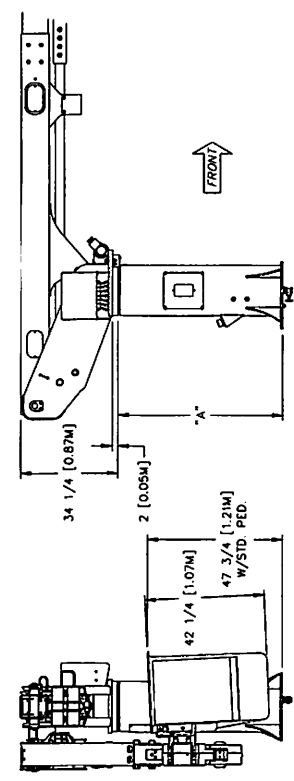

- NOTES:  
 1.) ALL DIMENSIONS ARE IN INCHES WITH METRIC EQUIVALENTS IN METERS  
 2.) \* INDICATES WITHOUT OIL IN RESERVOIR, AND WITHOUT MOUNTING HARDWARE  
 3.) UPPER BOOM IS SHOWN AT STONED POSITION  
 4.) P-1260-10 (56" TALL) PEDESTAL OPTION IS SHOWN.  
 5.) ADD 150 LBS (68 kg) FOR M3 AND M3C OPTION  
 6.) ADD 130 LBS (60 kg) FOR HYDRAULIC OIL IN RESERVOIR.

| PEDESTAL OPTION      | "A"            | "B"        | WEIGHT *           |
|----------------------|----------------|------------|--------------------|
| P-1260-B (48" TALL)  | 46 1/4 [1.17M] | 34 [0.86M] | 3760 LBS [1705 kg] |
| P-1260-10 (52" TALL) | 51 1/4 [1.30M] | 34 [0.86M] | 3760 LBS [1705 kg] |
| P-1260-11 (56" TALL) | 56 1/4 [1.43M] | 34 [0.86M] | 3820 LBS [1730 kg] |
| P-1260-11 (64" TALL) | 64 1/4 [1.63M] | 34 [0.86M] | 3820 LBS [1730 kg] |

STANDARD →

|                       |            |
|-----------------------|------------|
| DATE                  | 12-13-07   |
| SCALE                 | B 1"=40'   |
| SHEET                 | 1 OF 1     |
| MANUFACTURING COMPANY | WACO TEXAS |
| DATE                  | 12-13-07   |
| SCALE                 | B 1"=40'   |
| SHEET                 | 1 OF 1     |
| MANUFACTURING COMPANY | WACO TEXAS |
| DATE                  | 12-13-07   |
| SCALE                 | B 1"=40'   |
| SHEET                 | 1 OF 1     |
| MANUFACTURING COMPANY | WACO TEXAS |
| DATE                  | 12-13-07   |
| SCALE                 | B 1"=40'   |
| SHEET                 | 1 OF 1     |
| MANUFACTURING COMPANY | WACO TEXAS |

# SPECIFICATIONS



## VST-36-I VEHICLE SPECIFICATIONS

### With One Set of Outriggers behind Cab

#### 400 lbs Platform Capacity with Jib / 500 lbs Platform Capacity without Jib

|  |                             |
|--|-----------------------------|
| Cab-to-Rear Axle Dimension without material handling ..... | 60 in (1.5 m)               |
| Cab-to-Rear Axle Dimension with material handling .....    | 84 in (2.14 m)              |
| Frame Resisting Bending Moment .....                       | 500,000 in-lbs (57,000 N-m) |
| GVWR .....   | 17,500 lbs. (7940 kg)       |
| GAWR (Front) .....   | 7,000 lbs. (3175 kg)        |
| GAWR (Rear) .....  | 13,500 lbs. (6120 kg)       |
| Approximate Curb Weight for Stability .....                | 13,000 lbs. (5900 kg)       |

#### 500 lbs Platform Capacity with Jib / 600 lbs Platform Capacity without Jib

|   |                             |
|---|-----------------------------|
| Cab-to-Rear Axle Dimension .....            | 84 in (2.14 m)              |
| Frame Resisting Bending Moment .....        | 540,000 in-lbs (66,000 N-m) |
| GVWR .....                                  | 24,000 lbs. (10,880 kg)     |
| GAWR (Front) .....                          | 9,000 lbs. (4080 kg)        |
| GAWR (Rear) .....                           | 16,000 lbs. (7260 kg)       |
| Approximate Curb Weight for Stability ..... | 14,000 lbs. (6350 kg)       |

### With Two Sets of Outriggers and Full Length Subframe

#### 500 lbs Platform Capacity with Jib / 600 lbs Platform Capacity without Jib

|   |                             |
|---|-----------------------------|
| Cab-to-Rear Axle Dimension .....            | 84 in (2.14 m)              |
| Frame Resisting Bending Moment .....        | 410,000 in-lbs (47,000 N-m) |
| GVWR .....                                  | 17,500 lbs. (7940 kg)       |
| GAWR (Front) .....                          | 7,000 lbs. (3175 kg)        |
| GAWR (Rear) .....                           | 13,500 lbs. (6120 kg)       |
| Approximate Curb Weight for Stability ..... | 13,000 lbs. (5900 kg)       |

### With Torsion Bar(s)

#### 400 lbs Platform Capacity with Jib / 500 lbs Platform Capacity without Jib

|   |                             |
|---|-----------------------------|
| Cab-to-Rear Axle Dimension .....            | 84 in (2.14 m)              |
| Frame Resisting Bending Moment .....        | 500,000 in-lbs (57,000 N-m) |
| GVWR .....                                  | 30,000 lbs. (13,610 kg)     |
| GAWR (Front) .....                          | 10,000 lbs. (4540 kg)       |
| GAWR (Rear) .....                           | 20,000 lbs. (9070 kg)       |
| Approximate Curb Weight for Stability ..... | TBD                         |

#### NOTES:

- Actual GVWR and GAWR's should be based on the weight and location of the chassis, body, lift, ballast (if required), accessories, and the desired payload.
- Recommended GVWR and GAWR's listed above are based on typical installations with a 4x2 chassis. 4x4 and/or crew cab chassis will typically require higher axle ratings.
- The curb weight for stability will vary based on the rated platform capacity, mounting configuration, frame stiffness, and stability test requirements.
- To determine the Frame Resisting Bending Moment (RBM), use the formula below:
  - Section Modulus X Yield Strength = RBM
  - For example, the RBM of a 2008 Ford F-550 with reinforced frame is:  
17.2 x 36,000 = 619,200 in-lbs

SPECIFICATIONS



## VST-40-I VEHICLE SPECIFICATIONS

### With One Set of Outriggers behind Cab 300 lbs Platform Capacity with Jib / 400 lbs Platform Capacity without Jib

|   |                             |
|---|-----------------------------|
| Cab-to-Rear Axle Dimension .....            | 84 in (2.14 m)              |
| Frame Resisting Bending Moment .....        | 530,000 in-lbs (60,000 N-m) |
| GVWR .....                                  | 17,500 lbs. (7940 kg)       |
| GAWR (Front) .....                          | 7,000 lbs. (3175 kg)        |
| GAWR (Rear) .....                           | 13,500 lbs. (6120 kg)       |
| Approximate Curb Weight for Stability ..... | 13,500 lbs. (6120 kg)       |

### 500 lbs Platform Capacity with Jib / 600 lbs Platform Capacity without Jib

|   |                             |
|---|-----------------------------|
| Cab-to-Rear Axle Dimension .....            | 84 in (2.14 m)              |
| Frame Resisting Bending Moment .....        | 620,000 in-lbs (71,000 N-m) |
| GVWR .....                                  | 24,000 lbs. (10,890 kg)     |
| GAWR (Front) .....                          | 9,000 lbs. (4080 kg)        |
| GAWR (Rear) .....                           | 16,000 lbs. (7260 kg)       |
| Approximate Curb Weight for Stability ..... | 15,000 lbs. (6800 kg)       |

### With Two Sets of Outriggers and Full Length Subframe 500 lbs Platform Capacity with Jib / 600 lbs Platform Capacity without Jib

|   |                             |
|---|-----------------------------|
| Cab-to-Rear Axle Dimension .....            | 84 in (2.14 m)              |
| Frame Resisting Bending Moment .....        | 480,000 in-lbs (55,000 N-m) |
| GVWR .....                                  | 17,500 lbs. (7940 kg)       |
| GAWR (Front) .....                          | 7,000 lbs. (3175 kg)        |
| GAWR (Rear) .....                           | 13,500 lbs. (6120 kg)       |
| Approximate Curb Weight for Stability ..... | 14,500 lbs. (6580 kg)       |

### With Torsion Bar(s) 300 lbs Platform Capacity with Jib / 400 lbs Platform Capacity without Jib

|   |                             |
|---|-----------------------------|
| Cab-to-Rear Axle Dimension .....            | 84 in (2.14 m)              |
| Frame Resisting Bending Moment .....        | 530,000 in-lbs (60,000 N-m) |
| GVWR .....                                  | 30,000 lbs. (13,610 kg)     |
| GAWR (Front) .....                          | 10,000 lbs. (4540 kg)       |
| GAWR (Rear) .....                           | 20,000 lbs. (9070 kg)       |
| Approximate Curb Weight for Stability ..... | TBD                         |

#### NOTES:

1. Actual GVWR and GAWR's should be based on the weight and location of the chassis, body, lift, ballast (if required), accessories, and the desired payload.
2. Recommended GVWR and GAWR's listed above are based on typical installations with a 4x2 chassis. 4x4 and/or crew cab chassis will typically require higher axle ratings.
3. The curb weight for stability will vary based on the rated platform capacity, mounting configuration, frame stiffness, and stability test requirements.
4. To determine the Frame Resisting Bending Moment (RBM), use the formula below:
  - Section Modulus X Yield Strength = RBM
  - For example, the RBM of a 2008 Ford F-550 with reinforced frame is:  
17.2 x 36,000 = 619,200 in-lbs



## VST-47-I VEHICLE SPECIFICATIONS

### With One Set of Outriggers behind Cab

#### 400 lbs Platform Capacity with Jib / 500 lbs Platform Capacity without Jib

|   |                             |
|---|-----------------------------|
| Cab-to-Rear Axle Dimension .....            | 84 in (2.14 m)              |
| Frame Resisting Bending Moment .....        | 600,000 in-lbs (66,000 N-m) |
| GVWR .....                                  | 24,000 lbs. (10,890 kg)     |
| GAWR (Front) .....                          | 9,000 lbs. (4080 kg)        |
| GAWR (Rear) .....                           | 16,000 lbs. (7260 kg)       |
| Approximate Curb Weight for Stability ..... | 16,000 lbs. (7260 kg)       |

### With One Set of Outriggers behind Cab

#### 500 lbs Platform Capacity with Jib / 600 lbs Platform Capacity without Jib

|   |                             |
|---|-----------------------------|
| Cab-to-Rear Axle Dimension .....            | 84 in (2.14 m)              |
| Frame Resisting Bending Moment .....        | 620,000 in-lbs (70,000 N-m) |
| GVWR .....                                  | 24,000 lbs. (10,890 kg)     |
| GAWR (Front) .....                          | 9,000 lbs. (4080 kg)        |
| GAWR (Rear) .....                           | 16,000 lbs. (7260 kg)       |
| Approximate Curb Weight for Stability ..... | 16,500 lbs. (7480 kg)       |

### With Two Sets of Outriggers and Full Length Subframe

#### 400 lbs Platform Capacity with Jib / 500 lbs Platform Capacity without Jib

|   |                             |
|---|-----------------------------|
| Cab-to-Rear Axle Dimension .....            | 84 in (2.14 m)              |
| Frame Resisting Bending Moment .....        | 360,000 in-lbs (41,000 N-m) |
| GVWR .....                                  | 17,500 lbs. (7940 kg)       |
| GAWR (Front) .....                          | 7,000 lbs. (3175 kg)        |
| GAWR (Rear) .....                           | 13,500 lbs. (6120 kg)       |
| Approximate Curb Weight for Stability ..... | 14,500 lbs. (6580 kg)       |

### With Two Sets of Outriggers and Full Length Subframe

#### 500 lbs Platform Capacity with Jib / 600 lbs Platform Capacity without Jib

|   |                             |
|---|-----------------------------|
| Cab-to-Rear Axle Dimension .....            | 84 in (2.14 m)              |
| Frame Resisting Bending Moment .....        | 380,000 in-lbs (43,000 N-m) |
| GVWR .....                                  | 17,500 lbs. (7940 kg)       |
| GAWR (Front) .....                          | 7,000 lbs. (3175 kg)        |
| GAWR (Rear) .....                           | 13,500 lbs. (6120 kg)       |
| Approximate Curb Weight for Stability ..... | 15,000 lbs. (6800 kg)       |

#### NOTES:

- Actual GVWR and GAWR's should be based on the weight and location of the chassis, body, lift, ballast (if required), accessories, and the desired payload.
- Recommended GVWR and GAWR's listed above are based on typical installations with a 4x2 chassis. 4x4 and/or crew cab chassis will typically require higher axle ratings.
- The curb weight for stability will vary based on the rated platform capacity, mounting configuration, frame stiffness, and stability test requirements.
- To determine the Frame Resisting Bending Moment (RBM), use the formula below:
  - Section Modulus X Yield Strength = RBM
  - For example, the RBM of a 2008 Ford F-550 with reinforced frame is:  
17.2 x 36,000 = 619,200 in-lbs

SPECIFICATIONS



## VST-52-I VEHICLE SPECIFICATIONS

**With One Set of Outriggers behind Cab  
400 lbs Platform Capacity with Jib / 500 lbs Platform Capacity without Jib**

|   |                             |
|---|-----------------------------|
| Cab-to-Rear Axle Dimension .....            | 102 in (2.6 m)              |
| Frame Resisting Bending Moment .....        | 580,000 in-lbs (66,000 N-m) |
| GVWR .....                                  | 24,000 lbs. (10,890 kg)     |
| GAWR (Front) .....                          | 9,000 lbs. (4080 kg)        |
| GAWR (Rear) .....                           | 16,000 lbs. (7260 kg)       |
| Approximate Curb Weight for Stability ..... | 17,000 lbs. (7712 kg)       |

**With One Set of Outriggers behind Cab  
500 lbs Platform Capacity with Jib / 600 lbs Platform Capacity without Jib**

|   |                             |
|---|-----------------------------|
| Cab-to-Rear Axle Dimension .....            | 102 in (2.6 m)              |
| Frame Resisting Bending Moment .....        | 610,000 in-lbs (69,000 N-m) |
| GVWR .....                                  | 24,000 lbs. (10,890 kg)     |
| GAWR (Front) .....                          | 9,000 lbs. (4080 kg)        |
| GAWR (Rear) .....                           | 16,000 lbs. (7260 kg)       |
| Approximate Curb Weight for Stability ..... | 17,300 lbs. (7850 kg)       |

### NOTES:

1. Actual GVWR and GAWR's should be based on the weight and location of the chassis, body, lift, ballast (if required), accessories, and the desired payload.
2. Recommended GVWR and GAWR's listed above are based on typical installations with a 4x2 chassis. 4x4 and/or crew cab chassis will typically require higher axle ratings.
3. The curb weight for stability will vary based on the rated platform capacity, mounting configuration, frame stiffness, and stability test requirements.
4. To determine the Frame Resisting Bending Moment (RBM), use the formula below:
  - Section Modulus X Yield Strength = RBM
  - For example, the RBM of a 2008 Ford F-550 with reinforced frame is:  
 $17.2 \times 36,000 = 619,200$  in-lbs

SPECIFICATIONS







SPECIFICATIONS

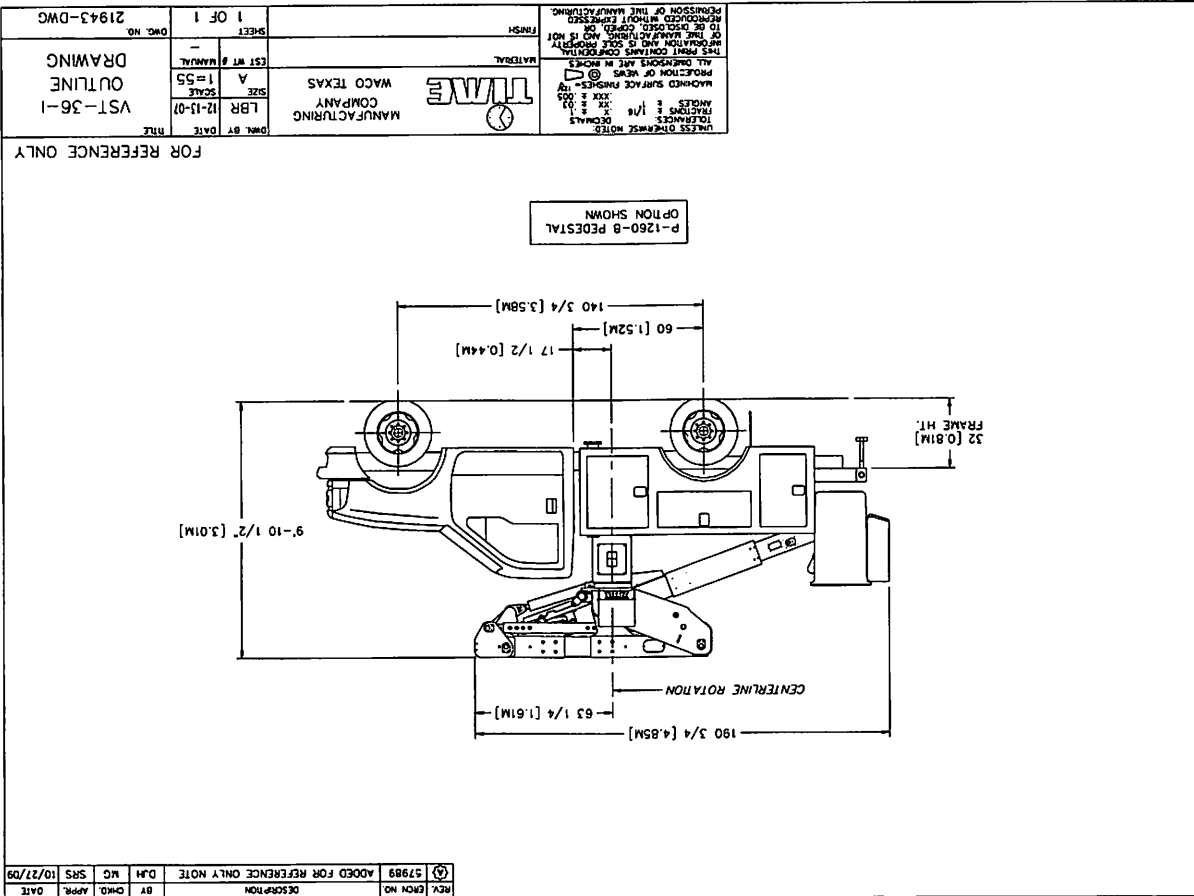
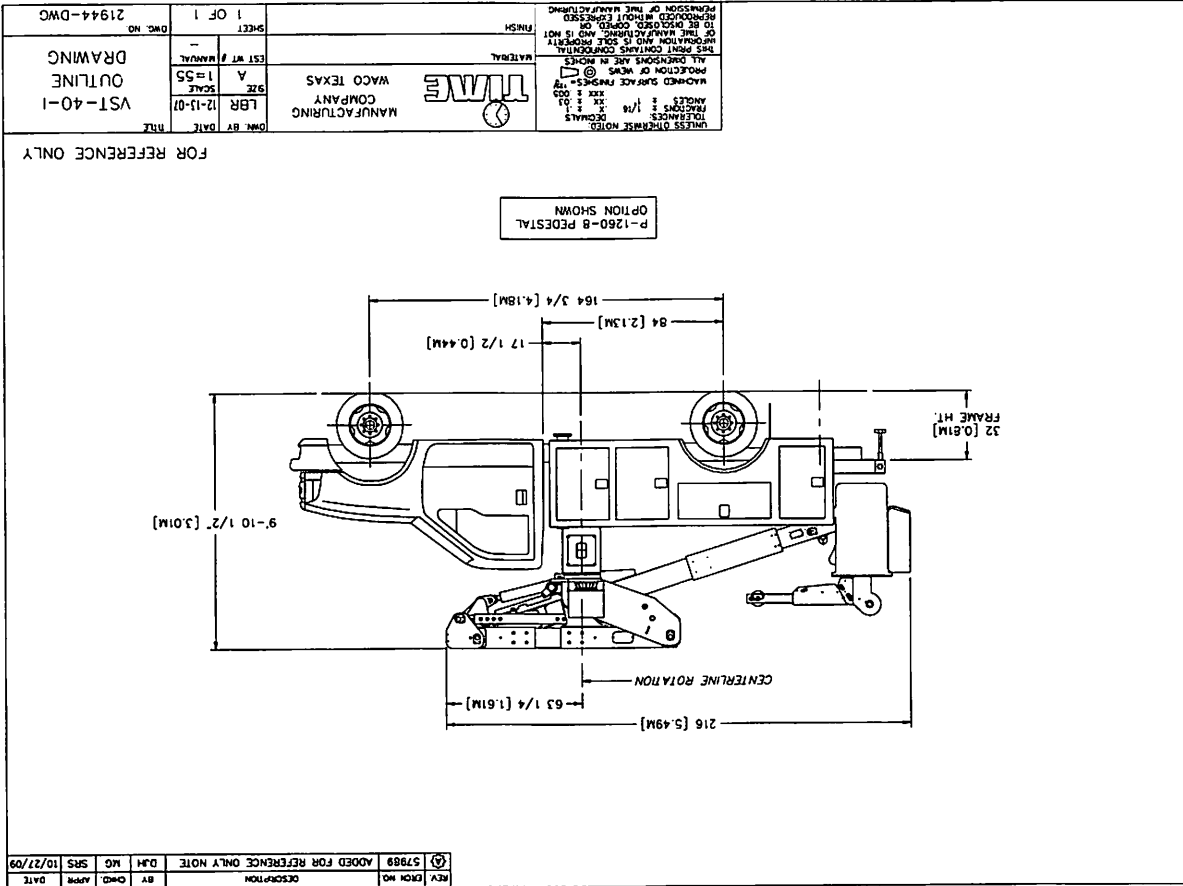

| REV. | DRWN NO. | DESCRIPTION                   | BY     | CHKD. | APPR. | DATE     |
|------|----------|-------------------------------|--------|-------|-------|----------|
| ④    | 57989    | ADDED FOR REFERENCE ONLY NOTE | D.J.H. | MG    | SRS   | 10/27/09 |

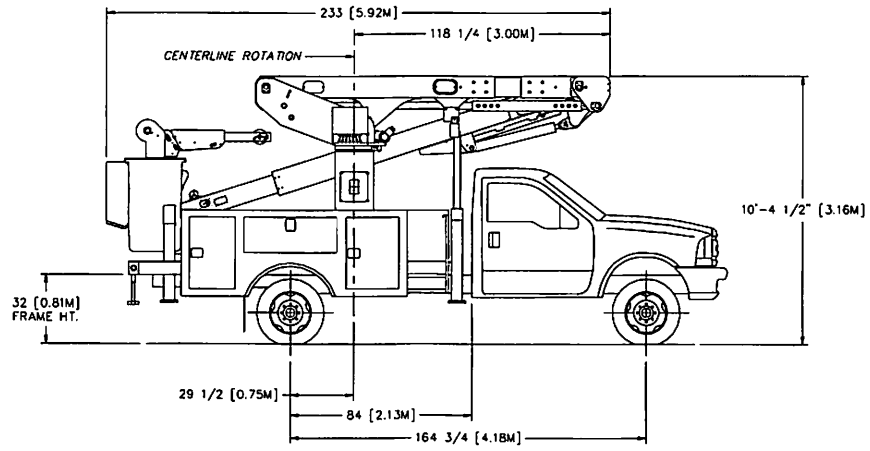

P-1260-9 PEDESTAL  
OPTION SHOWN

FOR REFERENCE ONLY

|  |  |                                     |            |           |          |
|--|--|-------------------------------------|------------|-----------|----------|
| <small>UNLESS OTHERWISE NOTED:<br/>TOLERANCES: FRACTIONS ± 1/16 DECIMALS .01 ANGLES ± 1° MACHINED SURFACE FINISHES = .005 PROJECTION OF VIEWS = 1st ALL DIMENSIONS ARE IN INCHES</small><br><small>THIS PRINT CONTAINS CONFIDENTIAL INFORMATION AND IS SOLE PROPERTY OF THE MANUFACTURING COMPANY AND IS NOT TO BE DISCLOSED, COPIED, OR REPRODUCED WITHOUT EXPRESSED PERMISSION OF THE MANUFACTURING COMPANY.</small> |  | MANUFACTURING COMPANY<br>WACO TEXAS | OWN. BY    | DATE      | TITLE    |
|  |  |                                     | LBR        | 12-13-07  | VST-47-1 |
|  |  |                                     | SIZE       | SCALE     | OUTLINE  |
|  |  |                                     | A          | 1=55      | DRAWING  |
|  |  |                                     | EST. WT. # | MANUAL    |          |
|  |  |                                     | SHEET      | OWC. NO.  |          |
|  |  |                                     | 1 OF 1     | 21945-DWG |          |

| REV. | DRWN NO. | DESCRIPTION                   | BY     | CHKD. | APPR. | DATE     |
|------|----------|-------------------------------|--------|-------|-------|----------|
| ④    | 57989    | ADDED FOR REFERENCE ONLY NOTE | D.J.H. | MG    | SRS   | 10/27/09 |

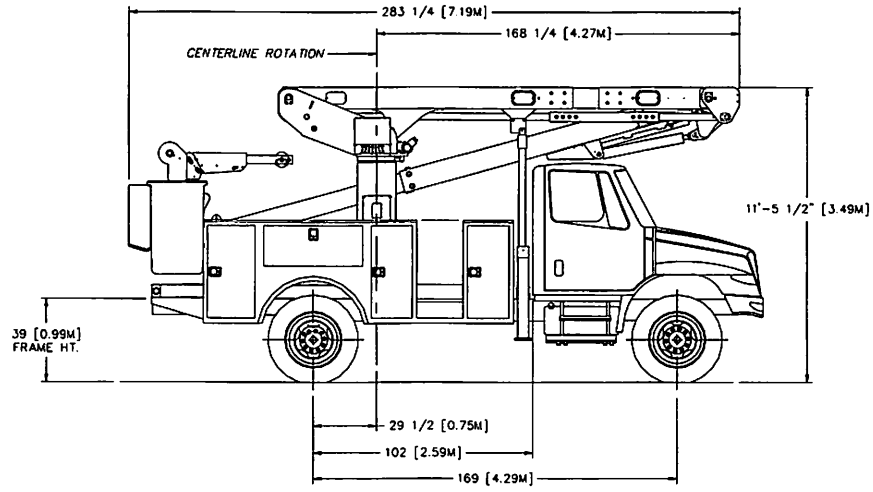

P-1260-10 PEDESTAL  
OPTION SHOWN

FOR REFERENCE ONLY

|  |  |                                     |            |           |          |
|--|--|-------------------------------------|------------|-----------|----------|
| <small>UNLESS OTHERWISE NOTED:<br/>TOLERANCES: FRACTIONS ± 1/16 DECIMALS .01 ANGLES ± 1° MACHINED SURFACE FINISHES = .005 PROJECTION OF VIEWS = 1st ALL DIMENSIONS ARE IN INCHES</small><br><small>THIS PRINT CONTAINS CONFIDENTIAL INFORMATION AND IS SOLE PROPERTY OF THE MANUFACTURING COMPANY AND IS NOT TO BE DISCLOSED, COPIED, OR REPRODUCED WITHOUT EXPRESSED PERMISSION OF THE MANUFACTURING COMPANY.</small> |  | MANUFACTURING COMPANY<br>WACO TEXAS | OWN. BY    | DATE      | TITLE    |
|  |  |                                     | LBR        | 12-13-07  | VST-52-1 |
|  |  |                                     | SIZE       | SCALE     | OUTLINE  |
|  |  |                                     | A          | 1=55      | DRAWING  |
|  |  |                                     | EST. WT. # | MANUAL    |          |
|  |  |                                     | SHEET      | OWC. NO.  |          |
|  |  |                                     | 1 OF 1     | 21946-DWG |          |



# OPERATION

This chapter provides operators and ground crew with recommended aerial lift operating procedures, descriptions and detailed operating information about the controls at each control station. Operators and ground crews are responsible for knowing and applying this information to job site situations.

Only properly trained operators are qualified to operate the Versalift aerial lift. Operator training shall include complete instruction and understanding of the manufacturer's manuals, employer's work rules, and all related governmental regulations. Prior to operation from the platform the machine must be operating properly, must have been installed properly, inspected, and maintained in accordance with the manufacturer's instructions. All safety signs, guards, and covers must be in place and in proper condition.

**⚠ DANGER: AN UNTRAINED OR CARELESS OPERATOR SUBJECTS HIM/HERSELF AND OTHERS TO DEATH OR SERIOUS INJURY.**

It is the responsibility of the operator and ground crew to make certain that the identification, operation, and instructional decals are not lost, damaged, or illegible. If these conditions exist the decals must be replaced before lift operation. Refer to the Decal Placement illustration in Section 6 of this manual for decal location and parts listing.

**PRIOR TO OPERATING THE AERIAL LIFT, REFER TO "DAILY VISUAL INSPECTION", SECTION 6 OF THIS MANUAL. DAILY VISUAL INSPECTION MUST BE PERFORMED BEFORE OPERATING THE LIFT.**

## POSITIONING THE VERSALIFT FOR OPERATION

This section describes proper positioning of the Versalift aerial lift so that it will be as stable and useful as possible. The information in this section includes orientation of the truck at the work site, a checklist of responsibilities before leaving the truck cab, requirements after leaving the truck cab, and engaging the outriggers.

### ORIENTING THE TRUCK AT THE WORK SITE -

Be sure to park the truck on firm level ground. Do not operate the Versalift unit on a slope greater than 5 degrees (1 foot rise in 12 feet) on units not equipped with outriggers. On units with outriggers, aerial device

must be leveled within 2° of horizontal prior to operation. Refer to slope indicators provided on the chassis to show whether the aerial device is positioned within limits permitted. Slope reduces the vehicle's stability and places additional stress on the lift and components. Maintaining the correct tire pressure and engaging the outriggers (if so equipped) contribute to vehicle stability. Refer to the subtitle "Outriggers" in this section for further details on engaging the outriggers. If there is any doubt about vehicle stability under any condition, do not operate the lift.

**⚠ DANGER: NEVER OPERATE THE LIFT ON A SLOPE GREATER THAN 5°. WITHOUT PROPER STABILITY THE UNIT MAY TIP RESULTING IN DEATH OR SERIOUS INJURY.**

### RESPONSIBILITIES BEFORE LEAVING THE TRUCK CAB -

Perform the following steps in preparing to operate the aerial-lift. It is assumed that the truck engine is still running. However, if the lift hydraulics are powered by an auxiliary engine (optional power unit) then it is not necessary for the truck engine to remain running.

1. Set the parking brake and the brake lock (if so equipped).
2. Shift the truck transmission into neutral (manual transmission) or park (automatic transmission).
3. Turn on the warning light flashers.
4. Depress the clutch and engage the PTO, if so equipped.
5. Activate the master control with the toggle switch on the truck dashboard. A red light next to the toggle switch on the dashboard indicates when the master control system is energized. The truck ignition must be on unless equipped with an auxiliary engine.

### REQUIREMENTS AFTER LEAVING THE TRUCK CAB:

1. Check wind and weather conditions. Do not operate the platform if wind gust exceeds 30 mph (48 km/hr) or if there is a threat of electrical storm.
2. After leaving the cab chock the wheels. This is extremely important because the brake systems on some larger trucks have a critical weakness. They may be engaged by locking the drive shaft

behind the transmission. If the weight is reduced from one of the rear wheels, by the position of the lift, the truck differential can allow the truck to roll. Refer to Figure 4.1 diagram for proper way of chocking the wheels.

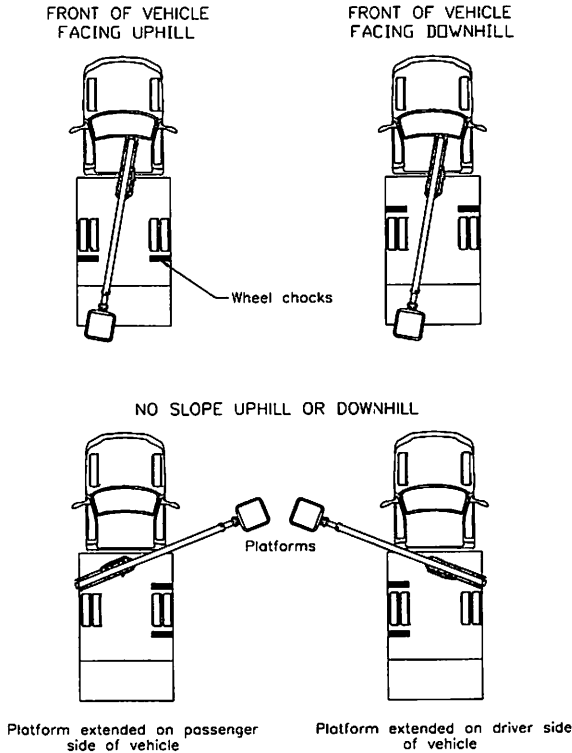

**Wheel Chocking Diagram**  
Figure 4.1

**⚠ DANGER: NEVER OPERATE THE LIFT WITHOUT SETTING THE PARKING BRAKE AND CHOCKING THE WHEELS. A ROLLING TRUCK MAY CAUSE AN ACCIDENT RESULTING IN DEATH OR SERIOUS INJURY.**

3. Set up adequate cones or barricades to mark the boundaries of the work site and alert pedestrians and motorists. Never work outside the boundaries.

**OUTRIGGERS (if equipped) - To operate the outriggers see "Outrigger Controls" in this section.**

**⚠ DANGER: NEVER OPERATE WITHOUT EXTENDING THE OUTRIGGERS (IF EQUIPPED). WITHOUT PROPER OUTRIGGER EXTENSION THE UNIT MAY TIP RESULTING IN DEATH OR SERIOUS INJURY.**

After the truck has been properly parked on level ground, and the outriggers have a clear path to the ground, lower all the outriggers until they firmly contact the ground. When the ground is too soft for the outriggers to be effective, place outrigger pads on the ground to increase the bearing area.

If the truck is parked on sloping ground so that one side of the truck is lower than the other side, extend the low-side outrigger first so that firm contact is made with the ground. This will avoid tilting the truck even more to the low side when the high-side outrigger is lowered.

If one or both outriggers (of a pair) are not fully extended, the outrigger spread is reduced (A-Frame outriggers only). This reduces the stability of the aerial lift. For example, when an outrigger rests on a curb the outrigger spread is reduced.

The stability of the truck depends on the unit's gross weight, firmness and slope of the ground, weight in the platform, tire pressure, and outrigger spread. These factors are widely variable and caution must be used when determining the stability of the unit. If, under any condition, there is doubt about vehicle stability do not operate the lift.

## AERIAL LIFT OPERATIONS

This section emphasizes overall operating practices for aerial lift operations. This information is presented in the order of probable use while operating first from the ground, then from the platform and close to energized conductors.

### Start Up Procedures When Operating From the Ground:

Position the truck as described in this section.

In extremely cold weather allow the aerial lift to idle a few minutes before engaging a load. Further consideration of cold weather operation is addressed in "Hydraulic Oil Recommendations" in Service Procedures Section of the Service Manual.

After the outriggers (if so equipped) have been lowered, disengage the upper-boom tie-down strap. Select lower controls with the selector lever. Refer to this section for a diagram of the lower controls. Caution: if an aerial device has set idle for an extended length of time (i.e. overnight) operate it from the lower controls through its full range of motion several times before an operator enters the platform. This procedure confirms that the lift is operating

properly and purges any air that may have become entrapped in the hydraulic system.

If there is any kind of malfunction during this test run, shut down the unit immediately. Do not operate the lift again until the problem has been corrected by the service department.

Operate each lift function from the lower controls by constantly holding the 3-position selector valve control handle in the lower controls position while slowly moving the appropriate spring-loaded control handle in the desired direction, as indicated by the decal, until motion begins. All boom movements should be started and stopped gradually.

**⚠ DANGER: NEVER REVERSE OR STOP THE DIRECTION OF LIFT TRAVEL SUDDENLY AND AVOID REACHING THE END OF BOOM RANGE AT EXCESSIVE SPEEDS. STRUCTURAL DAMAGE OR INSTABILITY MAY RESULT CAUSING DEATH OR SERIOUS INJURY.**

#### Operating Procedures At The Platform:

Complete the start-up procedure from the ground before selecting the upper controls with the 3-position control selector. In order to operate the lift from the platform, select the upper controls with the 3-position selector lever at the lower control station. Verify that the upper-boom tie-down strap is disengaged. Using the step(s) provided, carefully enter the platform. Safety regulations require the operator be secured with a personnel restraint system to the lift. The lanyard shall be attached to the safety belt/harness and the other end connected to the lanyard anchor on the platform support weldment. The safety belt must be rotated so that the lanyard connection is centered on the back of the operator.

**⚠ DANGER: NEVER OPERATE ANY AERIAL EQUIPMENT WITHOUT WEARING AN APPROVED PERSONNEL RESTRAINT SYSTEM ATTACHED TO THE LANYARD ANCHOR ON THE PLATFORM SUPPORT WELDMENT. FAILURE TO SECURE THE SAFETY BELT AND LANYARD MAY RESULT IN DEATH OR SERIOUS INJURY IN THE EVENT OF A FALL FROM THE PLATFORM.**

Before operating the lift, the operator should study "Upper Control Operation" in this section.

#### Operating Where Electrical Hazards Are Present:

It is imperative that the aerial device operator understand the dangers associated with operating near electrical hazards. Due to the work involved, the ordinary uses of aerial-lift often place the operator, others in the platform, and ground crew in the vicinity of electrical lines and equipment where grave danger exists. These dangers can only be avoided by the constant care of an operator who is aware of these dangers, knows the limitations of the aerial lift and its insulating sections, and knows how to protect her/himself and the crew from these dangers.

**⚠ DANGER: ALL COMPONENTS IN THE PLATFORM AREA, INCLUDING THE CONTROLS, JIB POLE, COVERS, ETC. SHALL BE CONSIDERED ELECTRICALLY CONNECTED, AND NOT INSULATED OR ISOLATED. THESE COMPONENTS MAY CONDUCT ELECTRICITY RESULTING IN DEATH OR SERIOUS INJURY.**

The insulation capabilities of this aerial lift are defined by the rated line voltage on the ANSI A92.2 data plate on the lift. Although the Versalift provides insulated booms, no aerial lift can provide protection from contact with or proximity to an electrically charged power line when you are in contact with, or in proximity to another power line. Maintain safe clearances from electrical power lines in accordance with applicable government regulations. Make certain to allow clearance for boom, platform, and electrical line sway and deflection.

**⚠ DANGER: CONTACT WITH, OR INADEQUATE CLEARANCE FROM, ELECTRICAL POWER LINES AND APPARATUS WILL CAUSE DEATH OR SERIOUS INJURY.**

The accumulation of dirt and moisture on insulated booms degrades the insulation. Be sure the booms are clean and dry. Remember that the inside of a boom may be wet even when the outside is dry. Any equipment which bridges between the platform and the ground voids the insulation and must be avoided when working near areas of electrical hazard.

**⚠ DANGER: EQUIPMENT WHICH BRIDGES BETWEEN THE PLATFORM AND GROUND RENDERS THE INSULATION USELESS AND MAY RESULT IN DEATH OR SERIOUS**

## **INJURY IN THE EVENT OF AN ELECTRIC SHOCK.**

**⚠ DANGER:** GIVE WARNING AND NEVER ALLOW ANYONE ON THE GROUND TO TOUCH THE UNIT WHEN THE LIFT IS BEING USED TO WORK ON OR NEAR ELECTRICAL LINES. IF THE UNIT BECOMES ENERGIZED DEATH OR SERIOUS INJURY WILL RESULT FROM CONTACT WITH THE UNIT.

**⚠ DANGER:** CONTACT BETWEEN AN ELECTRICALLY CHARGED WIRE AND A METAL PART OF THE BOOM MAY CAUSE THE WIRE TO BURN THROUGH, LETTING THE TWO WIRE ENDS FALL TOWARD THE GROUND. THIS WILL CAUSE DEATH OR SERIOUS INJURY TO INDIVIDUALS ON THE GROUND.

As stated previously, it is the responsibility of the operator and the ground crew to know and understand the capabilities and limitations of the aerial lift and hazards associated with operation near electric lines or components. In addition they must apply this knowledge to situations that arise on the job for safe and efficient operation.

## **CAB CONTROL OPERATION**

The cab controls include the master control, the engine start/stop control, and the PTO shifter.

**MASTER CONTROL (Standard)** - The master control consists of a toggle switch and a light mounted on the dashboard of the truck. The toggle switch is used to energize or de-energize the start/stop system and the throttle control options. When the light is on the toggle switch is energizing these systems.

**ENGINE START/STOP (Standard)** - The engine start/stop is a push button control that is usually mounted on the dashboard of the truck. The system is activated by pushing and holding the button momentarily to "start" the engine. If the engine does not crank then the start/stop button may require a second push to get the latching relay into the "start" position so the truck engine will turn over. Then to turn the engine off press the start/stop button again. This feature is especially convenient when the lift is being operated from the lower (turret) controls.

**⚠ DANGER: THE TRUCK TRANSMISSION**

**MUST BE IN NEUTRAL OR PARK BEFORE USING THE ENGINE START/STOP. STARTING THE ENGINE WITH THE TRUCK IN GEAR WILL CAUSE MOVEMENT WHICH MAY CAUSE DEATH OR SERIOUS INJURY TO THE OPERATOR OR ANYONE IN THE PATH OF THE TRUCK.**

**POWER-TAKE-OFF(PTO) (If So Equipped.)** - The power-take-off is a gearbox used to transmit power from the truck transmission to the hydraulic pump, providing hydraulic oil for the aerial lift functions. The PTO control consists of a toggle switch and a red light mounted in the truck dashboard. When the red (PTO) indicator is lighted the PTO is activated. The operator must never drive the truck with the PTO engaged.

**⚠ CAUTION: DRIVING WITH THE PTO ENGAGED MAY DAMAGE THE TRANSMISSION, PUMP, AND/OR THE PTO.**

To engage the PTO properly refer to the operating instructions located in the PTO manufacturer's owner manual. If the PTO control is not responding properly or if the manufacturer's operating decals are not posted in the cab (near the control) notify the appropriate personnel for correction.

## **GROUND CONTROL OPERATION**

The Versalift ground controls may include one or more of the following controls: outrigger, outrigger/boom interlock, and tool power. Ground controls are usually mounted on panels in the rear bumper of the truck or below the deck. Descriptions and operating procedures for these controls are given in the following text.

**OUTRIGGER OPERATION** - The outriggers (if so equipped) should always be extended to provide stability for the aerial lift. The outrigger controls consist of a control selector and a control valve as shown, Figure 4.2.

**CONTROL SELECTOR AND OUTRIGGER/BOOM INTERLOCK** - The outrigger/boom interlock is a feature designed to prevent the lift from being operated until the outriggers are properly extended. The interlock also prevents the outriggers from being retracted before the lift is properly stored. This option is particularly useful in keeping unauthorized personnel from operating the outriggers while an operator is working aloft.

**Note:** *The operation of an outrigger interlocking device(s) does not assure aerial device stability. It serves only to remind the operator that the outriggers have not been deployed.*

The controls for operating the outrigger/boom interlock include a detented control selector and a control valve. These controls are usually mounted in the ground control panel similar to the arrangement shown in Figure 4.2 below. ANSI A92.2 standards require that the outrigger control valve be located where the operator can watch each outrigger raise and lower as the control valve lever is activated.

**Lowering the Outriggers With an Outrigger/Boom Interlock System:** To lower the outriggers select "ground controls" with the control selector. Then operate the outriggers as described previously. Select "lift controls" with the control selector in order to begin operating the booms.

**Retracting the Outriggers With an Outrigger/Boom Interlock System:** The booms must be stowed before the interlock system will allow the outriggers to be retracted. Stow the booms as described in this section, "Storing the Aerial Lift". Select "ground controls" with the detented control selector. Then raise the outriggers as described previously.

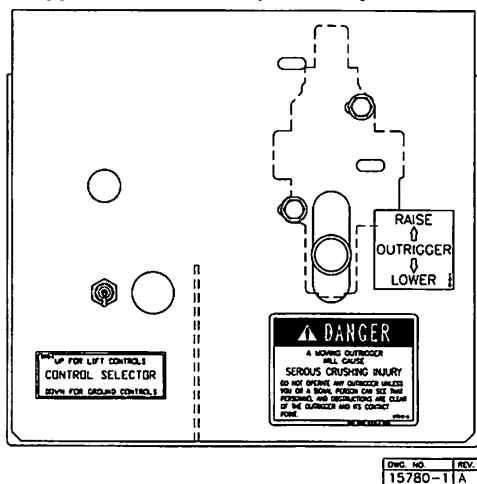

**Ground Control Panel With an Outrigger/Boom Interlock System**  
Figure 4.2

**HYDRAULIC TOOL OPERATION AT THE GROUND (Optional)** - Select ground controls at the lift/ground control selector then connect the hydraulic tool hoses to the tool power outlets (quick-disconnect couplings). Activate the tool-power valve by pulling the tool power valve knob "out". The other aerial lift controls will not respond while the hydraulic tools are being operated. To disconnect the hydraulic tools, the tool-power valve must be turned "off" so that the

pressure in the system is relieved. This is done by pushing the tool-power valve knob "in". Then the tool hoses can be disconnected safely and easily from the tool power outlets (quick-disconnect couplings). The tool-power controls are shown in Figure 4.3.

**⚠ WARNING: FAILURE TO RELIEVE PRESSURE TO THE TOOL PORTS BEFORE CONNECTING OR DISCONNECTING THE HYDRAULIC TOOL HOSES MAY RESULT IN A HIGH PRESSURE HYDRAULIC OIL SPRAY. THIS SPRAY OR MIST CAN PUNCTURE OR BECOME EMBEDDED BENEATH THE SKIN OR CONTAMINATE THE EYES. THESE CONDITIONS REQUIRE IMMEDIATE MEDICAL ATTENTION.**

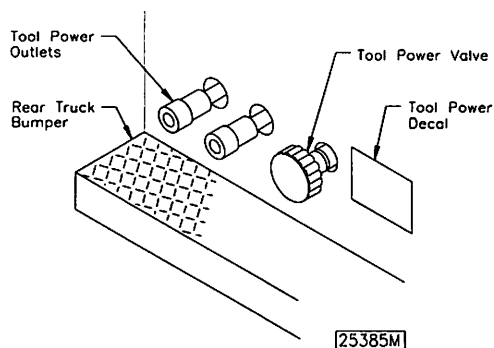

**Tool Power Controls**  
Figure 4.3

**LOWER CONTROL OPERATION**

**⚠ DANGER: DEATH OR SERIOUS INJURY MAY RESULT IF CHASSIS BECOMES ENERGIZED. DO NOT OPERATE THE AERIAL DEVICE WHILE CREATING A PATH TO THE GROUND.**

The Lower Controls are located on the turret as shown Figure 4.4.

**CONTROL SELECTOR LEVER** - The 3-position control selector is used to select operation of the aerial lift from the upper or lower controls. Also this control serves as the emergency stop for the upper controls. When a control station is selected the other is one inoperable.

**BOOM CONTROL LEVERS** - The remaining control levers at the lower control station are spring-loaded. The lower control decal identifies the function of each



control lever and indicates which direction to move the control lever for the desired movement. When released the control lever will return to the centered or neutral position and motion ceases.

**PLATFORM LEVELING CONTROL** - This control activates the hydraulic platform leveling to level the platform.

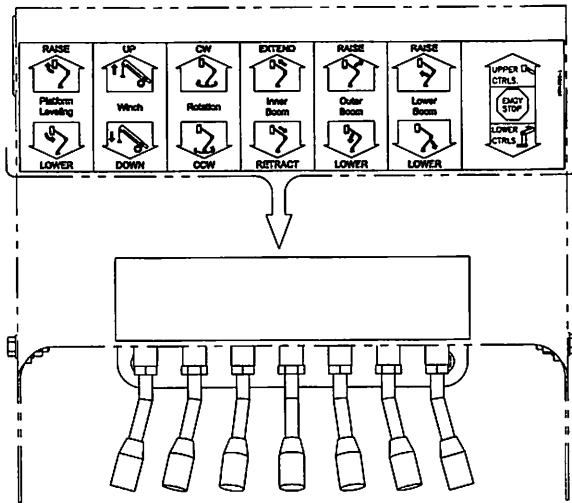

Lower Controls at Turret  
Figure 4.4

**ELECTRIC SELECTOR STATION** - The electric controls at the pedestal are arranged as shown in Figure 4.5. A description of each control and the method of operation is given below.

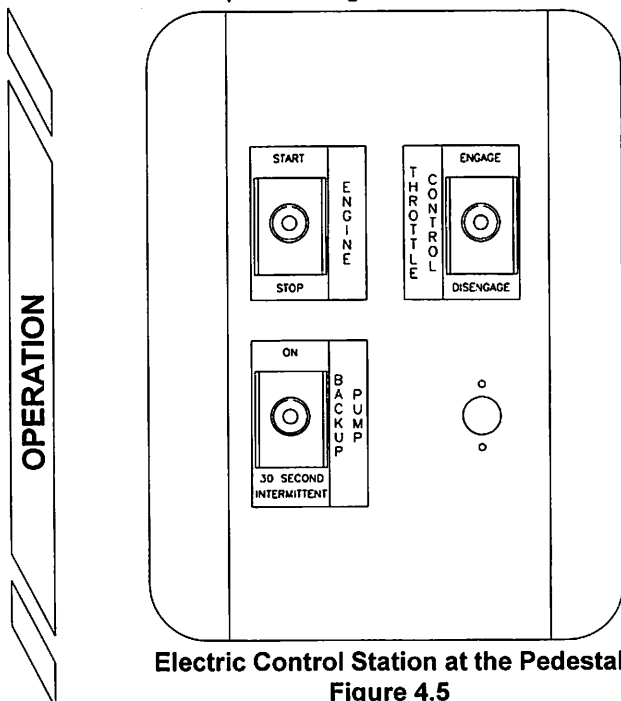

Electric Control Station at the Pedestal  
Figure 4.5

**ENGINE START/STOP CONTROL (Standard)** - The engine start/stop control is convenient for the ground crew at the pedestal. The engine start/stop control is operated by a three-position toggle switch.

To start the engine from the pedestal, push the toggle to the "START/STOP" position and hold the toggle in that position for a moment until the engine starts. Allow the toggle to return to the neutral or centered position.

To stop the engine from the pedestal, push the toggle to "START/STOP" again. Allow the toggle to return to the neutral or centered position. Refer to Section 5, "Emergency Operation" for information on the use of this control in an emergency.

**TWO-SPEED MANUAL THROTTLE CONTROL (Option)** - Gives the operator a choice of efficient, economical engine idle speed or higher engine speed when faster lift movements are required. The two-speed throttle control will operate only if the master control is activated. The two-speed throttle control is operated by a three-position toggle switch at the pedestal.

To speed up the engine from the pedestal, push the toggle to the "ENGAGE" position. Allow the toggle to return to the neutral or centered position.

To slow the engine to an idle from the pedestal, push the toggle to the "DISENGAGE" position. Allow the toggle to return to the centered or neutral position.

**BACKUP PUMP CONTROL (Option)** - If the aerial lift main power source fails, the backup pump option can be activated to operate the lift. The backup pump control is a detented toggle switch located at the pedestal. The backup pump system should not be operated longer than 30 seconds continuously. Continuous use will drain the battery and damage (over heat) the backup pump motor.

To activate the backup pump from the pedestal, push the toggle switch to the "ON" position and operate the appropriate lift controls.

To deactivate the backup pump from the pedestal, push the toggle switch down (towards the "30 SECOND INTERMITTENT" message).

**REMOTE CONTROLS (Optional)** - The hand-held remote control and remote lower control box are shown in Figure 4.6 and 4.7. The remote lower controls consist of a series of spring loaded toggle switches and a control selector switch. Moving the control switch in the direction of the arrow, with the control selector in the "lower" position, causes the aerial lift



to move in the corresponding direction. Lift movement stops as the control switch is released and returns to the neutral position.

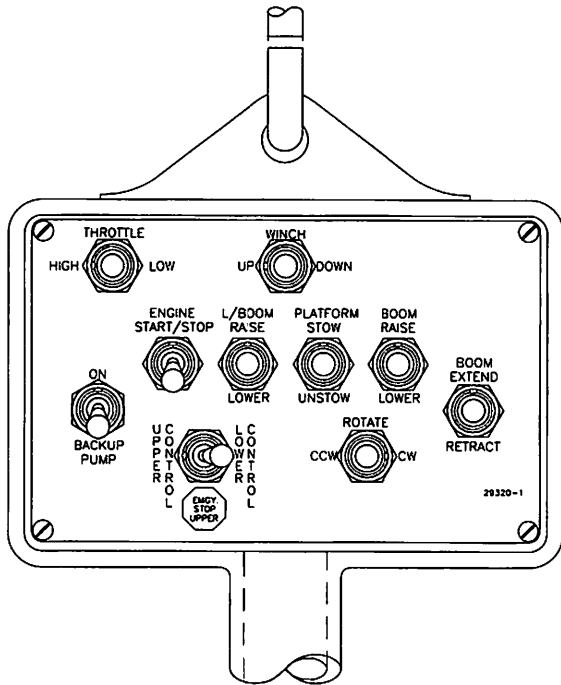

**Hand-Held Remote Control**  
Figure 4.6

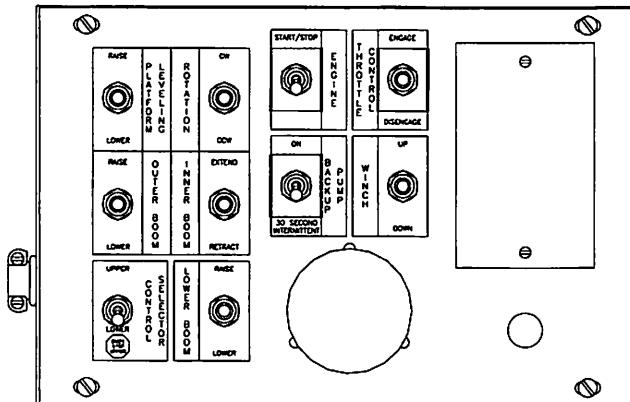

**Remote Control Box**  
Figure 4.7

## UPPER CONTROL OPERATION

This section describes the controls at the platform. The Unitrol standard 3-function or optional 4-function control is presented in this section. Never allow an untrained individual to operate the aerial lift.

**⚠ DANGER: AN UNTRAINED OR CARELESS OPERATOR SUBJECTS HIM/HERSELF AND OTHERS TO DEATH OR SERIOUS INJURY.**

When operating the lift, all lift movements must be started and stopped gradually.

**⚠ DANGER: NEVER REVERSE OR STOP THE DIRECTION OF THE LIFT TRAVEL SUDDENLY AND AVOID REACHING THE END OF THE BOOM TRAVEL AT EXCESSIVE SPEEDS. STRUCTURAL DAMAGE OR INSTABILITY MAY RESULT CAUSING DEATH OR SERIOUS INJURY.**

Never operate the upper controls without using the personnel restraint system.

**⚠ DANGER: NEVER OPERATE ANY AERIAL EQUIPMENT WITHOUT USING AN APPROVED PERSONNEL RESTRAINT SYSTEM ATTACHED TO THE SAFETY RING ON THE PLATFORM SUPPORT WELDMENT. FAILURE TO PROPERLY SECURE THE SAFETY BELT AND LANYARD MAY RESULT IN DEATH OR SERIOUS INJURY IN THE EVENT OF A FALL FROM THE PLATFORM.**

Before operating the aerial lift, the operator must be familiar with the built-in compensation link system that affects boom movements. The connecting components are shown on the "Major Components" drawing in Section 1. When the lower boom function is activated the lower boom will respond as directed and the upper boom will move and maintain its initial position in relation to the turret. However, activating the upper boom function will not affect the lower boom.

Speed and smoothness of lift operation are controlled by feathering the control valves. Feathering a control function allows the operator to change the speed by adjusting how far the control is moved. Flow can be directed to one function or multiple functions simultaneously. Function speed depends on flow to each valve. Regular practice will develop operator proficiency.

**UNITROL 3 OR 4-FUNCTION CONTROLS** - Refer to Figure 4.8 for clarification. This multi-jointed handle operates the valve spools and enables the operator

OPERATION



to control all lift movements.

Lift operations are selected by depressing the safety trigger while actuating the single stick control handle. Slowly move the single stick lever in the desired direction until motion begins. Further movement of the handle in the same direction will increase the speed of the motion. To stop a lift movement, move the single-stick lever back to the neutral position and release the trigger. Releasing the safety trigger in any position except neutral will cause the selector valve to slam shut and stop lift travel with an abrupt jerking motion resulting in unnecessary loads and stresses.

To operate two or more functions at the same time, position the single-stick handle anywhere in an area between the separate paths of the desired functions.

**EMERGENCY STOP (Standard)** - The primary purpose of the emergency stop valve is to deactivate all the upper controls in the event of a control valve malfunction (i.e. a valve spool stuck in the open position) or other hydraulic emergency. Push the knob labeled "PUSH FOR EMGY. STOP"; then the upper controls are inoperable and pressure at the tool ports is relieved. When the emergency stop knob is pulled up, the upper controls and tool power are functional.

**ENGINE START/STOP (Standard)** - The start/stop system has been designed so that the engine cannot be started unless the ignition switch is in the "RUN" position and the master control switch is activated. This feature makes it difficult for unauthorized individuals to operate the lift when the truck is locked. The engine start/stop system is operated by an air cylinder at the upper controls.

**⚠ DANGER: THE TRUCK TRANSMISSION MUST BE IN NEUTRAL BEFORE USING THE ENGINE START/STOP. STARTING THE TRUCK IN GEAR WILL CAUSE MOVEMENT WHICH MAY CAUSE DEATH OR SERIOUS INJURY TO THE OPERATOR IN THE LIFT OR ANYONE IN THE PATH OF THE TRUCK.**

To start the truck engine from the upper controls, push the air cylinder plunger knob down and hold the knob until the engine starts. If the truck starter does not engage, release the plunger knob and allow the plunger to rise to the neutral position. A second push on the plunger may be required to get the latching relay into position so the engine will start.

To stop the truck engine from the upper controls, push the air cylinder plunger knob down to get the latching relay into the stop position.

**HYDRAULIC PLATFORM LEVELING (Standard)** - Platform leveling is achieved with a master and slave cylinder arrangement. However, the hydraulic platform control at the platform and turret can be used to adjust platform leveling, tilt the platform for cleanout, or ease the removal of an injured operator.

**HYDRAULIC TOOL POWER (Standard)** - The hydraulic tool power ports are mounted outside the fiberglass guard that surrounds the upper controls. Always relieve the pressure to the tool ports before connecting or disconnecting the hydraulic tool hoses. To relieve the pressure, push the Tool Power Valve Knob in completely. Connect the hydraulic tool hoses to the tool ports (quick-disconnect outlets). Activate operating pressure to the hydraulic tools by pulling the Tool Power Valve Knob out.

**⚠ WARNING: FAILURE TO RELIEVE PRESSURE TO THE TOOL PORTS BEFORE CONNECTING OR DISCONNECTING THE HYDRAULIC TOOL HOSES MAY RESULT IN A HIGH PRESSURE HYDRAULIC OIL SPRAY. THIS SPRAY OR MIST CAN PUNCTURE AND BECOME EMBEDDED BENEATH THE SKIN OR CONTAMINATE THE EYES. THESE CONDITIONS REQUIRE IMMEDIATE MEDICAL ATTENTION.**

**HYDRAULIC PLATFORM ROTATION (Standard)** - The platform mount allows the platform to rotate 180°. To rotate, place the handle in the clockwise or counter-clockwise ("CW" or "CCW") position.

**TWO-SPEED MANUAL THROTTLE CONTROL (Option)** - The two-speed manual throttle control is operated by an air cylinder plunger knob at the upper controls. The two-speed control is designed to operate only if the engine is running and the master control is activated.

To speed up the engine from the upper controls, push the plunger knob down once and release it.

To slow the engine to an idle from the upper controls, push the plunger knob down and release it. It is recommended that the engine be left at idle until faster lift movements are required. This practice will provide efficient operation and minimize fuel consumption. During hydraulic tool operation the oil flow will be adequate to operate the tools at idle speed.

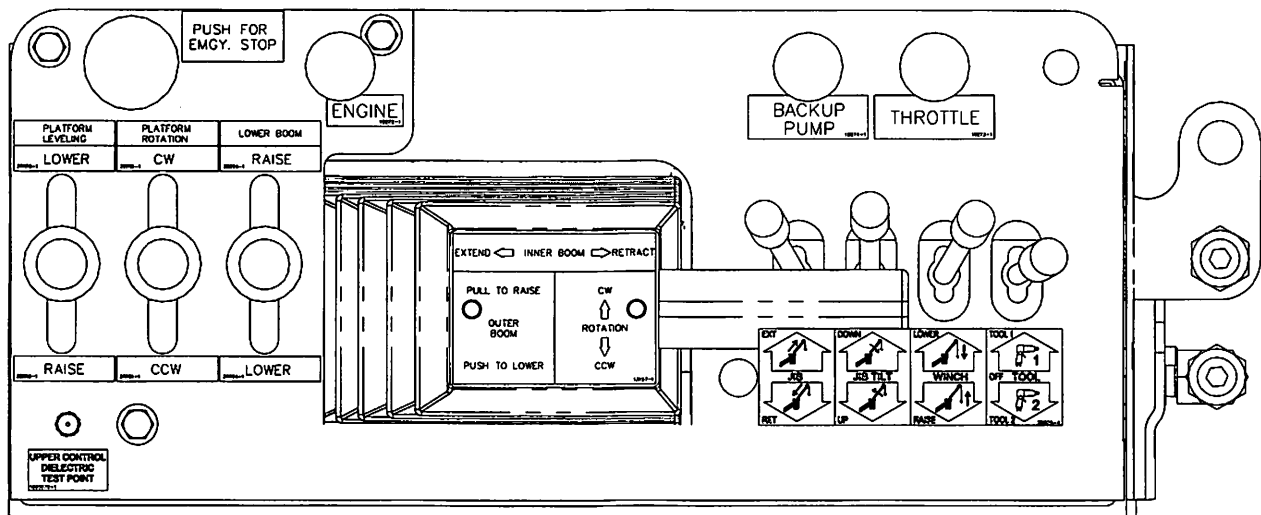

**3-Axis Upper Controls w/ Truguard  
(For Reference Only - Options May Vary)  
Figure 4.8**

**BACKUP PUMP CONTROL (Option)** - The backup pump system is operated by an air cylinder plunger knob. The backup pump system should not be operated longer than 30 seconds continuously. Continuous use will drain the battery and damage (over heat) the backup pump motor.

To activate this system from the upper controls, push the air cylinder plunger knob down and hold it while operating the lift controls.

To turn off the backup pump from the upper controls, release the air cylinder knob and allow it to return to the neutral position.

### STORING THE AERIAL LIFT

When storing the aerial lift for road travel retract the inner boom completely. Rotate the outer/inner boom assembly until it is centered over the boom rest. Rotate the platform so the bottom of the platform is centered over the platform support. Always stow the lower boom before descending the outer/inner boom assembly onto the boom rest. Release the outer/inner boom control lever as soon as there is firm contact with the boom rest pad. The platform will also contact the spring-loaded platform support.

**CAUTION:** FAILURE TO STOW THE LOWER BOOM BEFORE DESCENDING THE OUTER/INNER BOOM ASSEMBLY ON TO THE BOOM REST WILL STRESS THE COMPONENTS AND MAY CAUSE DAMAGE TO THE AERIAL LIFT.

**DANGER:** ALWAYS WATCH FOR PERSONNEL AND OBSTRUCTIONS WHEN STORING THE AERIAL LIFT. A CRUSHING INJURY TO PERSONNEL OR DAMAGE TO THE UNIT CAN OCCUR.

To complete the storing procedure secure the upper boom with the tie down strap, retract the outriggers, and remove the wheel chocks. Turn the electrical control system off and disengage the PTO pump drive.

**CAUTION:** TO PREVENT DAMAGE TO THE UNIT DO NOT DRIVE THE TRUCK UNTIL THE AERIAL LIFT IS STORED AND THE OUTER BOOM IS SECURED WITH THE BOOM TIE DOWN STRAP.

**CAUTION:** DRIVING WITH THE PTO ENGAGED MAY DAMAGE THE TRANSMISSION, PUMP, AND THE PTO.

**AUTO BOOM LATCH (optional)** – The automatic boom latch is designed to open automatically when the lift is operated. Stay clear of the latch as it may move at any time depending on the hydraulic system pressure.

**Manual over-ride** – In case of hydraulic system failure, the auto boom latch may be operated manually.

Over-ride Procedure:

1. **Danger** – Make sure the hydraulic power source is off.
2. Release the spring plunger by rotating the "T" handle.
3. Manually rotate the latch arm 90° clockwise until it snaps and is held by the spring plunger.

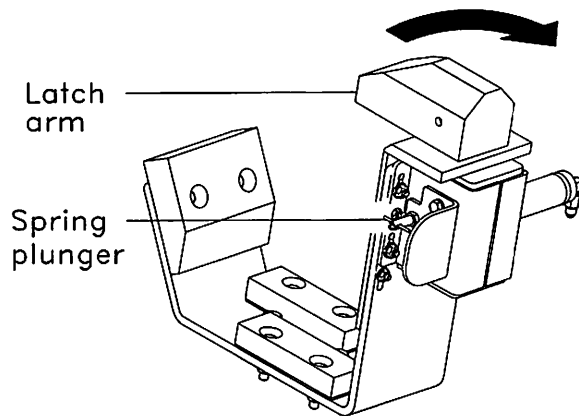

To Release Over-ride:

1. **Caution** – The latch is spring loaded. Keep fingers clear to prevent pinching.
2. Slightly rotate the latch arm clockwise to remove the load from the spring plunger.
3. While holding the latch arm, pull the spring plunger out and rotate the "T" handle to lock the spring plunger in the "out" position.
4. Carefully allow the latch arm to rotate counter-clockwise under spring power until it stops.

### LIFTING EYE (OPTION)

This aerial lift is designed primarily as a personnel lift. When tools or equipment are included with the operator in the platform the combined weight must not exceed the rated load capacity of the aerial lift.

**▲ DANGER: NEVER EXCEED THE RATED LOAD CAPACITY OF THE AERIAL LIFT. STRUCTURAL DAMAGE OR INSTABILITY MAY RESULT, CAUSING DEATH OR SERIOUS INJURY.**

The optional lifting eye has been designed to accommodate limited material handling. Always extend the outriggers (if so equipped) and fully retract the inner boom when using the boom lifting eye. Boom movements should be smooth to avoid swinging the load. Do not exceed the load limits stated on the decal beside the lifting eye. Do not drag the load with the lifting eye. This is a bad practice and subjects the unit to damaging sideloads. When lifting loads, position the lower boom directly over the load before lifting. The platform should be empty when lifting loads. When the truck is not level, extreme caution must be used when rotating loads toward the low side because the truck stability will be affected. **The platform must not be used for material handling.** The platform was designed to lift personnel only.

**▲ DANGER: INCREASING THE HORIZONTAL DISTANCE FROM THE TRUCK TO THE LOAD WILL REDUCE THE STABILITY OF THE TRUCK AND MAY RESULT IN DEATH OR SERIOUS INJURY.**

### MANUAL JIB OPERATION

The optional material handling system is designed to lift loads to the work site at the platform. The main components of this system are the sheave, winch line, jib pole, and the winch. The jib pole tilts and rotates manually. Although some of the components of the jib and winch are made from non-conductive materials, they are not tested or maintained as insulating. Therefore, the entire jib and winch assembly, including the jib pole and rope, must be considered conductive and have no insulating value.

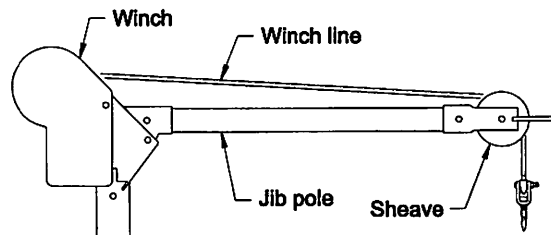

Manual Jib Major Components  
Figure 4.9

**▲ DANGER: DEATH OR SERIOUS INJURY MAY RESULT FROM MISUSE OR FAILURE CAUSED BY MISUSE OF THE AERIAL LIFT OR ITS COMPONENTS. BEFORE OPERATION, KNOW THE INSTRUCTIONS AND LIMITATIONS OF THE LIFT AND THE MATERIAL HANDLING SYSTEM.**



**⚠ DANGER:** DO NOT DEPEND ON THE JIB POLE FOR INSULATION UNLESS THE POLE HAS BEEN RATED, TESTED, AND MAINTAINED FOR THE APPROPRIATE LINE VOLTAGE. THE WINCH ROPE IS NOT CONSIDERED INSULATING. IMPROPER USE OF THE JIB POLE OR WINCH ROPE MAY RESULT IN DEATH OF SERIOUS INJURY.

**Jib Pole Tilt Angle** - The jib pole can be manually tilted into one of six positions. To adjust the jib pole, follow the sequence below:

1. Remove any load from the jib and winch assembly. Never attempt to adjust the jib while under load.
2. Remove the jib tilt lock pin.
3. Tilt the jib to the desired position.
4. Fully replace the lock pin.

**Jib Rotation** - The jib pole assembly can be rotated to one of three different positions to accommodate a load. These load lifting positions are located at 0° and 30° to either side of the boom. See Figure 4.10. To rotate the jib assembly, follow the sequence below:

1. Remove any load from the jib and winch assembly. Never attempt to rotate the jib while under load.
2. Remove the jib rotation lock pin.
3. Rotate the jib to the desired position.
4. Fully replace the lock pin

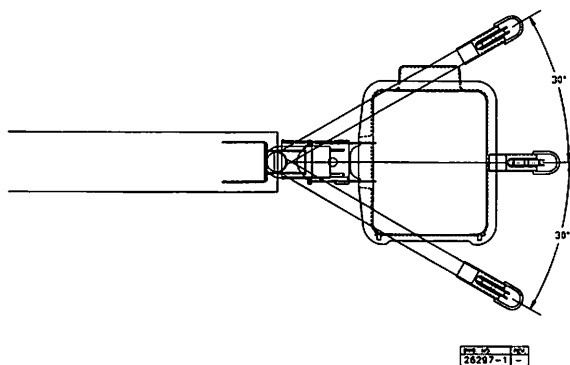

**Jib-Pole Assembly Rotation Positions**  
Figure 4.10

**⚠ DANGER:** ALL JIB POLE POSITIONING ADJUSTMENTS MUST BE MADE BEFORE ENGAGING A LOAD. ADJUSTMENT OF THE ASSEMBLY WITH A LOAD MAY CAUSE DEATH OR INJURY TO THE OPERATOR AND DAMAGE TO THE EQUIPMENT.

**⚠ DANGER:** NEVER OPERATE THE JIB POLE ASSEMBLY UNTIL THE ASSEMBLY TURRET IS LOCKED IN A LOAD LIFTING POSITION AND THE VARIOUS LOCK PINS ARE SECURE. A LOAD SHIFT CAN CRUSH THE OPERATOR AND CAUSE DEATH OR SERIOUS INJURY.

**HYDRAULIC WINCH OPERATION** - This control is located in the boom control panel mounted to the platform. To operate, move the appropriate lever in the direction indicated on the decal. The winch control is also duplicated at the lower controls for use in case of an emergency. When operating from the lower controls, the winch speed will be slower.

**⚠ DANGER:** IF THE WINCH ROPE HAS ABRASIVE WEAR, PULLED STRANDS, CUTS, HEAT DAMAGE, OR OTHER DEFECTS, IT MUST BE REPLACED BEFORE FURTHER USE. THE RECOIL FROM ROPE FAILURE OR FALLING OBJECTS CAN CAUSE DEATH OR SERIOUS INJURY TO THE OPERATOR OR GROUND CREW.

**⚠ DANGER:** PHASE-TO-PHASE OR PHASE-TO-GROUND CONTACT OF THE WINCH LINE WILL REDUCE THE STRENGTH OF THE ROPE. THE RECOIL FROM ROPE FAILURE OR FALLING OBJECTS CAN CAUSE DEATH OR SERIOUS INJURY TO THE OPERATOR OR GROUND CREW.

**⚠ DANGER:** NEVER RAISE A LOAD UNLESS IT IS SECURELY FASTENED. DO NOT USE THE WINCH LINE TO WRAP OR TIE AN OBJECT FOR LIFTING BECAUSE THE HOOK ON THE WINCH LINE MAY DAMAGE OR CUT THE ROPE. THE RECOIL FROM ROPE FAILURE OR FALLING OBJECTS CAN CAUSE DEATH OR SERIOUS INJURY TO THE OPERATOR OR GROUND CREW.

**⚠ DANGER:** NEVER USE THE WINCH TO RAISE PERSONNEL OFF THE GROUND. A FALL MAY RESULT IN DEATH OR SERIOUS INJURY.

**⚠ DANGER:** DO NOT, UNDER ANY CIRCUMSTANCE, STAND BELOW A SUSPENDED LOAD. DEATH OR SERIOUS INJURY MAY OCCUR



**IF PERSONNEL ARE STRUCK BY FALLING OBJECTS.**

**⚠ DANGER: CONTACT BETWEEN AN ENERGIZED CONDUCTOR AND A WINCH ROPE EXTENDED TO THE GROUND OR ANOTHER CONDUCTOR MAY COMPLETE A PATH FOR ELECTRICITY AND CAUSE DEATH OR SERIOUS INJURY TO THE OPERATOR OR GROUND CREW.**

**⚠ DANGER: BEFORE OPERATION INSPECT FOR LOOSE WINCH MOUNTING BOLTS. IF LOOSENING OCCURS HAVE THE UNIT SERVICED AND REPLACE THESE CRITICAL BOLTS BEFORE FURTHER USE. USE OF A LOOSE WINCH OR BROKEN COMPONENTS MAY CAUSE THE EQUIPMENT TO BREAK LOOSE AND RESULT IN DEATH OR SERIOUS INJURY TO THE OPERATOR OR GROUND CREW.**

**⚠ DANGER: MAKE CERTAIN THE WINCH-ROPE COILS ARE SPOOLING EVENLY TO AVOID CLOGGING THE WINCH OR PRODUCING SHOCK LOADS. AVOID SHOCK LOADS CAUSED BY JERKING A LINE WITH A LOAD OR SUDDEN CHANGE IN TENSION FROM A LIGHT TO A HEAVY LOAD. SHOCK LOADS MAY CAUSE STRUCTURAL DAMAGE OR INSTABILITY RESULTING IN DEATH OR SERIOUS INJURY.**

**⚠ DANGER: THERE MUST BE AT LEAST 5 COILS OF ROPE WOUND ON THE WINCH REEL AT ALL TIMES BECAUSE THE WINCH DRUM AND ROPE ATTACHMENT ARE NOT DESIGNED FOR FULL ROPE EXTENSION. THE RECOIL FROM ROPE DETACHMENT OR FALLING OBJECTS CAN CAUSE DEATH OR SERIOUS INJURY TO THE OPERATOR OR GROUND CREW.**

OPERATION

## HYDRAULIC JIB OPERATION

The optional material handling system is designed to lift loads to the work site at the platform. The main components of this system are the sheave, winch line, jib pole, and the winch. The jib pole tilts and extends hydraulically, and rotates manually. Although some of the components of the jib and winch are made from non-conductive materials, they are not tested or

maintained as insulating. Therefore, the entire jib and winch assembly, including the jib pole and rope, must be considered conductive and have no insulating value.

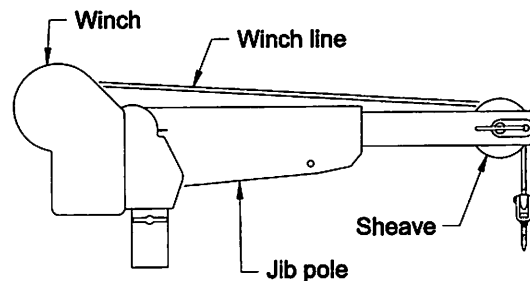

**Hydraulic Jib Major Components  
Figure 4.11**

**Hydraulic Tilt, Extend, And Winch Operation -** Controls for these functions are located in the upper control panel mounted to the platform. To operate, move the appropriate lever in the direction indicated on the decal. The winch control is also duplicated at the lower controls for use in case of an emergency. When operating from the lower controls, the winch speed will be slower.

**Jib Rotation -** The jib pole assembly can be rotated to one of eight different positions to accommodate a load. These load lifting positions are located at 0° and 30° to either side of the boom. See Figure 4.10.

1. Remove any load from the jib and winch assembly. Never attempt to rotate the jib while under load.
2. Remove the jib rotation lock pin.
3. Rotate the jib to the desired position.
4. Fully replace the lock pin.

## JIB CAPACITY DETERMINATION (VST-36/40/47-I)

The lifting capacity of the material handling system is conditional and depends on the angle of the jib pole, the extension of the inner boom, and the angle of the outer boom. To determine the lifting capacity of the jib at a particular position, refer to the procedure and example below. The capacities shown here are for example only. Refer to the decals on the unit for the actual lifting capacities.

**⚠ DANGER: NEVER EXCEED THE MAXIMUM LIFTING CAPACITY AS SHOWN BY THE MATERIAL HANDLING LOAD CHART. OVERLOADING THE LIFT MAY CAUSE EQUIPMENT FAILURE RESULTING IN DEATH OR SERIOUS INJURY.**

**⚠ DANGER: EXCEEDING THE MAXIMUM LIFTING CAPACITY OF THE LIFT OR THE JIB MAY CAUSE EQUIPMENT FAILURE RESULTING IN DEATH OR SERIOUS INJURY.**

Jib Capacity Component Description - The inner boom is color coded. A green stripe aligns with the end of the outer boom to indicate when the inner boom is fully retracted. The inner boom is painted white from 0 to 36 inches of extension. After 36 inches, the exterior of the inner boom is painted red.

The inner boom is equipped with a pointer and jib capacity decal. The pointer responds to gravity, so as the boom angle changes, the pointer tracks to different areas of the decal. The decal is divided in to three zones - one green, one white, and one red.

The jib pole is equipped with a maximum capacity decal near the pivot.

**Procedure to Determine the Jib Capacity:**

1. Determine the color of the inner boom where it exits the outer boom. It will be green, white, or red.
2. Read the capacity from the inner boom pointer. If the boom in step 1 was green, read the capacity from the green portion of the decal. If the boom in step 1 was white, read the capacity from the white portion of the decal. If the boom in step 1 was red, read the capacity from the red portion of the decal.
3. Check the capacity of the jib pole by reading the decal near the jib pole tilt pivot.
4. The actual lifting capacity is the smaller of the two capacities determined in steps 2 and 3.

Example – See Figure 4.12

1. In this example, the inner boom is red where it exits the outer boom.
2. Reading the red zone, the inner boom pointer indicates 300 lbs capacity.
3. The jib pole tilt decal reads 500 lbs.
4. The actual lifting capacity is the smaller of the two capacities determined in steps 2 and 3. So, the actual capacity is 300 lbs.

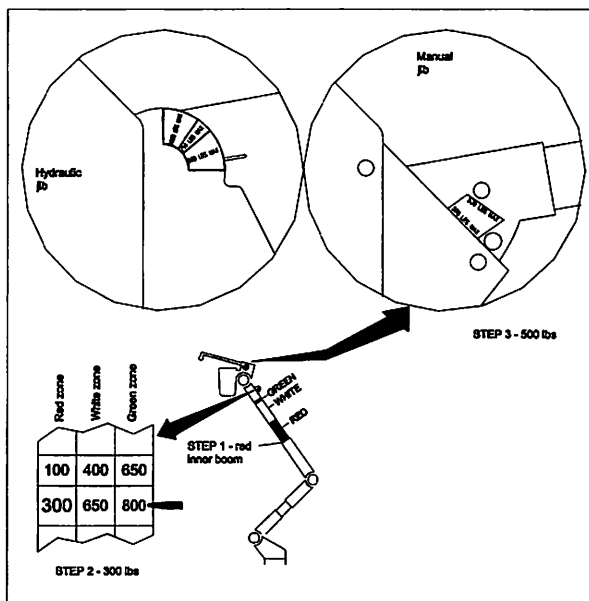

**VST-36/40/47-I Jib Capacity Determination Figure 4.12**

OPERATION

**JIB CAPACITY DETERMINATION (VST-52-I Only)**

The lifting capacity of the material handling system is conditional and depends on the angle of the jib pole, the extension of the inner boom, and the angle of the outer boom. Also, the lower boom must be partially raised to allow material handling. To determine the lifting capacity of the jib at a particular position, refer to the procedure and example below. The capacities shown here are for example only. Refer to the decals on the unit for the actual lifting capacities.

**⚠ DANGER: NEVER EXCEED THE MAXIMUM LIFTING CAPACITY AS SHOWN BY THE MATERIAL HANDLING LOAD CHART. OVERLOADING THE LIFT MAY CAUSE EQUIPMENT FAILURE RESULTING IN DEATH OR SERIOUS INJURY.**

**⚠ DANGER: EXCEEDING THE MAXIMUM LIFTING CAPACITY OF THE LIFT OR THE JIB MAY CAUSE EQUIPMENT FAILURE RESULTING IN DEATH OR SERIOUS INJURY.**

Jib Capacity Component Description - The inner boom is color coded. A green stripe aligns with the end of the outer boom to indicate when the inner boom is



fully retracted. The remainder of the inner boom is painted white.

The inner boom is equipped with a pointer and jib capacity decal. The pointer responds to gravity, so as the boom angle changes, the pointer tracks to different areas of the decal. The decal is divided in to two zones - one green, and one white.

The jib pole is equipped with a maximum capacity decal near the pivot.

The lower boom is equipped with a pointer and color coded decal. The pointer responds to gravity, so as the lower boom angle changes, the pointer tracks to different areas of the decal. The decal is divided in to two zones - one white, and one red. The pointer must be in the white zone to use the material handling system. When the pointer is in the red zone, the material handling capacity is zero.

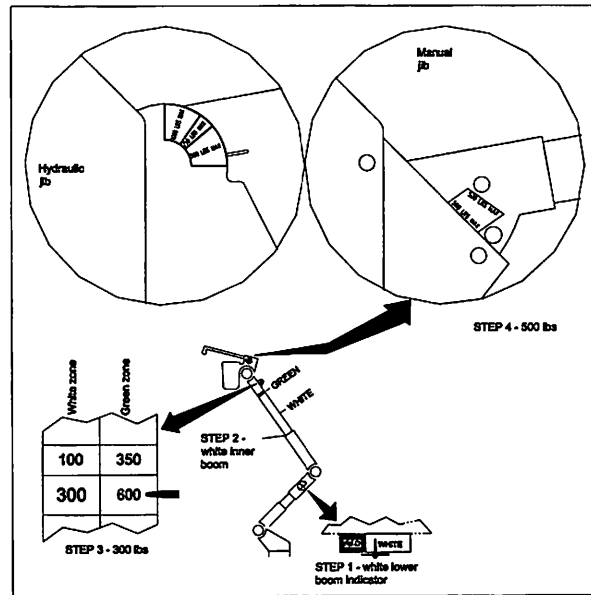

VST-52-I Jib Capacity Determination  
Figure 4.13

**Procedure to Determine the Jib Capacity:**

1. Check the color of the lower boom angle indicator. It must be in the white zone to use the material handling system.
2. Determine the color of the inner boom where it exits the outer boom. It will be green or white.
3. Read the capacity from the inner boom pointer. If the boom in step 2 was green, read the capacity from the green portion of the decal. If the boom in step 2 was white, read the capacity from the white portion of the decal.
4. Check the capacity of the jib pole by reading the decal near the jib pole tilt pivot.
5. The actual lifting capacity is the smaller of the two capacities determined in steps 3 and 4.

Example – See Figure 4.13

1. In this example, the lower boom angle indicator is white, so material handling is allowed.
2. The inner boom is white where it exits the outer boom.
3. Reading the white zone, the inner boom pointer indicates 300 lbs capacity.
4. The jib pole tilt decal reads 500 lbs.
5. The actual lifting capacity is the smaller of the two capacities determined in steps 3 and 4. So, the actual capacity is 300 lbs.

OPERATION





# EMERGENCY OPERATION

Emergency operation may be required if an operator is injured or the hydraulic system malfunctions. This chapter describes the controls and features designed to accommodate emergency operation and to describe some procedures for responding to emergency situations. In an emergency, the first priority is always the safety of the personnel. Before attempts are made to rescue personnel, make sure the unit has not become electrically energized. Identifying the problem and initiating emergency procedures promptly helps minimize or possibly prevents injuries. It is important to follow standard work practices and safety regulations.

**⚠ DANGER:** *BEFORE ATTEMPTING TO RESCUE PERSONNEL ON THE AERIAL LIFT, ALWAYS MAKE SURE THAT THE TRUCK AND THE AERIAL LIFT HAVE NOT BECOME ELECTRICALLY ENERGIZED. CONTACT MADE BY RESCUERS FROM THE GROUND WITH AN ENERGIZED UNIT WILL CAUSE DEATH OR SERIOUS INJURY.*

**CONTROL SELECTOR (Platform Override)** - If a situation requires overriding the upper controls (i.e. an injured operator in the platform), use the selector control at the turret to transfer control to the lower controls. The upper controls will not be operable and the lower controls can be used to lower the operator to the ground. Refer to lower controls paragraph in Section 4, Operation, of this manual.

**BLEEDER PORTS** - If the hydraulic system becomes inoperable with an operator aloft, bleeder ports on the cylinders (Figures 5.2, 5.3, and 5.4) can be used to lower the booms and return the operator to the ground. Qualified personnel at the site are responsible for selecting the path of boom decent. The unit may be equipped with two different type of bleeder ports. Refer to Figure 5.1 for identification and proper procedures for loosening the bleeder ports. Be prepared for a flow of hot oil escaping around the bleeder port and step away from the boom path of descent. The speed at which the lower boom drifts down depends on the rate of oil loss.

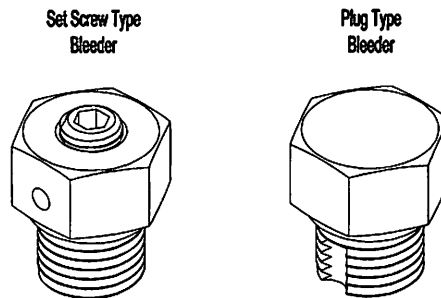

**Bleeder Ports**  
Figure 5.1

**Set Screw Type Bleeder** - Turn the set screw slowly using an Allen wrench to release load. Do not turn the body. Oil is released from the hole on the side of hex body.

**Plug Type Bleeder** - Turn the entire plug slowly using a wrench to release load. Do not remove the plug. Oil is released from the notch in the threads. Torque to 12-15 ft-lbs. after use.

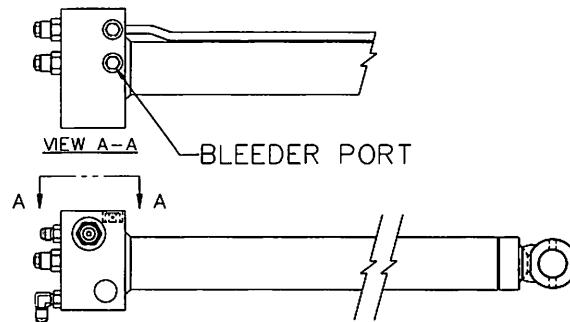

**Extension Cylinder Bleeder Port**  
Figure 5.2

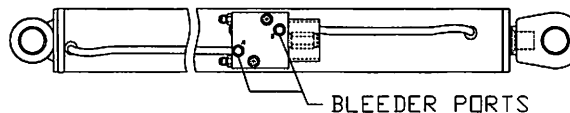

**Upper Cylinder Bleeder Ports**  
Figure 5.3

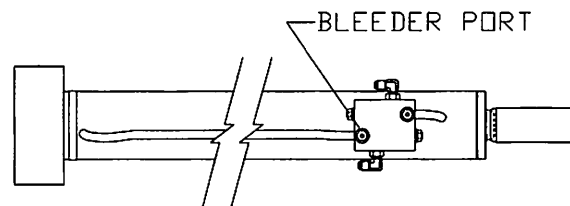

**Lower Boom Cylinder Bleeder Port**  
Figure 5.4

EMERGENCY OPERATION

**MANUAL ROTATION** - The rotation system can be operated manually if the hydraulic system becomes inoperable. Before manual rotation is attempted remove the plugs from the motor test ports on the dual counter-balance valve manifold located on the rotation motor (Figure 5.5). This allows oil to be piloted during rotation of the lift. Be prepared for a flow of oil escaping from the motor test ports. Rotate the lift using a 7/8 in. hex socket and ratchet to turn the input shaft on the gearbox (Figure 5.6). Actuating the lower rotation control lever will reduce the effort required to rotate the lift.

If manual rotation is used, test port plugs must be replaced on counter-balance valve manifold. See "Responsibilities after Emergency Operation" at the end of this chapter.

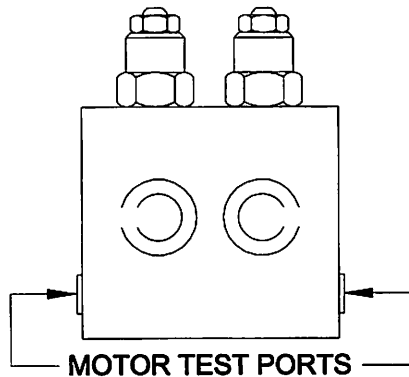

Test Port Plugs  
Figure 5.5

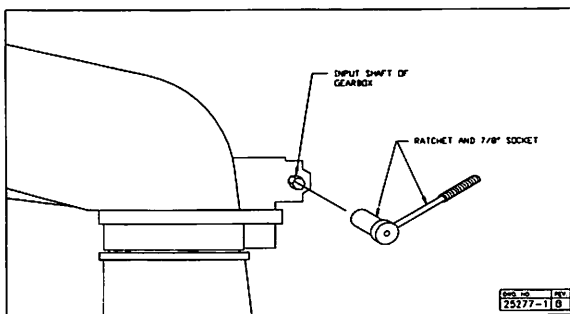

Manual Rotation  
Figure 5.6

**OUTRIGGER BOOM INTERLOCK MANUAL OVERRIDE** – In the event of diverter valve failure, and the lift becomes inoperable with an operator aloft, the outrigger boom interlock selector can be overridden to lower the booms and return the operator to the ground. To activate the manual override, locate the solenoid operated 3-way valve, usually in the pedestal. On the end of the valve, there

is a small tab (Fig. A) which can be pressed with a small screwdriver, capscrew, etc. With this tab pressed down, hydraulic flow will be diverted from the outriggers to the lift. Another operator can then operate the lower controls to lower the booms.

**WARNING: USE OF MANUAL OVERRIDE TO OPERATE THE LIFT WITHOUT THE OUTRIGGERS DEPLOYED CAN RESULT IN SERIOUS INJURY OR DEATH.**

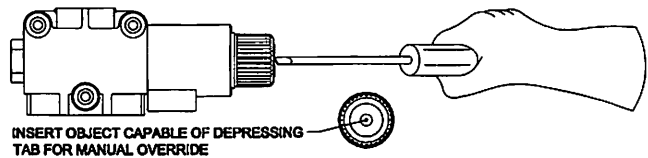

OUTRIGGER BOOM INTERLOCK SELECTOR VALVE MANUAL OVERRIDE ON SOLENOID OPERATED 3-WAY VALVE

Figure A

Outrigger Boom Interlock Manual Rotation  
Figure 5.7

**BACKUP PUMP (Option)** - The backup pump system provides hydraulic power from a DC pump-motor for emergency operation of the lift in the event of a prime power source failure.

The backup pump system should not be operated longer than 30 seconds continuously. Continuous use will drain the battery and damage (over heat) the backup pump motor.

*At the upper controls*, the backup pump is operated by an air cylinder. To activate this system, push the air cylinder plunger knob and hold it while operating the upper control. To turn off the backup pump, release the plunger knob and allow it to return to the neutral position.

*At the lower controls*, the backup pump is operated by a detented toggle switch. To activate this system, move the toggle to the "ON" position and operate the appropriate control levers. To turn off the backup pump, return the toggle switch to the "STOP" position.

**ENGINE START/STOP CONTROL** - The engine start/stop control can be used for emergency operation if the truck engine (PTO models) or the generator engine will not stay running. Operate the aerial lift only while attempting to lower the booms. To conserve the battery and prevent damage to the starter, do not crank the engine for more than 30 seconds continuously. The engine start/stop control at the upper or lower controls may be

EMERGENCY OPERATION



used while actuating the lift function.

**At the upper controls**, the engine start/stop control is operated by an air cylinder. The air cylinder plunger knob is pushed down and held until the engine starts. The plunger knob may require a second push to set the latching relay into the start position. Another push on the plunger knob will stop the engine.

**At the lower controls**, the engine start/stop system is operated by momentary toggle switch. This system is activated by pushing the switch to the "START/STOP" position. It may require a second push to set the latching relay in the start position. To stop the engine push the switch to the "START/STOP" position once more.

**INJURED OR INCAPACITATED OPERATOR** - If the operator is unable to operate the aerial lift, determine if any damage has occurred to make the lift inoperable. If the aerial lift is operable and the situation allows safe operation from the lower controls, move the platform away from the danger and into the safest clear path of descent to get the operator on the ground. See "Control Selector", at the beginning of this chapter, for specific instructions on overriding the upper controls. If the aerial lift is not operable, use another aerial lift to rescue the operator from the platform or consider one of the other emergency procedures in this chapter.

**HYDRAULIC LINE FAILURE** - Hydraulic line failure during aerial lift operation presents numerous hazards. Be aware that hydraulic oil mist caused by a leak or hydraulic line failure is conductive even though a non-conductive oil is used.

**! DANGER: AVOID HIGH PRESSURE HYDRAULIC OIL SPRAY. THIS SPRAY OR MIST CAN PUNCTURE AND BECOME EMBEDDED BENEATH THE SKIN OR CONTAMINATE THE EYES. THESE CONDITIONS REQUIRE IMMEDIATE MEDICAL ATTENTION.**

A hydraulic line leak will create a slippery surface which is potentially hazardous. When a hydraulic leak is encountered it must be repaired by the proper service personnel and the unit should be cleaned of excess hydraulic oil. If a hydraulic leak is not repaired the oil in the reservoir will be depleted and pump damage may occur. Most hydraulic oils are flammable and bodily contact with hot oil is dangerous. The operator and the ground crew must be alert for these hazards to avoid injury.

**! DANGER: AVOID ANY CONTACT BETWEEN HYDRAULIC OIL AND SOURCES OF HIGH HEAT OR OPEN FLAMES. DEATH OR SERIOUS INJURY MAY RESULT FROM A FIRE.**

**! WARNING: CONTACT WITH HOT HYDRAULIC OIL MAY CAUSE SERIOUS BURNS WHICH REQUIRE IMMEDIATE MEDICAL ATTENTION.**

A quick response to hydraulic line failure is important if the operator is to be safely removed from the platform. A quick response can simplify the steps required to lower the platform and remove the operator. The following examples describe some emergency operating procedure for typical hydraulic line failures.

1. The Versalift aerial lift design uses holding valves to lock the booms in position in the event of a hydraulic line failure. If there is a continuous loss of hydraulic oil from the aerial lift, operate the hydraulic power source only while attempting to stow the aerial lift to conserve the hydraulic oil supply. If operation of the aerial lift is impossible, use the bleeder ports and manual rotation.
2. A hydraulic line failure located between the upper and lower controls may temporarily allow the continued operation of the aerial lift. The rate of the hydraulic oil loss can be reduced by overriding the upper controls and operating the aerial lift with the lower controls. If the oil supply is depleted, discontinue operation of the hydraulic power source to avoid damage to the hydraulic pump. If the aerial lift is inoperable, use the bleeder ports and manual rotation.

**ENGINE FAILURE** - If the prime power source fails, the optional backup pump system can be used for emergency operation. If this system is not installed, use the engine start/stop control to crank the engine, as previously explained. The bleeder ports and manual rotation must be used if these systems are not installed.

**HYDRAULIC PUMP FAILURE** - If the primary hydraulic pump fails use the backup pump system (if equipped) or the bleeder ports and manual rotation.



**CONTROL VALVE FAILURE** - If aerial lift motion cannot be stopped use the emergency stop, upper control override, or engine start/stop control to halt the lift functions.

**Upper Control** - Push the knob labeled "PUSH FOR EMGY. STOP". When the emergency stop knob is pushed down, the upper controls are inoperable and pressure at the tool ports is relieved.

**Lower Controls** - The aerial lift may be operated by overriding the upper controls with the control selector.

**Engine Start/Stop Control** - The engine start/stop control, at the upper, lower, or cab controls, can be used to stop the engine and hydraulic flow to the lift functions.

#### **RESPONSIBILITIES AFTER EMERGENCY OPERATION:**

After any emergency situation it is the responsibility of the operator to make sure the aerial lift is repaired and adjusted by the service department before it is used again.

If an equipment defect is suspected, do **not** allow anyone to operate the aerial lift or enter the platform.

If the bleeder ports are used they must be retightened and the hydraulic reservoir must be refilled. The aerial lift must then be operated, from the lower controls, through its full range of motion several times. Check the hydraulic oil reservoir level and refill if necessary.

EMERGENCY OPERATION

## DAILY VISUAL INSPECTION

This aerial lift is designed to provide years of reliable service with minimum maintenance. A routine preventive maintenance program will assure extended aerial lift service. The operator is responsible for detecting maintenance problems during the daily visual inspection, reporting the need for adjustments or repairs, verifying that maintenance is performed at the suggested intervals, and determining if the aerial lift is in a good, safe operating condition. The importance of accurate maintenance records cannot be over emphasized. In order to judge the condition of the aerial lift, the operator needs to be familiar with the maintenance records of the aerial lift. Refer to the "Maintenance Checklist" in Service Procedures Section of the Service Manual for the suggested interval inspection information. The actual repair or adjustment must be done by a qualified aerial lift mechanic.

Every day the equipment must be given a thorough visual inspection to detect problems before they become serious. During this inspection the operator shall look for anything out of the ordinary that might indicate a problem. Particular attention must be paid to the following items. The Daily Visual Inspection Checklist included in this section must be followed.

**BOLTS** - Critical fasteners are identified on the "Critical Fasteners" drawing in this section. All major sections of the Versalift are bolted together and it is vital that these bolts remain tight. Visually inspect all the bolts for signs of relative movement. Pay particular attention to the load supporting bolts (rotation bearing bolts, pedestal/subframe mounting bolts, platform rotator bolts). Critical bolts are Torque-Seal marked to provide a quick means of detecting any turning. Do not use the lift if the Torque-Seal mark between the bolt head and mounting surface, are not in alignment. Refer to Maintenance and Inspection Schedule in Service Procedures Section of the Service Manual for recommended torque procedures and torque chart specifications. Refer to Figure 6.1 and 6.2 for Torque-Seal mark conditions.

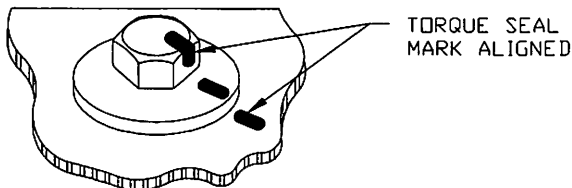

**Torque-Seal Mark In Acceptable Condition**  
Figure 6.1

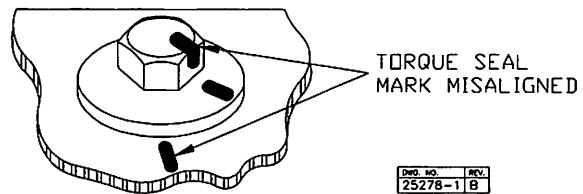

**Torque-Seal Mark In Misalignment Condition**  
Figure 6.2

**WELDS** - Refer to the "Critical Welds" drawing in this section. All the welds should be inspected for signs of fatigue. Rust and hairline cracks on a weld indicate weld fatigue.

**HYDRAULIC LINES** - Hydraulic lines should be inspected for loose connections and frayed jackets. Carefully examine the hoses, especially any portion of hose subject to flexing and particularly the hoses at the platform.

**OIL LEAKS** - Oil leaking onto the truck floor or the ground is sign of an impending problem. A hydraulic leak will create a slippery surface which is potentially hazardous. Hydraulic leaks must be repaired by qualified service personnel and the unit must be cleaned of excess hydraulic oil. If a hydraulic leak is not repaired the oil in the reservoir will be depleted and pump damage may occur.

**ELECTRICAL SYSTEM** - Inspect electrical system for damaged components. Check for bare electrical wires and remove any trash or debris from around electrical components. Repair all damaged wires and secure any loose electrical components or wires.

**VEHICLE TIRES** - Check tires for the correct inflation and for damage. Low pressure or damaged tires are unsafe while driving the vehicle or operating the lift.

**LOOSE OBJECTS** - Inspect the booms for loose objects (tools, spare parts, etc.) that might fall when the booms are elevated.

**HYDRAULIC OIL LEVEL** - The hydraulic fluid level can be easily checked by monitoring the oil level through the sight gages. The two sight gages are mounted, one several inches above the other, on the pedestal. The hydraulic oil level should be just above the bottom of the top sight gage at full capacity (17 gallons or 64.4 liters)

**CONTROLS** - Operate all the lift controls through the full range of motion to verify the controls are functioning properly.

**EXTENSION SYSTEM** - While operating the unit from the lower controls, observe the extension system during operation. First, raise the outer/inner boom assembly to a maximum upright position, and then fully extend the inner boom. Next, lower the outer/inner boom assembly to a position slightly below horizontal, and then retract the inner boom. Extension and retraction of the inner boom should be smooth. Also, listen for any abnormal noises while extending and retracting, which could indicate a potential problem and warrant further inspection of the extension system.

**LEVELING SYSTEM** - Inspect the master cylinder, slave cylinder, hoses, and fittings for damage, wear, or foreign objects which may prevent proper operation. Refer to Parts & Assemblies Section of the Service Manual for these components. Also inspect the protective fiberglass covers, on each side of the slave cylinder, for cracks or damage. If these conditions exist they must be repaired by qualified personnel before operation.

**DECALS** - Identification, operational, and instructional decals are installed at numerous locations on the **Versalift**. These decals must be replaced if they become lost, damaged, or illegible. Refer to the "Decal Placement" illustration in this section.

**ROPE** - Make a thorough check of the winch rope for abrasive wear, pulled strands, cuts, and other defects. The rope should be clean and dry. The rope coils should spool evenly on the winch reel. Do not use a rope that has been subjected to shock loads. Replace the winch rope at the first sign of damage or deterioration. Use only non-conductive rope of the size and type specified.

**WINCH** - Verify that the rope coils are spooling evenly. Check for hydraulic leaks as well as leaks from the winch drive gearbox.

**FIBERGLASS BOOMS** - Inspect the fiberglass upper boom and the lower boom for an accumulation of dirt that can impair the insulating value of the fiberglass. The fiberglass outer surface of the booms should be cleaned daily with a lint free cloth. If the fiberglass sections require a more thorough cleaning, Refer to Service Procedures Section, "Care of Fiberglass Booms", of the Service and Installation Manual. Check for any structural damage in the fiberglass, such as cracks or gouges. If these conditions exist, they must be repaired by qualified personnel.

**PLATFORM** - Inspect the platform for cracks in the mounting ribs, floor, and flange around the top. If

these conditions exist they must be repaired by qualified personnel before operation.

**SLOPE INDICATORS** - The indicators are installed at several locations on the Versalift chassis. Check that indicators are in place and not damaged. Refer to slope indicator installation in the Service Manual.

**SAFETY DEVICES** - Check visual and audible safety devices for proper operation.

**COVERS** - Inspect all covers to make sure they are in place, secure, and in good condition.

**DAILY VISUAL MAINTENANCE AND INSPECTION CHECKLIST AND RECORD**  
**VERSALIFT VST-36/40/47/52-I SERIAL NO. \_\_\_\_\_ VEHICLE NO. \_\_\_\_\_**

Fill in date and initial boxes when each check is made. Refer to Daily Visual Inspection in this section for complete description of checks. Additional copies of this form may be obtained from **Time Manufacturing Company**.

| DAY                              | SUN | MON | TUE | WED | THU | FRI | SAT |
|----------------------------------|-----|-----|-----|-----|-----|-----|-----|
| DATE                             |     |     |     |     |     |     |     |
| INSPECT BOOMS FOR TRASH & DEBRIS |     |     |     |     |     |     |     |
| CRITICAL FASTENERS               |     |     |     |     |     |     |     |
| CRITICAL WELDS                   |     |     |     |     |     |     |     |
| HYDRAULIC LINES - FRAYED JACKETS |     |     |     |     |     |     |     |
| OIL LEAKS - LOOSE CONNECTIONS    |     |     |     |     |     |     |     |
| ELECTRICAL SYSTEM                |     |     |     |     |     |     |     |
| VEHICLE TIRES                    |     |     |     |     |     |     |     |
| LOOSE OBJECTS                    |     |     |     |     |     |     |     |
| HYDRAULIC OIL LEVEL              |     |     |     |     |     |     |     |
| CONTROLS                         |     |     |     |     |     |     |     |
| EXTENSION SYSTEM                 |     |     |     |     |     |     |     |
| LEVELING SYSTEM                  |     |     |     |     |     |     |     |
| DECALS                           |     |     |     |     |     |     |     |
| ROPE                             |     |     |     |     |     |     |     |
| WINCH                            |     |     |     |     |     |     |     |
| FIBERGLASS BOOMS                 |     |     |     |     |     |     |     |
| FIBERGLASS PLATFORM              |     |     |     |     |     |     |     |
| SLOPE INDICATORS                 |     |     |     |     |     |     |     |
| SAFETY DEVICES                   |     |     |     |     |     |     |     |
| COVERS                           |     |     |     |     |     |     |     |
| NOTES:                           |     |     |     |     |     |     |     |

**DAILY VISUAL INSPECTION**





DAILY VISUAL INSPECTION

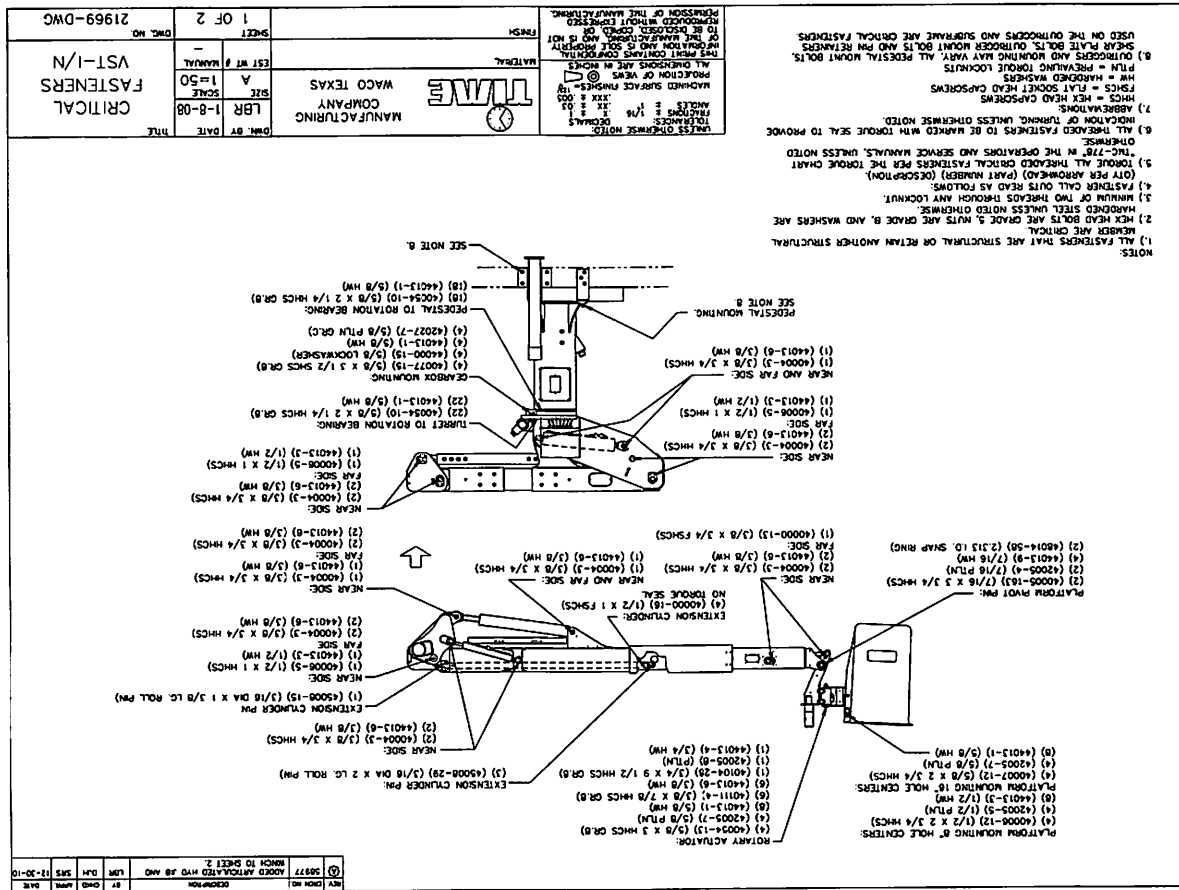
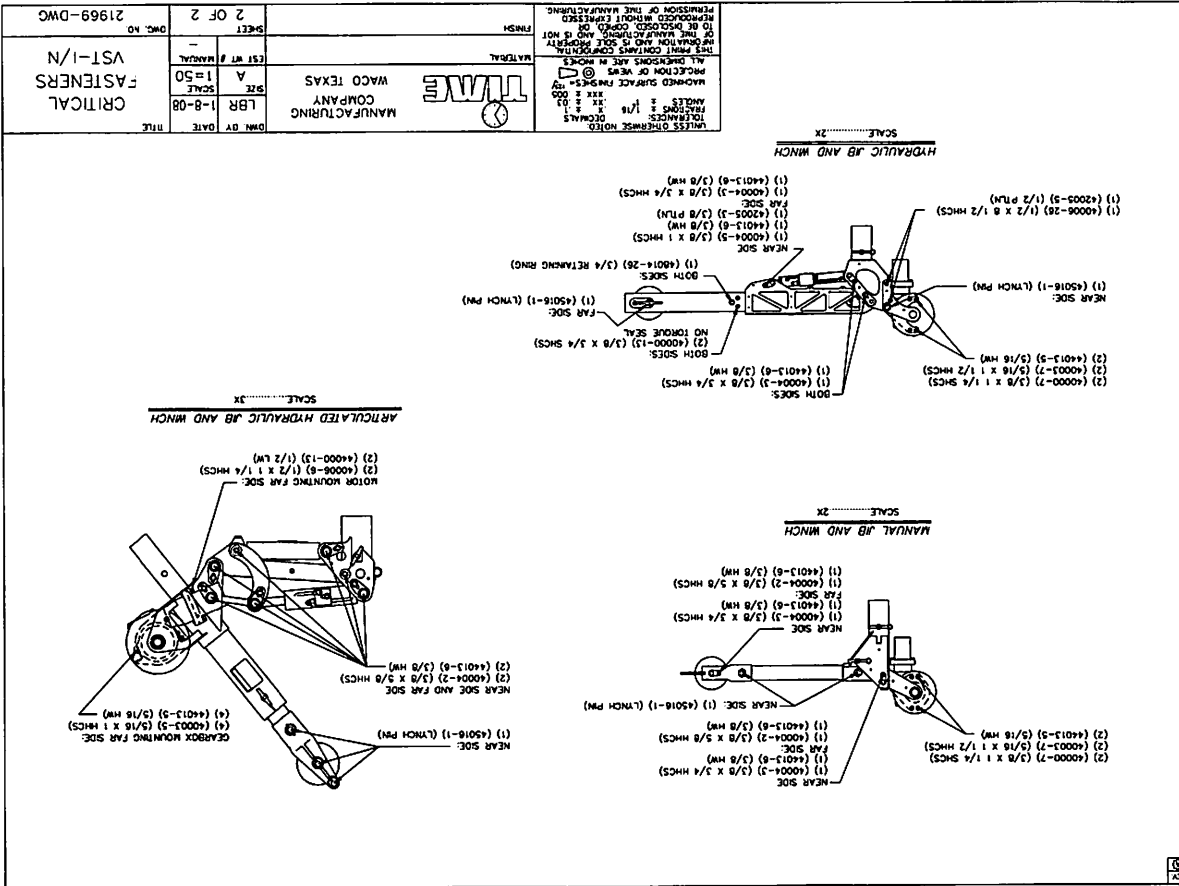

|            |           |            |           |
|------------|-----------|------------|-----------|
| DATE       | BY        | DATE       | BY        |
| 1-8-08     | LBR       | 1-8-08     | LBR       |
| SCALE      | A         | SCALE      | A         |
| 1:50       |           | 1:50       |           |
| EST. WT. # | MANUAL    | EST. WT. # | MANUAL    |
| -          |           | -          |           |
| SHEET      | 2 OF 2    | SHEET      | 2 OF 2    |
| DWG. NO.   | 21969-DWC | DWG. NO.   | 21969-DWC |

|            |           |            |           |
|------------|-----------|------------|-----------|
| DATE       | BY        | DATE       | BY        |
| 1-8-08     | LBR       | 1-8-08     | LBR       |
| SCALE      | A         | SCALE      | A         |
| 1:50       |           | 1:50       |           |
| EST. WT. # | MANUAL    | EST. WT. # | MANUAL    |
| -          |           | -          |           |
| SHEET      | 1 OF 2    | SHEET      | 1 OF 2    |
| DWG. NO.   | 21969-DWC | DWG. NO.   | 21969-DWC |

- NOTES:
1. ALL FASTENERS THAT ARE STRUCTURAL OR RETAIN ANOTHER STRUCTURAL MEMBER ARE CRITICAL.
  2. HEX HEAD BOLTS ARE GRADE 8, NUTS ARE GRADE 8, AND WASHERS ARE HANDLED STEEL UNLESS NOTED OTHERWISE.
  3. PASTEREN CALL OUTS READ AS FOLLOWS:
    4. PASTEREN CALL OUTS READ AS FOLLOWS:
      5. MINIMUM OF TWO THREADS THROUGH ANY LOCKWUT.
      6. PASTEREN CALL OUTS READ AS FOLLOWS:
        7. HANDLED STEEL UNLESS NOTED OTHERWISE.
        8. PASTEREN CALL OUTS READ AS FOLLOWS:
          9. PASTEREN CALL OUTS READ AS FOLLOWS:
            10. MINIMUM OF TWO THREADS THROUGH ANY LOCKWUT.
            11. MINIMUM OF TWO THREADS THROUGH ANY LOCKWUT.
            12. MINIMUM OF TWO THREADS THROUGH ANY LOCKWUT.
            13. MINIMUM OF TWO THREADS THROUGH ANY LOCKWUT.
            14. MINIMUM OF TWO THREADS THROUGH ANY LOCKWUT.
            15. MINIMUM OF TWO THREADS THROUGH ANY LOCKWUT.
            16. MINIMUM OF TWO THREADS THROUGH ANY LOCKWUT.
            17. MINIMUM OF TWO THREADS THROUGH ANY LOCKWUT.
            18. MINIMUM OF TWO THREADS THROUGH ANY LOCKWUT.
            19. MINIMUM OF TWO THREADS THROUGH ANY LOCKWUT.
            20. MINIMUM OF TWO THREADS THROUGH ANY LOCKWUT.
            21. MINIMUM OF TWO THREADS THROUGH ANY LOCKWUT.
            22. MINIMUM OF TWO THREADS THROUGH ANY LOCKWUT.
            23. MINIMUM OF TWO THREADS THROUGH ANY LOCKWUT.
            24. MINIMUM OF TWO THREADS THROUGH ANY LOCKWUT.
            25. MINIMUM OF TWO THREADS THROUGH ANY LOCKWUT.
            26. MINIMUM OF TWO THREADS THROUGH ANY LOCKWUT.
            27. MINIMUM OF TWO THREADS THROUGH ANY LOCKWUT.
            28. MINIMUM OF TWO THREADS THROUGH ANY LOCKWUT.
            29. MINIMUM OF TWO THREADS THROUGH ANY LOCKWUT.
            30. MINIMUM OF TWO THREADS THROUGH ANY LOCKWUT.
            31. MINIMUM OF TWO THREADS THROUGH ANY LOCKWUT.
            32. MINIMUM OF TWO THREADS THROUGH ANY LOCKWUT.
            33. MINIMUM OF TWO THREADS THROUGH ANY LOCKWUT.
            34. MINIMUM OF TWO THREADS THROUGH ANY LOCKWUT.
            35. MINIMUM OF TWO THREADS THROUGH ANY LOCKWUT.
            36. MINIMUM OF TWO THREADS THROUGH ANY LOCKWUT.
            37. MINIMUM OF TWO THREADS THROUGH ANY LOCKWUT.
            38. MINIMUM OF TWO THREADS THROUGH ANY LOCKWUT.
            39. MINIMUM OF TWO THREADS THROUGH ANY LOCKWUT.
            40. MINIMUM OF TWO THREADS THROUGH ANY LOCKWUT.
            41. MINIMUM OF TWO THREADS THROUGH ANY LOCKWUT.
            42. MINIMUM OF TWO THREADS THROUGH ANY LOCKWUT.
            43. MINIMUM OF TWO THREADS THROUGH ANY LOCKWUT.
            44. MINIMUM OF TWO THREADS THROUGH ANY LOCKWUT.
            45. MINIMUM OF TWO THREADS THROUGH ANY LOCKWUT.
            46. MINIMUM OF TWO THREADS THROUGH ANY LOCKWUT.
            47. MINIMUM OF TWO THREADS THROUGH ANY LOCKWUT.
            48. MINIMUM OF TWO THREADS THROUGH ANY LOCKWUT.
            49. MINIMUM OF TWO THREADS THROUGH ANY LOCKWUT.
            50. MINIMUM OF TWO THREADS THROUGH ANY LOCKWUT.
            51. MINIMUM OF TWO THREADS THROUGH ANY LOCKWUT.
            52. MINIMUM OF TWO THREADS THROUGH ANY LOCKWUT.
            53. MINIMUM OF TWO THREADS THROUGH ANY LOCKWUT.
            54. MINIMUM OF TWO THREADS THROUGH ANY LOCKWUT.
            55. MINIMUM OF TWO THREADS THROUGH ANY LOCKWUT.
            56. MINIMUM OF TWO THREADS THROUGH ANY LOCKWUT.
            57. MINIMUM OF TWO THREADS THROUGH ANY LOCKWUT.
            58. MINIMUM OF TWO THREADS THROUGH ANY LOCKWUT.
            59. MINIMUM OF TWO THREADS THROUGH ANY LOCKWUT.
            60. MINIMUM OF TWO THREADS THROUGH ANY LOCKWUT.
            61. MINIMUM OF TWO THREADS THROUGH ANY LOCKWUT.
            62. MINIMUM OF TWO THREADS THROUGH ANY LOCKWUT.
            63. MINIMUM OF TWO THREADS THROUGH ANY LOCKWUT.
            64. MINIMUM OF TWO THREADS THROUGH ANY LOCKWUT.
            65. MINIMUM OF TWO THREADS THROUGH ANY LOCKWUT.
            66. MINIMUM OF TWO THREADS THROUGH ANY LOCKWUT.
            67. MINIMUM OF TWO THREADS THROUGH ANY LOCKWUT.
            68. MINIMUM OF TWO THREADS THROUGH ANY LOCKWUT.
            69. MINIMUM OF TWO THREADS THROUGH ANY LOCKWUT.
            70. MINIMUM OF TWO THREADS THROUGH ANY LOCKWUT.
            71. MINIMUM OF TWO THREADS THROUGH ANY LOCKWUT.
            72. MINIMUM OF TWO THREADS THROUGH ANY LOCKWUT.
            73. MINIMUM OF TWO THREADS THROUGH ANY LOCKWUT.
            74. MINIMUM OF TWO THREADS THROUGH ANY LOCKWUT.
            75. MINIMUM OF TWO THREADS THROUGH ANY LOCKWUT.
            76. MINIMUM OF TWO THREADS THROUGH ANY LOCKWUT.
            77. MINIMUM OF TWO THREADS THROUGH ANY LOCKWUT.
            78. MINIMUM OF TWO THREADS THROUGH ANY LOCKWUT.
            79. MINIMUM OF TWO THREADS THROUGH ANY LOCKWUT.
            80. MINIMUM OF TWO THREADS THROUGH ANY LOCKWUT.
            81. MINIMUM OF TWO THREADS THROUGH ANY LOCKWUT.
            82. MINIMUM OF TWO THREADS THROUGH ANY LOCKWUT.
            83. MINIMUM OF TWO THREADS THROUGH ANY LOCKWUT.
            84. MINIMUM OF TWO THREADS THROUGH ANY LOCKWUT.
            85. MINIMUM OF TWO THREADS THROUGH ANY LOCKWUT.
            86. MINIMUM OF TWO THREADS THROUGH ANY LOCKWUT.
            87. MINIMUM OF TWO THREADS THROUGH ANY LOCKWUT.
            88. MINIMUM OF TWO THREADS THROUGH ANY LOCKWUT.
            89. MINIMUM OF TWO THREADS THROUGH ANY LOCKWUT.
            90. MINIMUM OF TWO THREADS THROUGH ANY LOCKWUT.
            91. MINIMUM OF TWO THREADS THROUGH ANY LOCKWUT.
            92. MINIMUM OF TWO THREADS THROUGH ANY LOCKWUT.
            93. MINIMUM OF TWO THREADS THROUGH ANY LOCKWUT.
            94. MINIMUM OF TWO THREADS THROUGH ANY LOCKWUT.
            95. MINIMUM OF TWO THREADS THROUGH ANY LOCKWUT.
            96. MINIMUM OF TWO THREADS THROUGH ANY LOCKWUT.
            97. MINIMUM OF TWO THREADS THROUGH ANY LOCKWUT.
            98. MINIMUM OF TWO THREADS THROUGH ANY LOCKWUT.
            99. MINIMUM OF TWO THREADS THROUGH ANY LOCKWUT.
            100. MINIMUM OF TWO THREADS THROUGH ANY LOCKWUT.

|            |           |            |           |
|------------|-----------|------------|-----------|
| DATE       | BY        | DATE       | BY        |
| 1-8-08     | LBR       | 1-8-08     | LBR       |
| SCALE      | A         | SCALE      | A         |
| 1:50       |           | 1:50       |           |
| EST. WT. # | MANUAL    | EST. WT. # | MANUAL    |
| -          |           | -          |           |
| SHEET      | 1 OF 2    | SHEET      | 1 OF 2    |
| DWG. NO.   | 21969-DWC | DWG. NO.   | 21969-DWC |



|     |          |  |     |      |      |          |
|-----|----------|--|-----|------|------|----------|
| REV | DRWN NO. | DESCRIPTION                                    | BY  | CHKD | APPR | DATE     |
| ①   | 50017    | ADD ARTICULATED HYD. JB AND WINCH AND SHEET 2. | LBR | DLH  | SRS  | 12-25-10 |

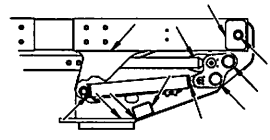

**SECTION A-A**  
SCALE.....1.5X

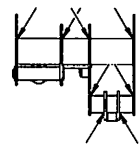

**SECTION B-B**  
SCALE.....2X

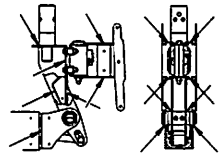

**PLATFORM SUPPORT**  
SCALE.....2X

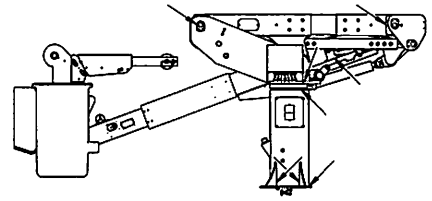
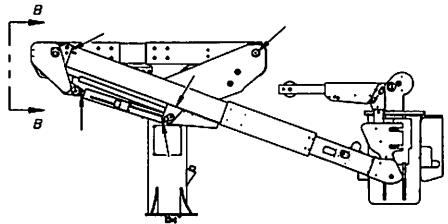
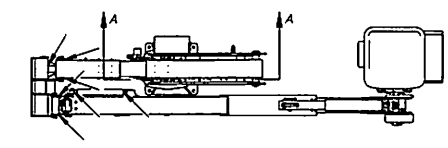

**NOTES:**

- 1.) CRITICAL WELDED JOINTS TO BE INSPECTED ARE INDICATED BY ARROWS. THE JOINTS MAY INCLUDE WELDS ON BOTH SIDES OR INSIDE AND OUTSIDE AS APPLICABLE.
- 2.) THERE ARE ADDITIONAL CRITICAL WELDS ON THE MOUNTING HARDWARE AND OUTRIGGERS.
- 3.) ALL WELDED PIN RETAINERS ARE CRITICAL WELDS.
- 4.) ANY STRUCTURAL WELD FOUND DEFECTIVE SHOULD BE CORRECTED AND NEVER IGNORED. WELDS MUST BE REPAIRED IN ACCORDANCE WITH ANSI A92.2 REQUIREMENTS. CONSULT FACTORY FOR MATERIAL SPECIFICATIONS AND PROPER WELDING SPECIFICATIONS.

UNLESS OTHERWISE NOTED:  
 TOLERANCES: DECIMALS  
 FRACTIONS ± 1/16 X ± .03  
 ANGLES ± .1° XX ± .005  
 MACHINED SURFACE FINISHES = 125  
 PROJECTION OF VIEWS  
 ALL DIMENSIONS ARE IN INCHES  
 THIS PRINT CONTAINS CONFIDENTIAL INFORMATION AND IS SOLE PROPERTY OF THE MANUFACTURING COMPANY AND IS NOT TO BE DISCLOSED, COPIED, OR REPRODUCED WITHOUT EXPRESSED PERMISSION OF THE MANUFACTURING COMPANY.

|                                     |          |          |                      |
|-------------------------------------|----------|----------|----------------------|
| MANUFACTURING COMPANY<br>WACO TEXAS | DRWN BY  | DATE     | TITLE                |
|                                     | LBR      | 12-18-07 | VST-36,40,47,52-1    |
| MATERIAL                            | SIZE     | SCALE    | CRITICAL WELDS       |
|                                     | A        | 1=55     |                      |
| FINISH                              | EST WT # | MANUAL   | DWG NO.<br>21962-DWG |
|                                     | —        | —        |                      |
| SHEET 1 OF 2                        |          |          |                      |

REV ②

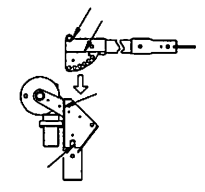

**MANUAL JB AND WINCH**  
SCALE.....2X

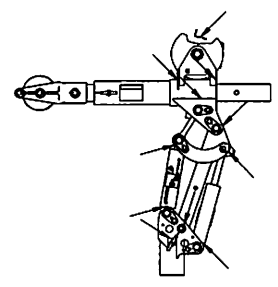

**ARTICULATED HYDRAULIC JB AND WINCH**  
SCALE.....2.67X

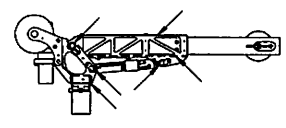

**HYDRAULIC JB AND WINCH**  
SCALE.....2X

UNLESS OTHERWISE NOTED:  
 TOLERANCES: DECIMALS  
 FRACTIONS ± 1/16 X ± .03  
 ANGLES ± .1° XX ± .005  
 MACHINED SURFACE FINISHES = 125  
 PROJECTION OF VIEWS  
 ALL DIMENSIONS ARE IN INCHES  
 THIS PRINT CONTAINS CONFIDENTIAL INFORMATION AND IS SOLE PROPERTY OF THE MANUFACTURING COMPANY AND IS NOT TO BE DISCLOSED, COPIED, OR REPRODUCED WITHOUT EXPRESSED PERMISSION OF THE MANUFACTURING COMPANY.

|                                     |          |          |                      |
|-------------------------------------|----------|----------|----------------------|
| MANUFACTURING COMPANY<br>WACO TEXAS | DRWN BY  | DATE     | TITLE                |
|                                     | LBR      | 12-18-07 | VST-36,40,47,52-1    |
| MATERIAL                            | SIZE     | SCALE    | CRITICAL WELDS       |
|                                     | A        | 1=55     |                      |
| FINISH                              | EST WT # | MANUAL   | DWG NO.<br>21962-DWG |
|                                     | —        | —        |                      |
| SHEET 2 OF 2                        |          |          |                      |



# DAILY VISUAL INSPECTION

REV 2

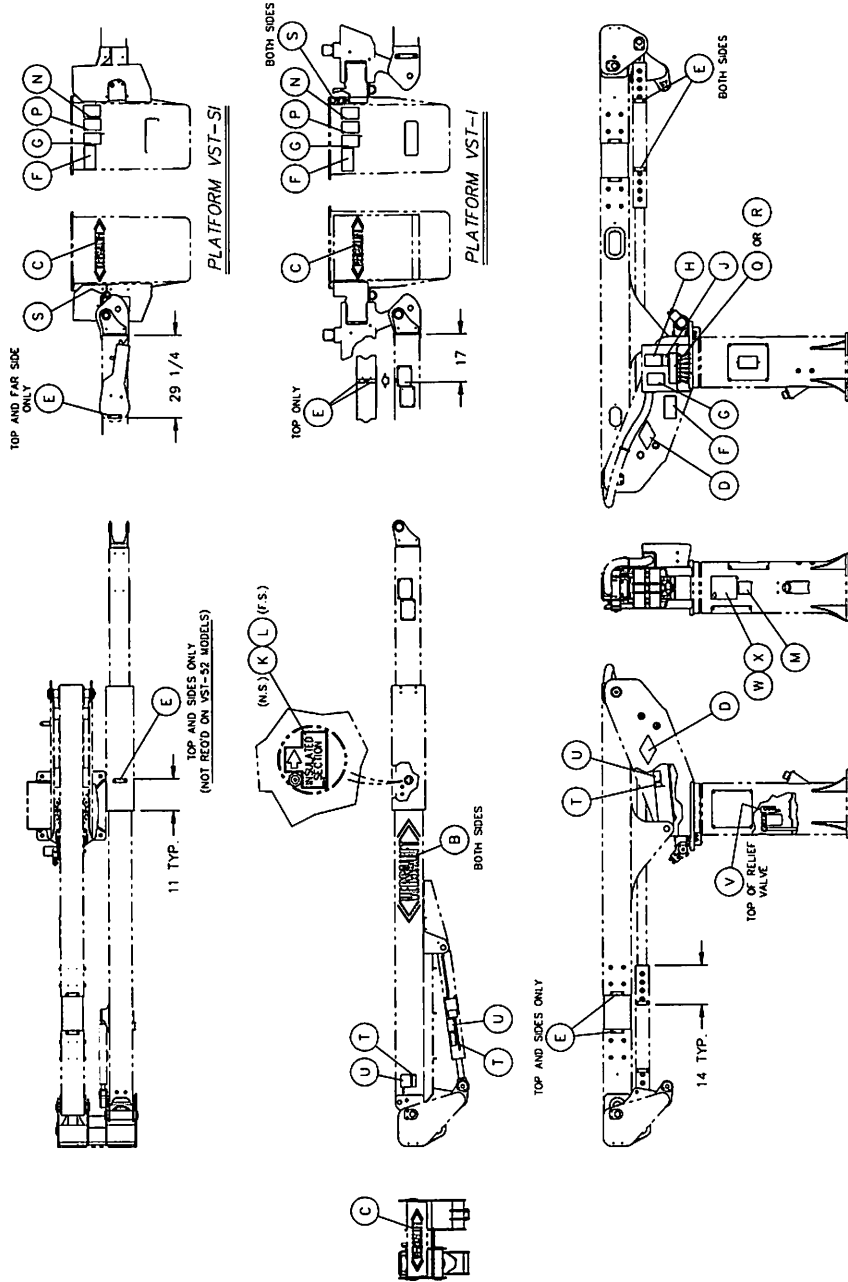

NOTE:  
 1.) INDICATES PARTS TO BE SHIPPED LOOSE.  
 2.) ITEM "Y" TO BE MOUNTED FRONT, REAR AND EACH SIDE OF CHASSIS.

SEE NOTE 2 \*

| QTY. | ITEM | PART NO.      | DESCRIPTION                       |
|------|------|---------------|-----------------------------------|
| 4    | 4    | Y 4542-2      | DECAL, ELECTROUTION               |
| 1    | 1    | X 1006487-1   | DATA PLATE, BACKING               |
| 1    | 1    | W 1006486-1   | DATA PLATE                        |
| 1    | 1    | V 7584-1      | DECAL, RELIEF ADJUSTMENT          |
| 3    | 3    | U 7500-1      | DECAL, HOLDING VALVE              |
| 3    | 3    | T 15232-1     | DECAL, CAUTION, ENEMY LOWERING    |
| 2    | 2    | S 30593-1     | DECAL, LANYARD ATTACHMENT         |
| -    | 1    | R 1006289-2   | DECAL, LOWER CONTROL              |
| 1    | -    | Q 1006289-1   | DECAL, LOWER CONTROL              |
| 1    | 1    | P 14014-1     | DECAL, PLATFORM INSTRUCTION       |
| 1    | 1    | N 14110-1     | DECAL, ELECTROUTION HAZARD        |
| 1    | 1    | M 12337-1     | DECAL, OWNER TRANSFER             |
| 1    | 1    | L 7393-1      | DECAL, INSULATED SECTION          |
| 1    | 1    | K 7393-2      | DECAL, INSULATED SECTION          |
| 1    | 1    | J 13144-1     | DECAL, CAUTION, LOWER BOOM        |
| 1    | 1    | H 4542-4      | DECAL, DANGER, ELECTROUTION       |
| 2    | 2    | G 4542-5      | DECAL, CAUTION, OPERATION         |
| 2    | 2    | F 4542-12     | DECAL, DANGER, QUALIFIED OPERATOR |
| 15   | 15   | E 5098-1      | DECAL, "INSULATED SECTION"        |
| 2    | 2    | D 428-011     | VERSALIFT NAME PLATE              |
| 2    | 2    | C 4541-1      | DECAL, "VERSALIFT" (SMALL)        |
| 2    | 2    | B 4541-2      | DECAL, "VERSALIFT" (LARGE)        |
| 2    | 2    | A 1006506-DWC | DECAL, PLACEMENT DRAWING          |

| LIST OF MATERIAL |    | QTY. | ITEM        | PART NO.                          | DESCRIPTION |
|------------------|----|------|-------------|-----------------------------------|-------------|
| 2                | 2  | A    | 1006506-DWC | DECAL, PLACEMENT DRAWING          |             |
| 2                | 2  | B    | 4541-2      | DECAL, "VERSALIFT" (LARGE)        |             |
| 2                | 2  | C    | 4541-1      | DECAL, "VERSALIFT" (SMALL)        |             |
| 2                | 2  | D    | 428-011     | VERSALIFT NAME PLATE              |             |
| 15               | 15 | E    | 5098-1      | DECAL, "INSULATED SECTION"        |             |
| 2                | 2  | F    | 4542-12     | DECAL, DANGER, QUALIFIED OPERATOR |             |
| 2                | 2  | G    | 4542-5      | DECAL, CAUTION, OPERATION         |             |
| 1                | 1  | H    | 4542-4      | DECAL, DANGER, ELECTROUTION       |             |
| 1                | 1  | J    | 13144-1     | DECAL, CAUTION, LOWER BOOM        |             |
| 1                | 1  | K    | 7393-2      | DECAL, INSULATED SECTION          |             |
| 1                | 1  | L    | 7393-1      | DECAL, INSULATED SECTION          |             |
| 1                | 1  | M    | 12337-1     | DECAL, OWNER TRANSFER             |             |
| 1                | 1  | N    | 14110-1     | DECAL, ELECTROUTION HAZARD        |             |
| 1                | 1  | P    | 14014-1     | DECAL, PLATFORM INSTRUCTION       |             |
| 1                | -  | Q    | 1006289-1   | DECAL, LOWER CONTROL              |             |
| -                | 1  | R    | 1006289-2   | DECAL, LOWER CONTROL              |             |
| 2                | 2  | S    | 30593-1     | DECAL, LANYARD ATTACHMENT         |             |
| 3                | 3  | T    | 15232-1     | DECAL, CAUTION, ENEMY LOWERING    |             |
| 3                | 3  | U    | 7500-1      | DECAL, HOLDING VALVE              |             |
| 1                | 1  | V    | 7584-1      | DECAL, RELIEF ADJUSTMENT          |             |
| 1                | 1  | W    | 1006486-1   | DATA PLATE                        |             |
| 1                | 1  | X    | 1006487-1   | DATA PLATE, BACKING               |             |
| 4                | 4  | Y    | 4542-2      | DECAL, ELECTROUTION               |             |

UNLESS OTHERWISE SPECIFIED, DIMENSIONS ARE IN INCHES AND DECIMALS THEREOF. DIMENSIONS IN PARENTHESES ARE FOR INFORMATION ONLY. ALL DIMENSIONS ARE TO CENTER UNLESS OTHERWISE SPECIFIED. DIMENSIONS TO BE CHECKED, CONTROLLED, OR INSPECTED BY THE MANUFACTURER.

| DASH NO. | DESCRIPTION                   | CODE        |
|----------|-------------------------------|-------------|
| -1       | DECAL PLACMNT INSUL W/O WINCH | DE-1260-161 |
| -2       | DECAL PLACMNT INSUL W/ WINCH  | DE-1260-162 |

MANUFACTURING COMPANY  
 WACO TEXAS  
 TIME  
 SEE LIST OF MATERIAL  
 SHEET 1 OF 1  
 Dwg. No. 1006506-DWC

