

Operation

Table of Contents

Introduction	2	Shipping and Handling	7
Qualified Persons	2	Inspection	7
Read this Instruction Sheet	2	Storage	7
Retain this Instruction Sheet	2	Application Overview	8
Proper Application.....	2	Single-Pole Switching	8
Safety Information	4	Restrictions on Overhead and Underground Use	8
Understanding Safety-Alert Messages	4	Clearance Requirements for Use in	
Following Safety Instructions.....	4	Pad-Mounted Gear.....	8
Replacement Instructions and Labels	4	Operating Considerations	9
Location of Safety Labels	5	Operation	12
Safety Precautions	6	Overhead Distribution Devices.....	12
		Pad-Mounted Gear.....	15
		Understanding the Operation Counter.....	17



Introduction

Qualified Persons

WARNING

Only qualified persons knowledgeable in the installation, operation, and maintenance of overhead and underground electric distribution equipment, along with all associated hazards, may install, operate, and maintain the equipment covered by this publication. A qualified person is someone trained and competent in:

- The skills and techniques necessary to distinguish exposed live parts from nonlive parts of electrical equipment
- The skills and techniques necessary to determine the proper approach distances corresponding to the voltages to which the qualified person will be exposed
- The proper use of special precautionary techniques, personal protective equipment, insulated and shielding materials, and insulated tools for working on or near exposed energized parts of electrical equipment

These instructions are intended only for such qualified persons. They are not intended to be a substitute for adequate training and experience in safety procedures for this type of equipment.

Read this Instruction Sheet

NOTICE

Thoroughly and carefully read this instruction sheet and all materials included in the product's instruction handbook before installing or operating the Loadbuster tool. Become familiar with the Safety Information on pages 4 through 5 and Safety Precautions on page 6. The latest version of this publication is available online in PDF format at sandc.com/en/contact-us/product-literature/.

Retain this Instruction Sheet

This instruction sheet is a permanent part of the Loadbuster tool. Designate a location where users can easily retrieve and refer to this publication.

Proper Application

WARNING

The Loadbuster tool must only be used for specific switching applications within the ratings of the tool selected. Loadbuster tool ratings are listed on a ratings label attached to the chassis of the tool. Ratings are also listed in Table 1 on page 3 and in S&C Specification Bulletin 811-31.

When used with appropriately designed “hook-equipped” disconnects, cutouts, power fuses, fuse limiters, pad-mounted gear, and S&C single-pole reclosers and interrupters, the Loadbuster tool is suitable for these live-switching duties of single- or three-phase overhead distribution circuits through 34.5 kV and underground distribution circuits through 25 kV. It is essential to make sure the Loadbuster tool being used is properly rated for the application. See the information below as well as the information in the “Application Overview” section on page 8:

- Transformer switching—Transformer load currents up through 600 amperes nominal, 900 amperes maximum, as well as transformer magnetizing currents associated with the applicable loads
- Line switching—Load-splitting (parallel or loop switching) and load-dropping of currents up through 600 amperes nominal, 900 amperes maximum; also line-dropping (charging currents typical for distribution systems of these voltage ratings)
- Cable switching—Load-splitting (parallel or loop switching) and load-dropping of currents up through 600 amperes nominal, 900 amperes maximum; also cable-dropping (charging currents typical for distribution systems of these voltage ratings)
- Capacitor bank switching—Switching of single capacitor banks, as shown in Table 2

Table 1. Loadbuster Tool Ratings

Item	Rating				Catalog Number
	kV		Amps, Interrupting		
	Nom.	Max	Nom.	Max	
Loadbuster—The S&C Loadbreak Tool, use with overhead distribution devices	14.4/25	27	600	900	5300R3
Loadbuster—The S&C Loadbreak Tool, use in suitably designed pad-mounted gear	14.4/25	27	600	900	5300R3-E
Loadbuster—The S&C Loadbreak Tool, use with overhead distribution devices	25/34.5	38	600	900	5400R3

Table 2. Capacitor Bank Ratings

Loadbuster Catalog Number	Nominal System Voltage, kV, Three-Phase	Maximum Capacitor Bank Rating, kVac, Three Phase		
		Solidly or Effectively Grounded System		Ungrounded System
		Single ^① Banks, Grounded-Wye Connected	Single ^① Banks, Ungrounded-Wye Connected	Single ^① Banks, Grounded- or Ungrounded-Wye Connected
5300R3	12 through 14.4	1800	1800	1800
	16	2400	2400	2400
	20.8 through 23.9	3000	●	●
	24.9 and 26	3600	●	●
5400R3	20.8 through 23.9	3000	3000	3000
	24.9 and 26	3600	3600	3600
	27.6	3600	3600	3600
	34.5	4800	●	●

① Loadbuster tools must not be used for switching parallel (“back-to-back”) capacitor banks.

● Loadbuster tools must not be used for switching ungrounded-wye connected banks—or grounded-wye connected banks on ungrounded systems—where maximum system operating voltage exceeds 18 kV for Loadbuster tool catalog number 5300R3 or 29 kV for Loadbuster tool catalog number 5400R3.

Safety Information

Understanding Safety-Alert Messages

Several types of safety-alert messages may appear throughout this instruction sheet and on labels and tags attached to the product. Become familiar with these types of messages and the importance of these signal words:

DANGER

“DANGER” identifies the most serious and immediate hazards that will likely result in serious personal injury or death if instructions, including recommended precautions, are not followed.

WARNING

“WARNING” identifies hazards or unsafe practices that can result in serious personal injury or death if instructions, including recommended precautions, are not followed.

CAUTION

“CAUTION” identifies hazards or unsafe practices that can result in minor personal injury if instructions, including recommended precautions, are not followed.

NOTICE

“NOTICE” identifies important procedures or requirements that can result in product or property damage if instructions are not followed.

Following Safety Instructions

If any portion of this instruction sheet is unclear and assistance is needed, contact the nearest S&C Sales Office or S&C Authorized Distributor. Their telephone numbers are listed on S&C’s website sandc.com, or call the S&C Global Support and Monitoring Center at 1-888-762-1100.

NOTICE

Read this instruction sheet thoroughly and carefully before operating the Loadbuster tool.



Replacement Instructions and Labels

If additional copies of this instruction sheet are required, contact the nearest S&C Sales Office, S&C Authorized Distributor, S&C Headquarters, or S&C Electric Canada Ltd.

It is important that any missing, damaged, or faded labels on the equipment be replaced immediately. Replacement labels are available by contacting the nearest S&C Sales Office, S&C Authorized Distributor, S&C Headquarters, or S&C Electric Canada Ltd.

Location of Safety Labels

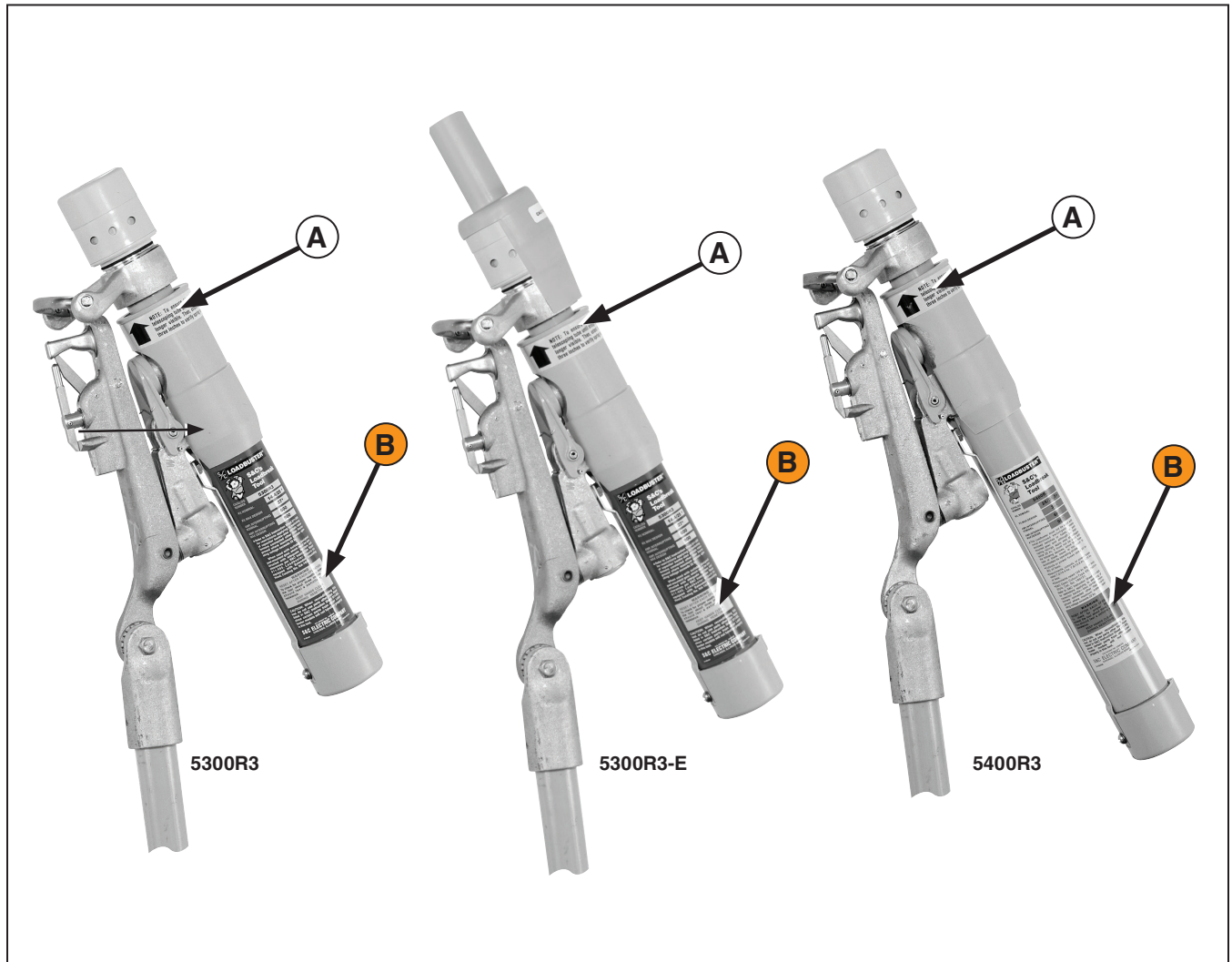

Reorder Information for Safety Labels

Location	Safety Alert Message	Description	Part Number
A	INSTRUCTIONAL NOTE	To ensure resetting, depress telescoping tube until orange band . . .	G-5840R1
B	⚠ WARNING	RESET AFTER EACH OPERATION—To check for proper resetting . . .	G-4401 (for 5300R3) G-4401 (for 5300R3-E) G-4320 (for 5400R3)

DANGER



The Loadbuster loadbreak tool is used to switch equipment that operates at high voltage. Failure to observe the precautions below will result in serious personal injury or death.

Some of these precautions may differ from your company's operating procedures and rules. Where a discrepancy exists, follow your company's operating procedures and rules.

1. **QUALIFIED PERSONS.** Access to a Loadbuster loadbreak tool must be restricted only to qualified persons. See the "Qualified Persons" section on page 2.
2. **SAFETY PROCEDURES.** Always follow safe operating procedures and rules. Always maintain proper clearance from energized components.
3. **PERSONAL PROTECTIVE EQUIPMENT.** Always use suitable protective equipment, such as rubber gloves, rubber mats, hard hats, safety glasses, arc flash clothing, and fall protection in accordance with safe operating procedures and rules.
4. **SAFETY LABELS and TAGS .** Do not remove or obscure any of the "DANGER," "WARNING," "CAUTION," or "NOTICE" labels. Remove tags only if instructed to do so.
5. **ENERGIZED COMPONENTS.** Always consider all parts live until de-energized, tested, and grounded.
6. **MAINTAINING PROPER CLEARANCE.** Always maintain proper clearance from energized components.
7. **OPERATION.** Never position the Loadbuster loadbreak tool so the outer tube obscures the line of vision. See Figure 1 on page 9 for correct positioning.
8. **RESETTING.** Keep hands clear during resetting. The Loadbuster tool is spring-loaded. Pulling the resetting latch will cause the anchor end of the tool to move down quickly. Keep hands in the position shown in Figure 7 on page 14.

Inspection

Examine the shipment for external evidence of damage as soon after receipt as possible, preferably before removal from the carrier's conveyance. Check the bill of lading to make sure all listed shipping skids, crates, cartons, and containers are present.

If there is visible loss and/or damage:

1. Notify the delivering carrier immediately.
2. Ask for a carrier inspection.
3. Note condition of shipment on all copies of the delivery receipt.
4. File a claim with the carrier.

If concealed damage is discovered:

1. Notify the delivering carrier within 15 days of receipt of shipment.
2. Ask for a carrier inspection.
3. File a claim with the carrier.

Also, notify S&C Electric Company in all instances of loss or damage.

Storage

NOTICE

A carrying case, catalog number 5380R1, is recommended for the Loadbuster tool. The molded, high-density polyethylene carrying case protects the Loadbuster tool against potentially damaging vibration, mechanical shock, and contamination during storage or transport.

Single-Pole Switching

In single-pole switching of ungrounded-primary three-phase transformers or banks (or single-phase transformers connected line to line), circuit connections or parameters may, in some cases, produce excessive overvoltages. In particular, for the following applications above 22 kV, single-pole switching by any means—including with the use of the Loadbuster tool—should be performed only under the conditions stated in italics:

- Switching unloaded or lightly loaded delta-connected or ungrounded-primary wye-wye connected three-phase transformers or banks (or line-to-line connected single-phase transformers), rated 150 kVA or less three-phase, or 50 kVA or less single-phase—or of any kVA rating when combined with unloaded cables or lines—where the maximum system operating voltage exceeds 22 kV (*Single-pole switching should be performed only if each phase is carrying 5% load or more or if the transformer or bank is temporarily grounded at the primary neutral during switching.*)
- Switching loaded or unloaded ungrounded-primary wye-delta connected three-phase transformers or banks—alone or combined with unloaded cables or lines—where maximum system operating voltage exceeds 22 kV (*Single-pole switching should be performed only if each phase is carrying 5% load or more and if the lighting-load phase is always switched open first [or switched closed last] or if the transformer or bank is temporarily grounded at the primary neutral during switching.*)

Restrictions on Overhead and Underground Use

The Loadbuster tool must be used only with disconnects, cutouts, power fuses, fuse limiters, or pad-mounted gear that meet S&C's applicable minimum construction specifications found in the latest version of S&C Data Bulletin 811-60.

NOTICE

Loadbuster tool catalog number 5400R3, rated 25/34.5 kV, must not be used with metal-enclosed switchgear, metal-enclosed switches or fuses, or pad-mounted gear, of any make.

Although the interrupting ratings of Loadbuster tool catalog number 5400R3, rated 25/34.5 kV, are equally applicable at lower voltages, the tool must not be used with the following devices because the fuse tube or blade travel of such devices is too short to accommodate the Loadbuster tool's operating stroke:

- Cutouts, power fuses, or fuse limiters of any make rated 110 kV BIL or less
- Disconnects, cutouts, power fuses, or fuse limiters of any make rated 7.2/14.4 kV, 7.8/13.8 kV, 8.25 kV, or less
- Disconnects of any make rated 125 kV BIL or less
- Station-style Type XS Fuse Cutouts, catalog number 189131 (with or without catalog number supplements)

Loadbuster tools should not be used for any applications where maximum system operating voltage exceeds the Loadbuster tool's maximum voltage rating.

Clearance Requirements for Use in Pad-Mounted Gear

For applications of the Loadbuster tool (catalog number 5300R3-E) in pad-mounted gear, the Loadbuster tool must be equipped with an extended insulating hood (catalog number NA-1034), and the pad-mounted gear must be equipped with rigid insulating barriers to prevent:

- Accidental contact of the Loadbuster tool's metal parts with adjacent phases during switching
- Accidental grounding of the Loadbuster tool's metal parts to enclosure walls, door stiles, or switch mounting bases during switching

Specifically, barriers must ensure the minimum clearances shown in Table 3 between metal parts of the Loadbuster tool and ground during a switching operation.

Table 3. Minimum Barrier Clearances

Maximum System Operating Voltage, kV	Clearance, Inches (mm)
Up through 15.5	1 (25)
Above 15.5 through 27	2 (51)

Pay close attention to the following operating considerations:

- Never position the Loadbuster tool so its outer tube obscures the line of vision. See Figure 1 for correct positioning.
- To coordinate the Loadbuster tool (catalog number 5300R3) maximum voltage rating of 27 kV when used with fuse cutouts, disconnects, power fuses, or fuse limiters made by another manufacture, the open gap on the cutout, disconnect, fuse, or fuse limiter when the tool is ready to trip must approximate 3 inches (76 mm) minimum. (For more details, see S&C Data Bulletin 811-60.)
- To coordinate the Loadbuster tool's (catalog number 5400R3) maximum voltage rating of 38 kV when used with fuse cutouts, disconnects, power fuses, or fuse limiters of another manufacture, the open gap on the cutout, disconnect, fuse, or fuse limiter when the tool is ready to trip must approximate 5¼ inches (133 mm) minimum. (For a more detailed discussion of this and other requirements, see S&C Data Bulletin 811-60.)
- After each operation, immediately remove the Loadbuster tool from the fuse cutout, disconnect, power fuse, fuse limiter, or pad-mounted gear and reset it. Instructions for resetting the Loadbuster tool can be found in Step 5 on page 14.
- For usual operating conditions, the Loadbuster tool is fastened to a universal pole (stick) not less than 6 feet (183 cm) long (8 feet [244 cm] for catalog number 5400R3) with the frame of the tool in line with the pole.
- As shown in Figure 1, Detail A or B, the Loadbuster tool must be attached so it reaches across in front of the fuse cutout, disconnect, power fuse, or fuse limiter. That is, the Loadbuster anchor must be hooked to the attachment hook on the far side of the device. The Loadbuster tool should never be attached with its anchor hooked on the closest side of the fuse cutout or other device, as shown in Figure 1, Detail C or D. Attaching the tool in this manner would not only obscure the operator's line of vision, but it could also result in placing a bending stress on the tool and make disengagement difficult.

When the Loadbuster tool is properly attached, as shown in Figure 1, Detail A or B, a downward pull of the pole to open the fuse cutout, disconnect, power fuse, or fuse limiter extends the Loadbuster tool and charges an internal spring. At a predeter-

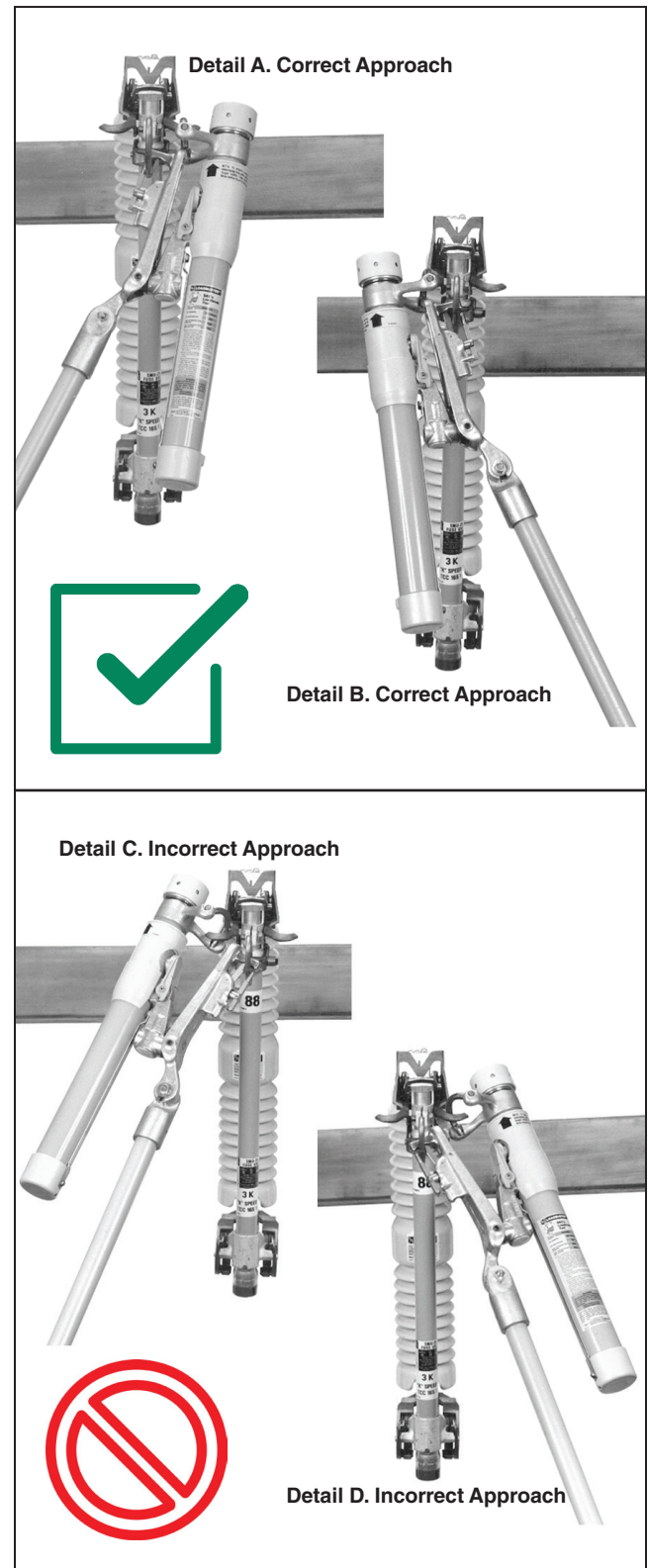

Figure 1. Correct and incorrect approach for Loadbuster—The S&C Loadbreak Tool.

Operating Considerations

mined point in the opening stroke, a trigger inside the tool trips, releasing the charged spring, thus separating the internal contacts and interrupting the circuit. Successful operation is independent of the speed with which the fuse cutout, disconnect, power fuse, or fuse limiter is opened.

NOTICE

When operating from a bucket truck, stay at least 5 feet (152 cm) below the device and in front of fuse cutouts, fuse limiters, and vertically mounted disconnects and fuses. When disconnects are mounted inverted, approach the attachment hook from the hinge end, staying well below the device to be opened so excessive horizontal force is not exerted on the insulator. See Figure 2 and Figure 3 on page 11.

Note: Although many words and illustrations are used here to describe the operation of the Loadbuster tool, correct techniques can be mastered quite easily. S&C advises spending a reasonable amount of time practicing with the Loadbuster tool on a de-energized fuse cutout, power fuse, fuse limiter, recloser, interrupter, or disconnect. The operating steps illustrated in Figure 4 on page 12 through Figure 7 on page 14, covering opening of a power fuse, apply equally to a fuse cutout, fuse limiter, or disconnect. For information on using the Loadbuster tool with the TripSaver® II Cutout-Mounted Recloser, refer to S&C Instruction Sheet 461-502. For information on using the Loadbuster tool with the VacuFuse® II Self-Resetting Interrupter, refer to S&C Instruction Sheet 465-500.

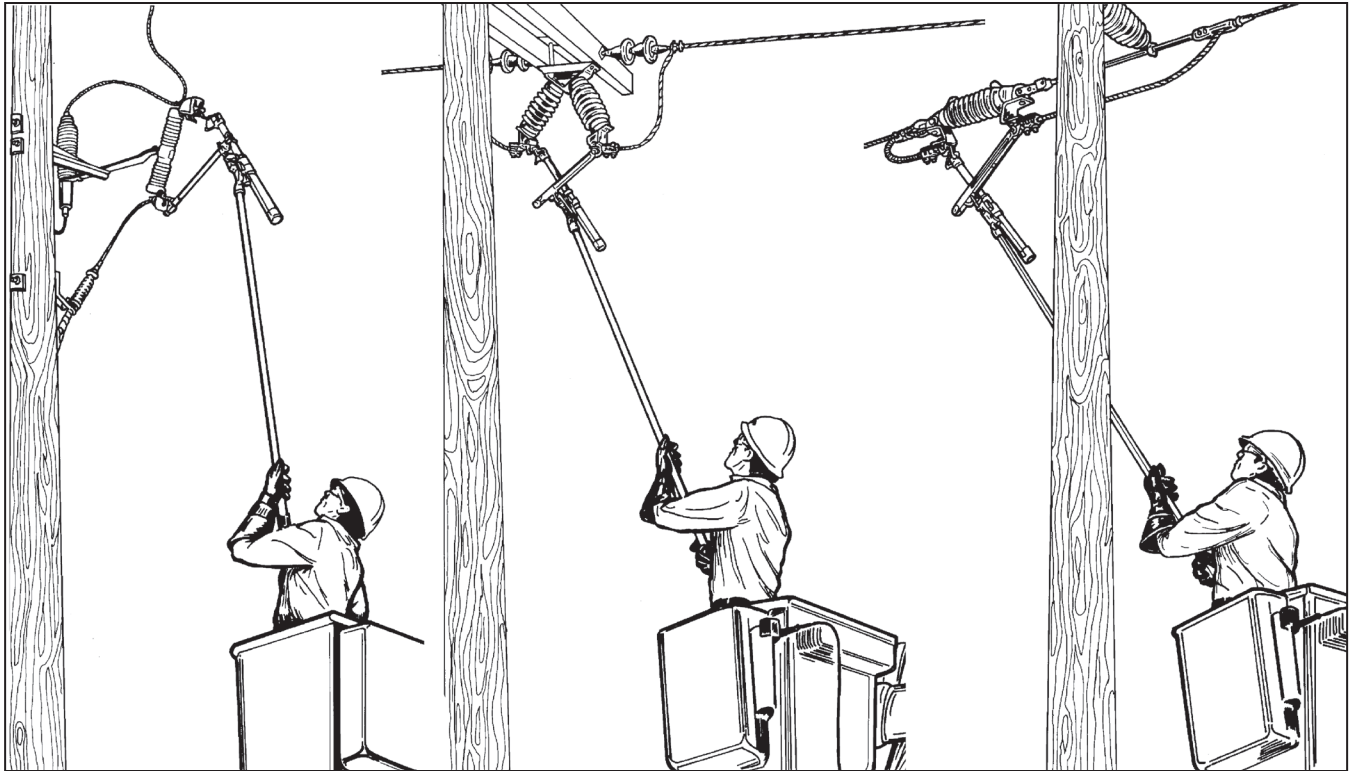

Figure 2. Recommended aerial bucket positions for an operator using the Loadbuster tool with overhead distribution devices.

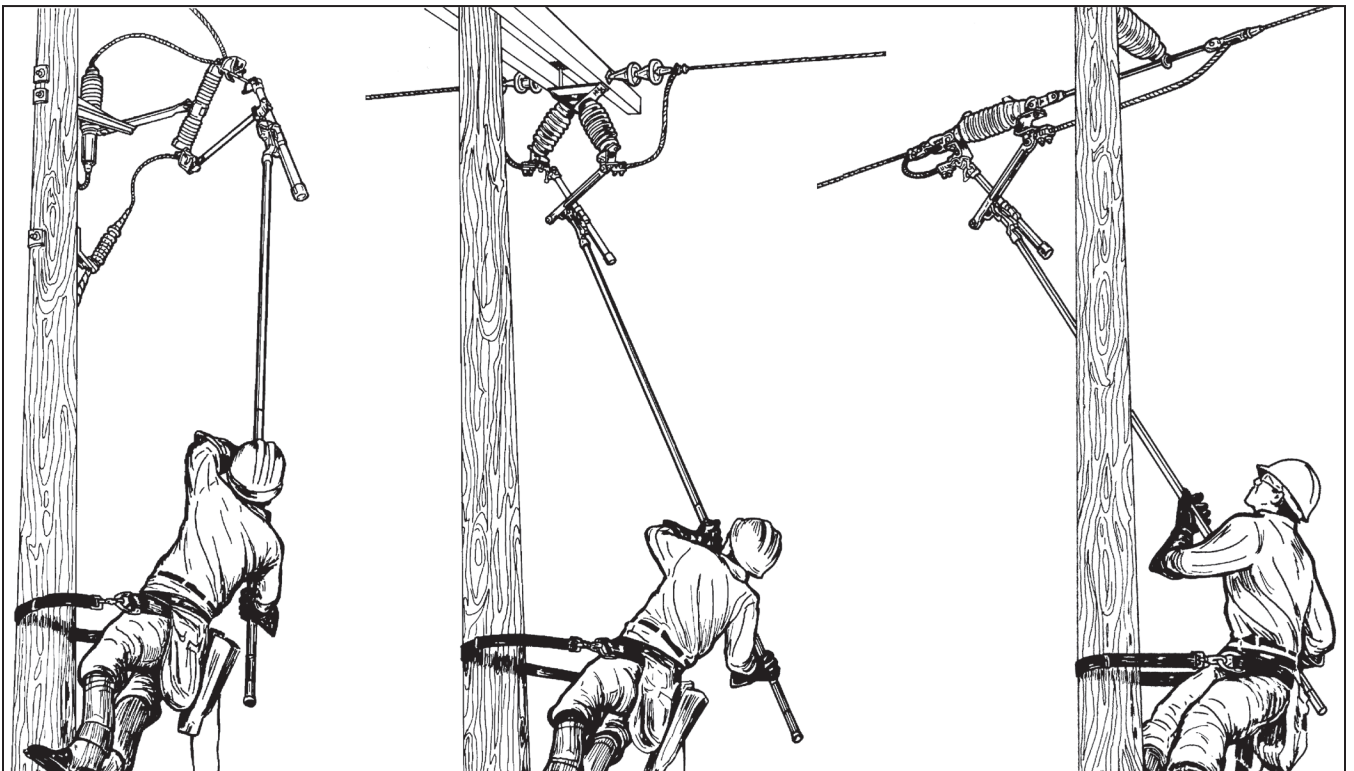

Figure 3. Recommended pole positions for an operator using the Loadbuster tool with overhead distribution devices.

Overhead Distribution Devices

Check for proper resetting of the Loadbuster tool by extending the tool about 3 inches (76 mm) by hand. Throughout this travel, an increasing spring resistance should be felt.

NOTICE

Although the text and figures that follow describe the operation of the Loadbuster tool with SMD-20 Power Fuses, the procedure is equally applicable to fuse cutouts, disconnects, power fuses, and fuse limiters.

Complete the following steps when using a Loadbuster tool with overhead distribution devices:

STEP 1. Reach across in front of the power fuse with the Loadbuster tool and hook the anchor, which is located at the top of Loadbuster tool

over the attachment hook on the far side of the power fuse. See Figure 4.

STEP 2. Swing the Loadbuster tool toward the power fuse and pass the Loadbuster tool pull-ring hook through the pull-ring on the power fuse. The pull-ring latch will deflect and, upon complete entry of the pull-ring, will spring back, locking the Loadbuster tool to the pull-ring. The Loadbuster tool is now connected across the upper contact of the power fuse. See Figure 4.

STEP 3. *To open the circuit:* Operate the Loadbuster tool with a firm, steady pull until it is extended to its maximum length. See Figure 5 on page 13. Avoid jerking and hesitating. The resetting latch will keep it open.

Generally, there will be no indication of circuit interruption but minor arcing may be noted at the pull-ring hook and at the anchor,

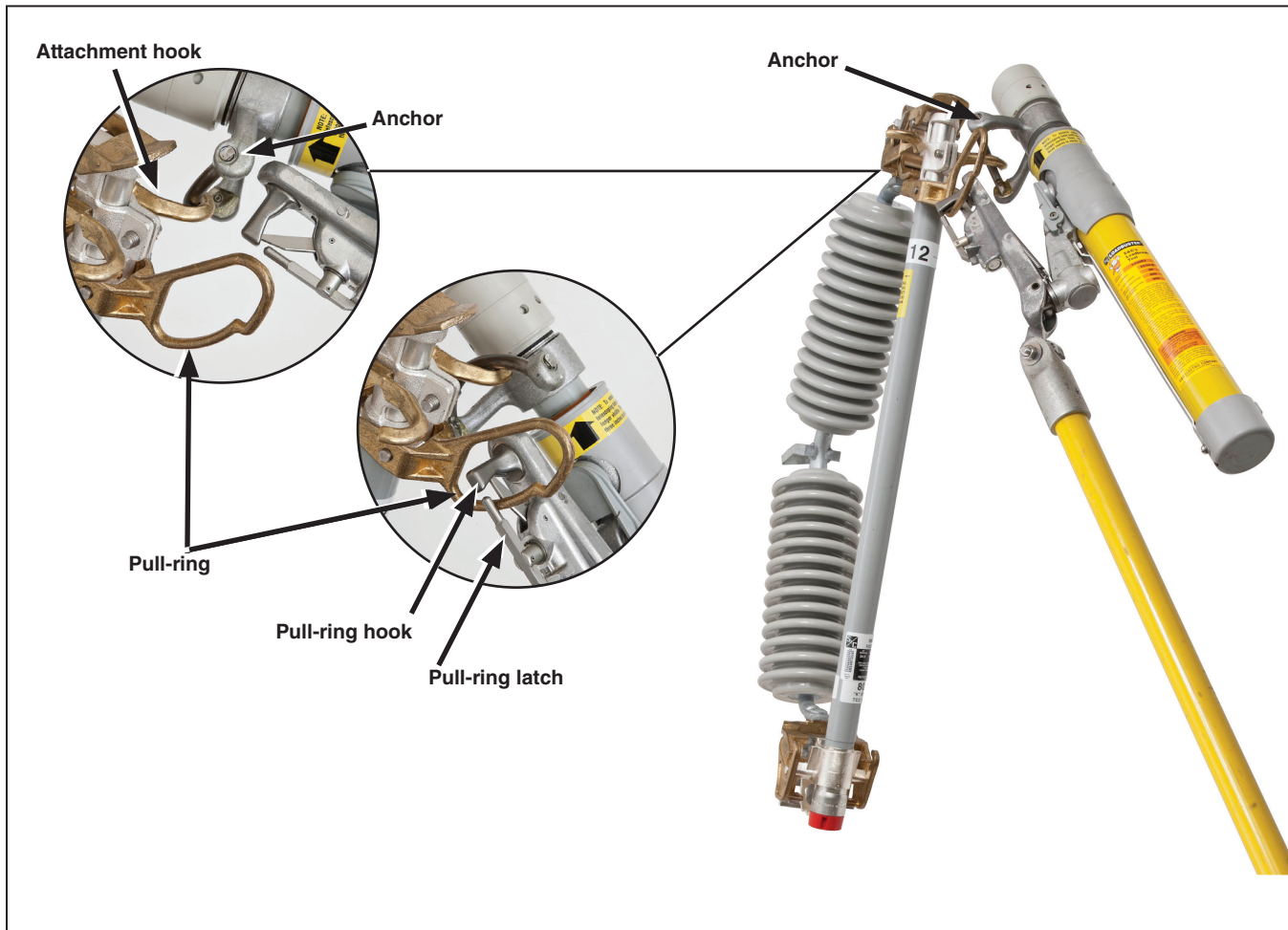

Figure 4. The Loadbuster tool connected to a Type SMD-20 Power Fuse, outdoor distribution.

particularly when interrupting load currents approach the rating of the tool. The only sound will be that of the Loadbuster tool tripping.

STEP 4. *To detach the Loadbuster tool after circuit interruption:* First, raise it slightly and disengage the anchor from the attachment hook.

⚠ CAUTION

When the Loadbuster tool is raised, the open gap distance is reduced. **Careless manipulation could decrease the open gap to the point where flashover can occur, causing minor injury.**

Next, bring the power fuse toward its fully **Open** position, as illustrated in Figure 6. (S&C recommends this procedure as uniform practice because disconnects will not necessarily open fully from gravity.)

Remove the Loadbuster tool from the pulling by turning the pole. This will deflect the pull-ring latch to release the pull-ring.

On fuse cutouts, fuse limiters, or power fuses on which the fuse tube or power fuse will drop fully open by gravity, it may be preferred to remove the Loadbuster tool by “rolling” it off both the attachment hook and pull-ring at the same time merely by twisting the pole after the Loadbuster tool has been tripped and fully extended.

To perform this operation easily and smoothly, always roll the Loadbuster tool so it rotates in an upward direction.



Figure 5. The Loadbuster tool in the Tripped position.

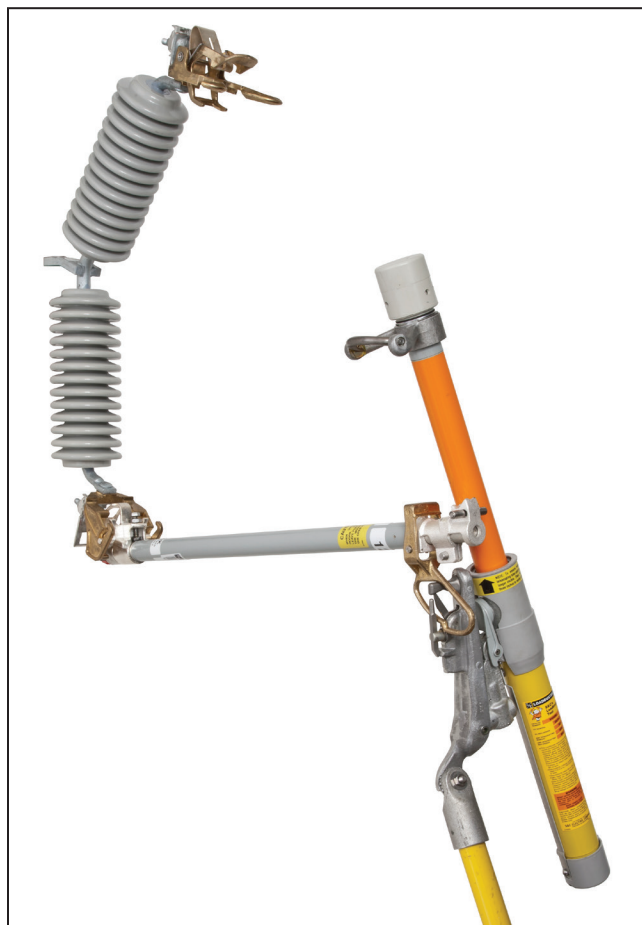

Figure 6. Detaching the Loadbuster tool from a power fuse.

Operation

STEP 5. To reset the Loadbuster tool for the next operation, hold as shown in Figure 7. Extend the tool slightly and lift the resetting latch with the thumb. With the latch up, press down on the inner tube assembly until the tool is closed completely so the trigger can reset itself. When reset properly, the orange paint on the inner tube assembly will no longer be visible.

Check for proper resetting by extending the tool about 3 inches (76 mm). Throughout this travel an increasing spring resistance should be felt.

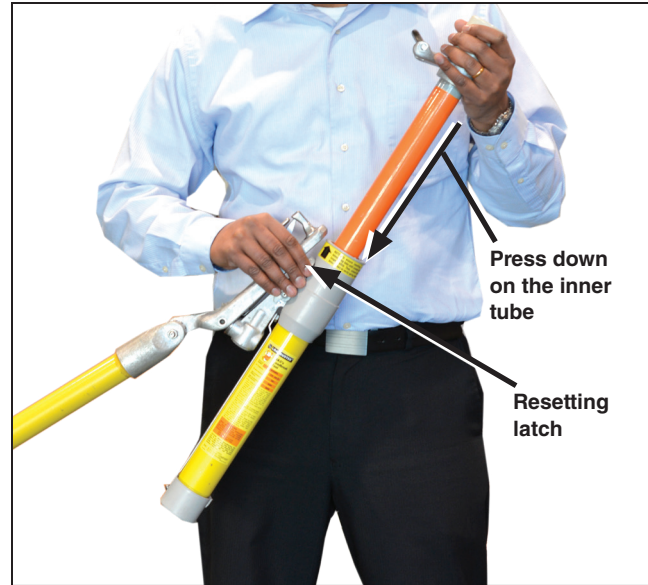

Figure 7. Resetting the Loadbuster tool.

Pad-Mounted Gear

Loadbuster—The S&C Loadbreak Tool (catalog number 5300R3-E) makes an interrupter switch out of every power fuse or disconnect switch in pad-mounted gear suitably equipped with the attachment hook. Operation in pad-mounted gear is similar to that of overhead distribution devices in most respects.

⚠ CAUTION

To avoid partial opening or flashover, which can cause minor injury, Loadbuster tool catalog number 5400R3, rated 25/34.5 kV, must not be used with metal enclosed switchgear, metal-enclosed fuses, or pad-mounted gear. There is not enough clearance to use that tool model on these devices.

Before using the Loadbuster tool in pad-mounted gear, review the “Clearance Requirements for Use in Pad-Mounted Gear” section on page 8. Also, review information presented in the “Overhead Distribution Devices” section starting on page 12.

When using the Loadbuster tool in pad-mounted gear, avoid any tendency to grasp the pole close to the Loadbuster tool end. Be sure instead to grasp the pole near the end opposite the Loadbuster tool.

The following text and figures describe the operation of the Loadbuster tool (catalog number 5300R3-E) with power fuses in pad-mounted gear, but the procedure is equally applicable to that used with disconnect switches in pad-mounted gear:

- STEP 1.** Reach across in front of the fuse unit or holder with the Loadbuster tool and hook the anchor, located at top of the Loadbuster tool, over the attachment hook on the far side of the fuse unit or holder. See Figure 8. Only one attachment hook is provided.
- STEP 2.** Swing the Loadbuster tool toward the fuse unit or holder and pass the Loadbuster tool pull-ring hook through the pull-ring of the fuse unit or holder. The pull-ring latch will deflect and, upon complete entry of the pull-ring hook, will spring back, locking the Loadbuster tool to the pull-ring. The Loadbuster tool is now connected across the upper contact of the power fuse. See Figure 9.

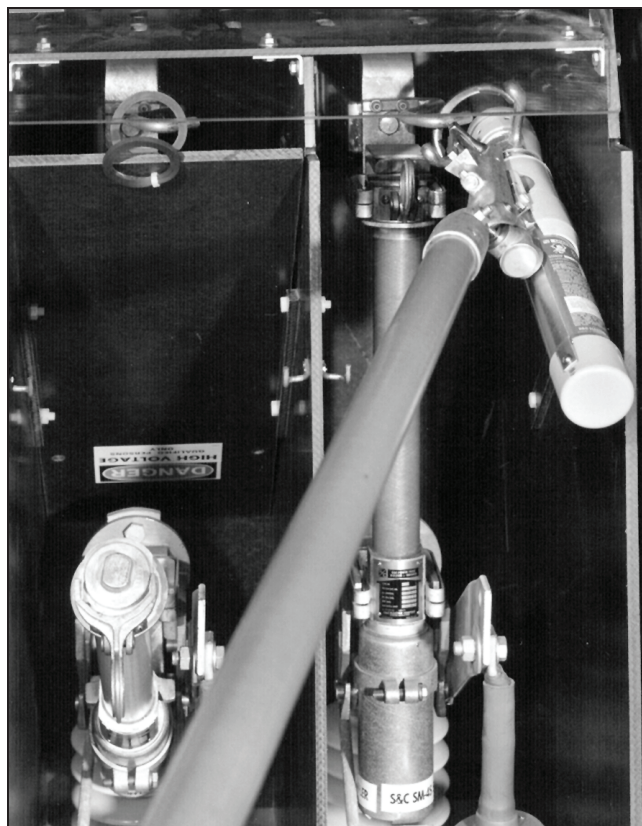

Figure 8. The Loadbuster tool’s anchor connected to an attachment hook.

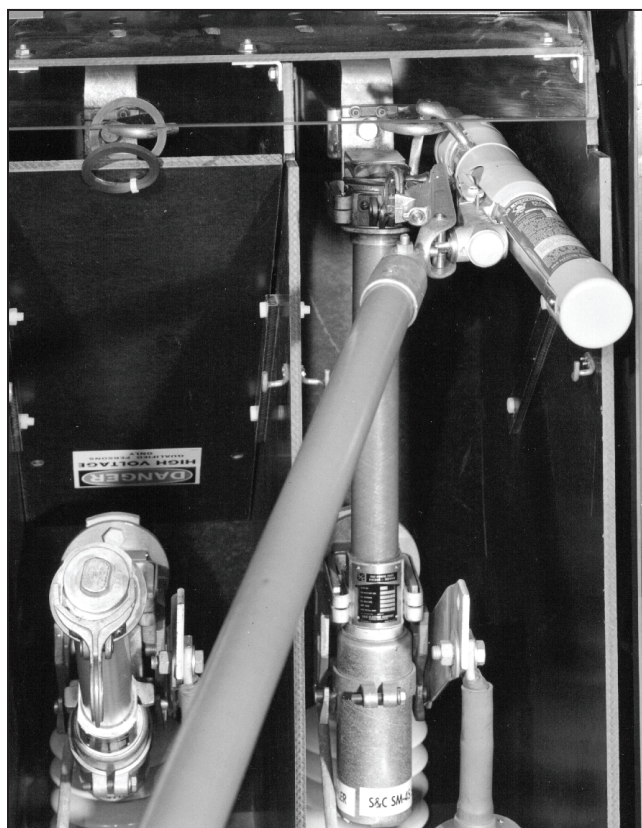

Figure 9. The Loadbuster tool connected to a power fuse.

Operation

- STEP 3. *To open the circuit:*** Operate the Loadbuster tool with a firm, steady pull until it is extended to its maximum length. See Figure 10. Avoid jerking and hesitation. The resetting latch will keep it open. Commutation arcing may be noted at the pull-ring hook and at the anchor, but the only sound will be that of the Loadbuster tool tripping.
- STEP 4. *To detach the Loadbuster tool after circuit interruption:*** Roll the tool upward by turning the pole. See Figure 11. This will deflect the pull-ring latch to release the pull-ring hook from the pull-ring of the fuse unit or holder. Disengage the anchor from the attachment hook and withdraw the tool.
- STEP 5. *To reset the Loadbuster tool for the next operation:*** Hold as shown in Figure 7 on page 14. Extend the tool slightly and lift the resetting latch with the thumb. With the latch up, press down on the inner tube assembly until the tool is closed completely so the trigger can reset itself.

When reset properly, the orange paint on the inner tube assembly will no longer be visible. Check for proper resetting by extending the tool about 3 inches (76 mm). Throughout this travel, an increasing spring resistance should be felt.



Figure 10. The Loadbuster tool in a Tripped position.

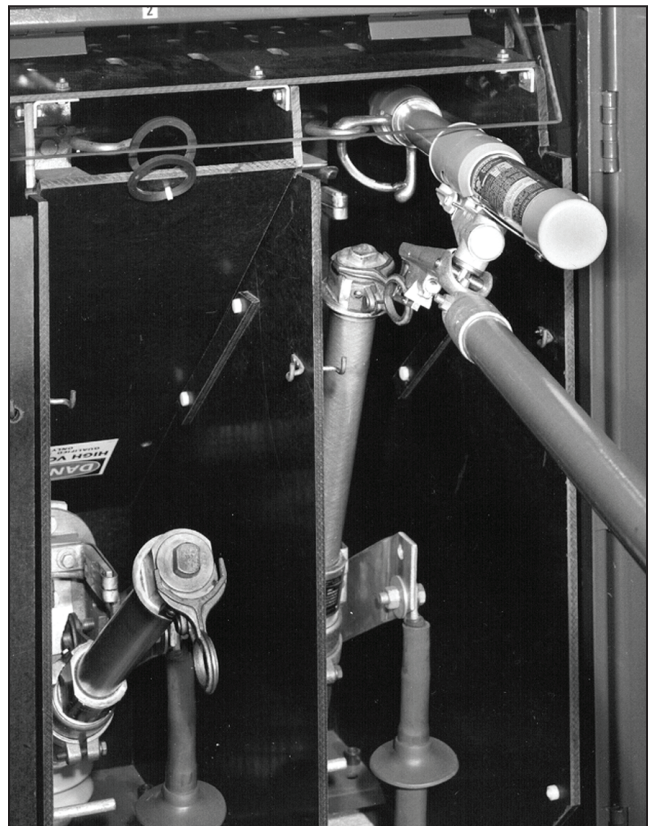

Figure 11. Detaching the Loadbuster tool from a power fuse.

Understanding the Operation Counter

Loadbuster tools manufactured after March 2003 are equipped with a nonresettable **Operation** counter feature for monitoring the use of tools to make more informed inspection and maintenance decisions.

The **Operation** counter is built into the Loadbuster tool's silencer and can be easily added to existing tools. See Figure 12.



Figure 12. The Loadbuster tool's Operation counter.