

TABLE OF CONTENTS

	Page
FOREWORD	1
Illustration	2
INSTALLATION	
Pole Mounting	3
Brake Adjustment	3
Threading	4
Reel Mounting	4
Controller Positioning	4 & 5
Unit Use	5
PARTS REPLACEMENT	
Parts Illustration:	
Parts List	7 & 8

FOREWORD

The Original Pilot Line Controller System designed by Alaskaug for stringing pulling lines for overhead distribution. It consists of a positive braking controller and a storage reel for rope which mounts on the lead pole at any desired height.

Once the controllers and storage reels are mounted on the lead pole, the lineman takes the pilot lines up with him and lays them in the stringing blocks as he frames each pole. After these lines are pulled out, they can be tied off under tension and left until time for stringing the conductor.

When the pulling line is ready to be installed, the same storage reel can be mounted on either a pole mounted winch or a line truck winch.

Adapters are available for this purpose
This allows the storage reel to re-wind the pilot line, thus hauling in the pulling line under tension.

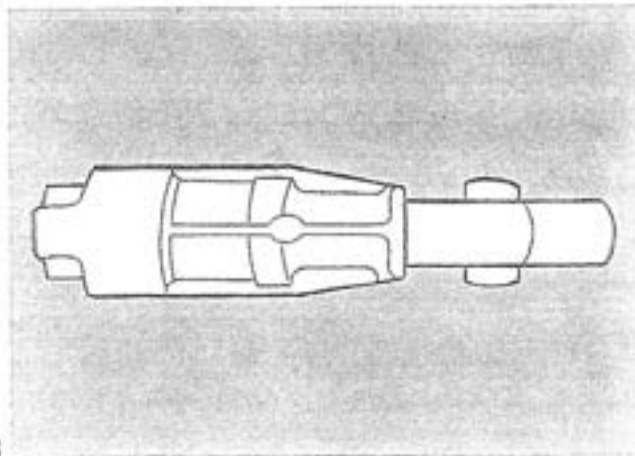
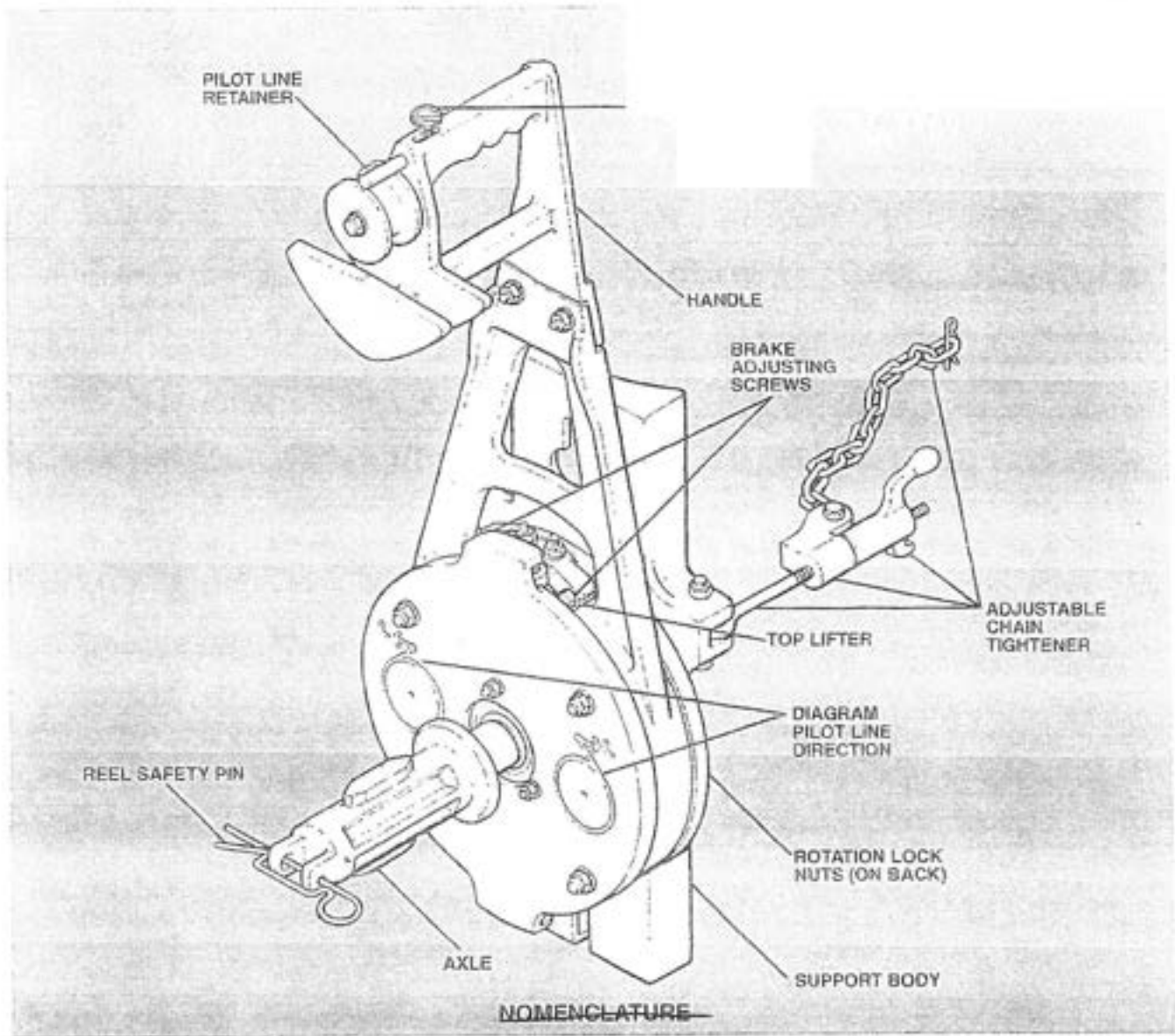

AI-75 WA
Winch Adapter

"Pilot Line Controller"

Installation

Model **AT-75C** and **AT-85C** controllers can be mounted on wooden poles with lag screws or mounted on non-wooden poles with the adjustable chain tightener.

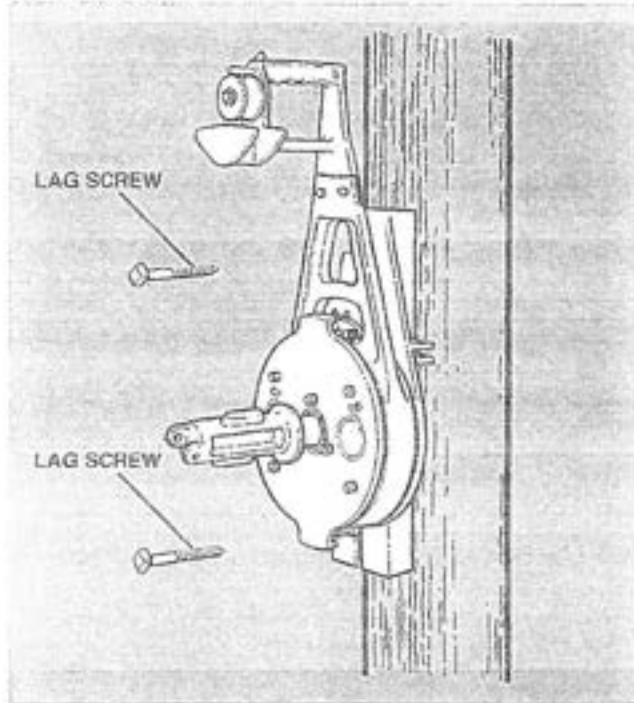

It can also be mounted on wooden or metal poles with adjustable chain tightener, included with each unit.

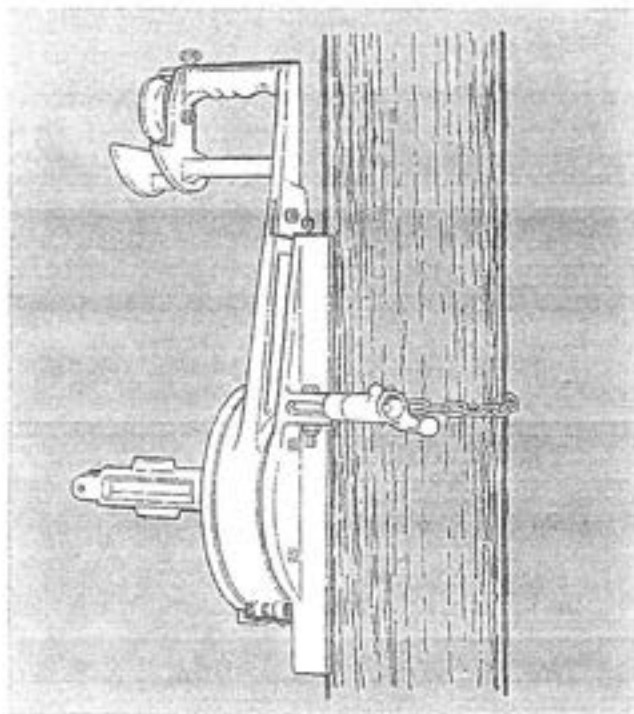

The brake on the controller allows the storage reel to dissipate the pilot line when the rope is pulled and engages when the rope is slack. This eliminates "backwinding" while holding tension during the installation of the pilot line.

The brakes on the controller are factory set. If necessary to adjust breaks, tighten or loosen adjustment screws on the lifter located on the front controller at the top and bottom as shown.

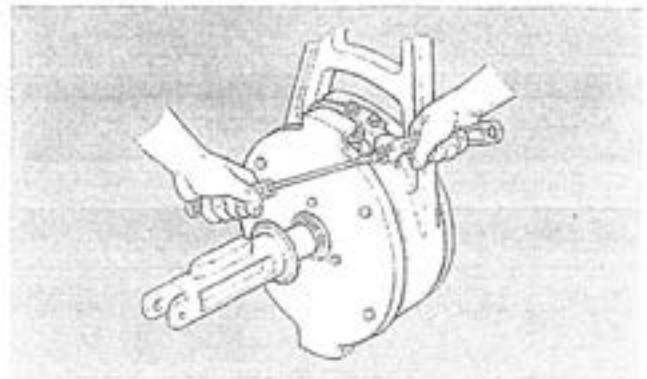

BRAKE ADJUSTMENT

To create more tension on the breaks it is necessary to adjust the screws counter-clockwise. Example: Top lifter-right screw, bottom lifter-left screw. Note that the nuts on the lifters must be loosened and tightened before and after adjustments.

The locking nuts on the top and bottom lifters must be loosed before and retightened after making adjustments. Cover plate locking nuts must be secure. They may require minimal tightening for proper operation.

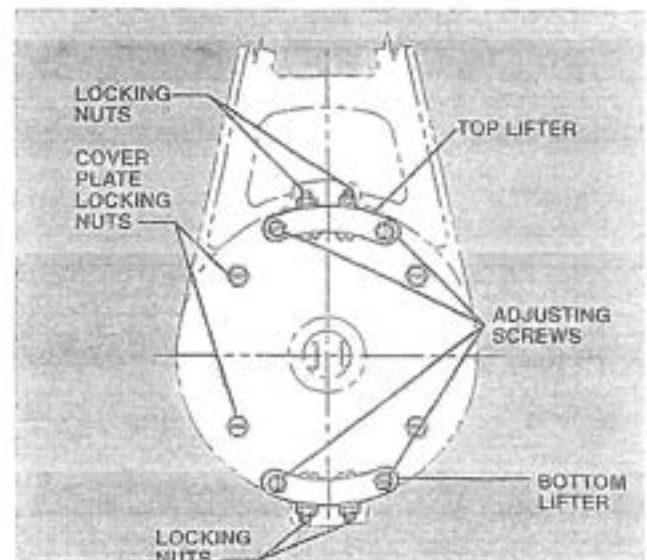

“Pilot Line Controller”

4. Before installation of the storage reel to the controller be sure to check the pilot line diagram on the face plate because the pilot line can be threaded in either direction of the pull.

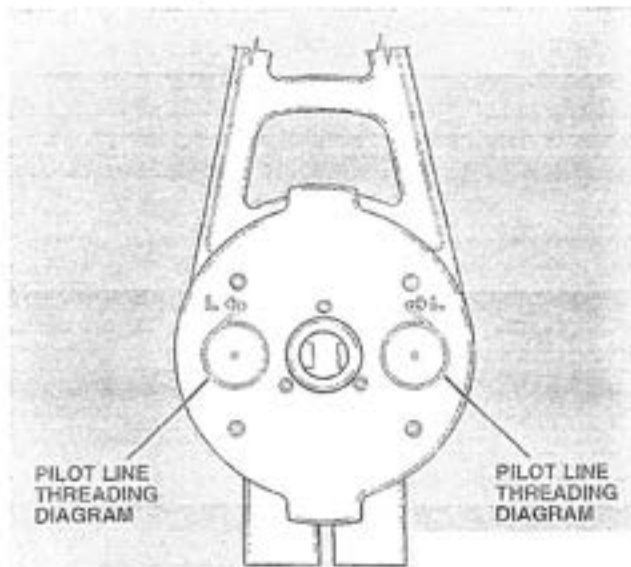

Once the controller is securely mounted to the pole, model **AT-75SR** and **AT-85SR** storage reels can be mounted on the controller according to the amount of reel compatible with the series controller. Once secured into position the safety pin can be inserted to ensure the reel is in place.

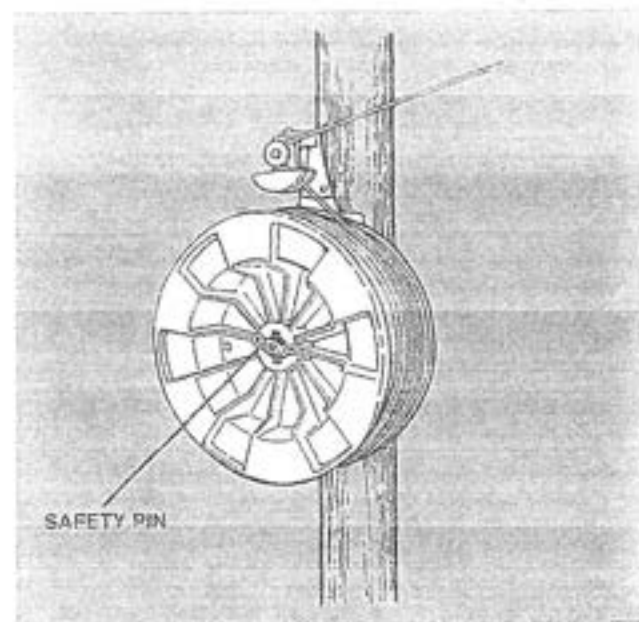

Ensuring correct threading of the pilot line to pay out or to pull in the opposite direction reverse the reel and threading procedure. This would apply when the pilot line is to be threaded first to the block on the next pole.

If the pilot line is to feed to the same block on the same pole that the controller is mounted follow these steps:

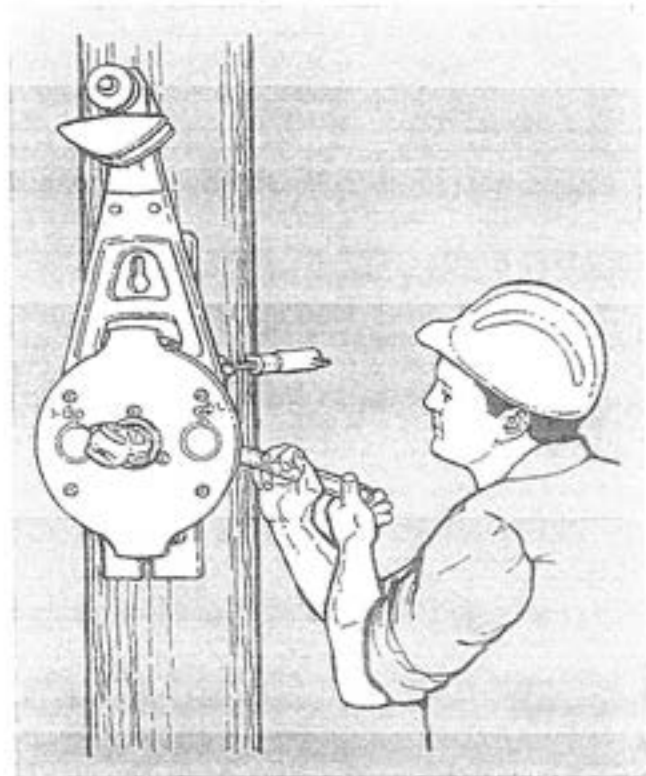

1. With a wrench loosen the nuts located on both sides of the controller (all to be done with the controller still attached to the pole)

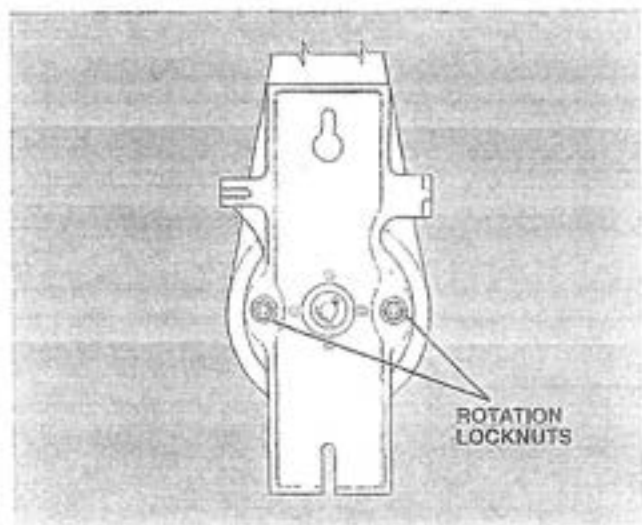

6.

INSTALLING "THE SPIDER II SYSTEM"

Position the controller arm at any angle up to 90 degrees at any direction, once in desired position, re tighten the nuts.

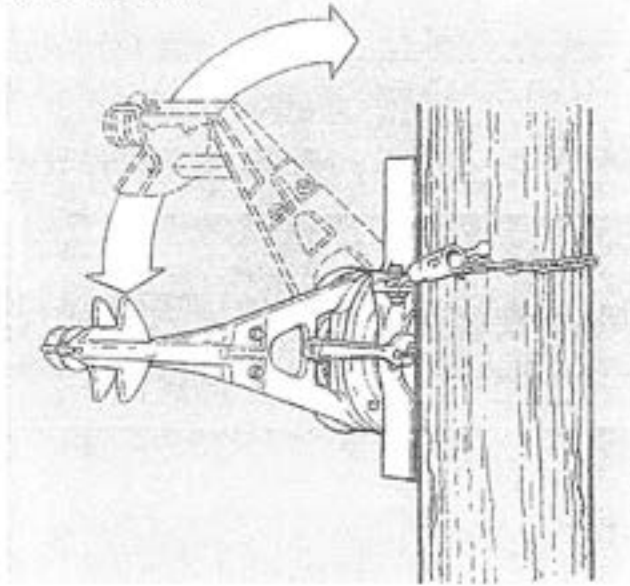

All storage reels are designed specifically for 5/16" 12 strand Polyester rope ONLY. The maximum line tension is 500lbs based on the recommended work load of the rope. The rope is available in four different colors: yellow, blue, green and red. The rope is non-twisting, high UV resistance and high abrasion resistance.

Once the pilot lines have been installed, they can be connected one at a time to the pulling line. The pulling line is then pulled under tension.

Position the reel on the controller and thread as usual.

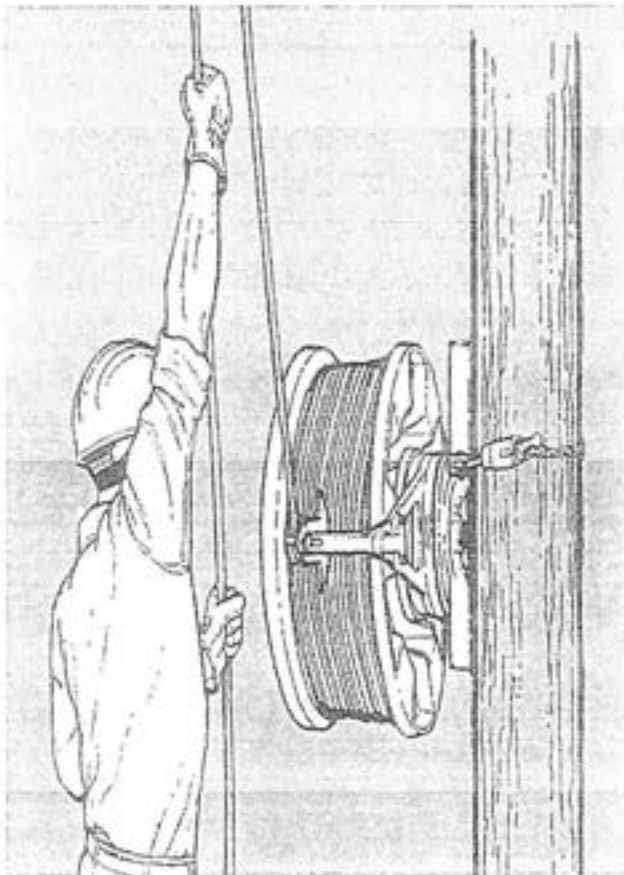

The Pilot Line Controllers can be mounted singularly or any desired number on the pole for maximum efficiency.

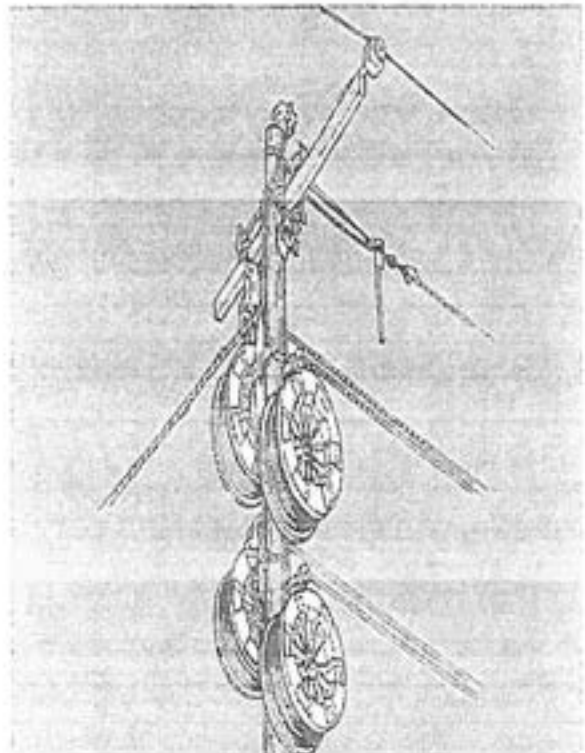

Pilot Line Controller Illustration

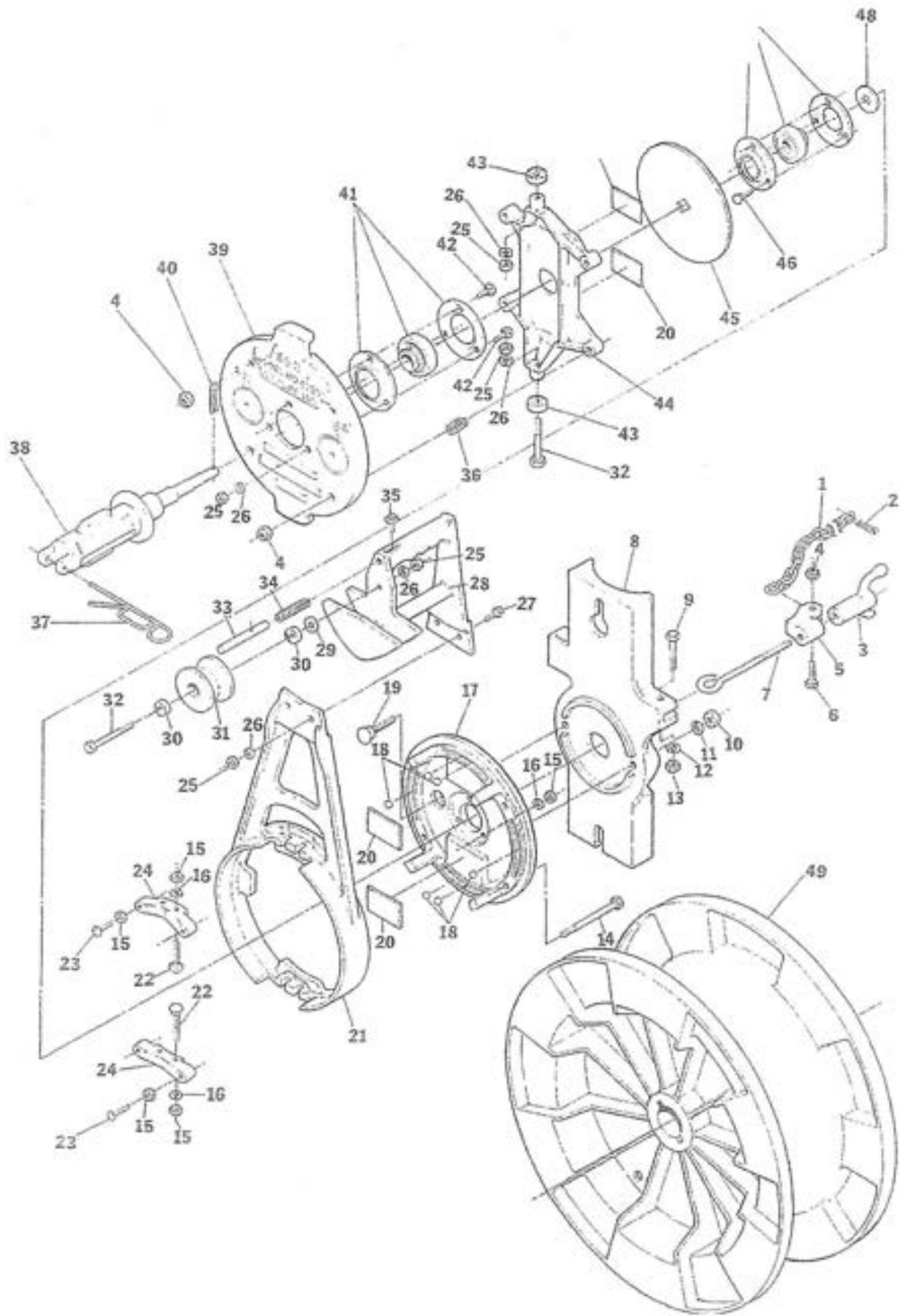

Pilot Line Controller PARTS LIST

NO.	DESCRIPTION	QTY.	NO. REQ.
1	CHAIN	7536	1
2	CHAIN CLIP	7537	1
3	CRANK	7513	1
4	NUT-LOCK	7583	5
5	CHAIN TERMINAL	7511	1
6	BOLT	7582	1
7	EYEBOLT	7535	1
8	SUPPORT BODY	7505	1
9	BOLT	7529	1
10	NUT	7589	2
11	LOCKWASHER	7588	2
12	LOCKWASHER	7534	1
13	NUT	7533	1
14	BOLT	7526	4
15	NUT	7557	7
16	LOCKWASHER	7558	7
17	TURNTABLE	7506	1
18	BALL BEARING	7553	6
19	BOLT	7592	2
20	BRAKE PAD	7525	4
	RESIN FOR BRAKE PADS	7525-A	1
	CATALYST FOR RESIN	7525-B	1
21	PIVOT ARM	7503	1
22	CARRIAGE BOLT	7521	4
23	BOLT	7532	4

(CONTINUED ON NEXT PAGE)

Pilot Line Controller PARTS LIST

NO.	DESCRIPTION	Part #	NO. REQ.
24	UFTER	7512C	2
25	NUT	7524	8
26	LOCKWASHER	7528	8
27	BOLT	7522	2
28	HANDLE	7507	1
	HANDLE ASSY. COMPLETE WITH ROLLER	7507C	1
29	WASHER	7581	1
30	BEARING	7587	2
31	ROLLER	7591	1
32	BOLT	7580	3
33	ROPE RETAINER	7530	1
34	SPRING (ROPE RETAINER)	7577	1
35	THUMBSCREW	7531	1
36	SPRING	7579	4
37	SPRING CUP (REEL)	7571	1
38	AXLE	7517	1
39	FRONT COVER PLATE	7501	1
40	COTTER KEY	7539	1
41	BEARING (FRONT COVER)	7551	1
42	BOLT	7523	3
43	BEARING (CLUTCH PLATE)	7559	2
44	CLUTCH PLATE	7509	1
45	DISC	7538	1
46	BOLTS	7556	3
47	BEARING	7555	1
48	WASHER	7540	1
49	REEL Aluminum, AT-75-SR	At-75 SR	1